



# Design and Analysis of Bolted Joints (DABJ)

## Course Book

Last revision: December 2025

Developed and taught by

Thomas P. Sarafin

Instar Engineering and Consulting, Inc.  
tom.sarafin@instarengineering.com

This 24-hour to 32-hour course is offered jointly by

Instar Engineering and Consulting, Inc.  
Highlands Ranch, CO 80126  
(303) 903-9581  
Email: tom.sarafin@instarengineering.com  
www.instarengineering.com

Applied Technology Institute  
349 Berkshire Drive, Riva, Maryland 21140  
Toll Free: (888) 501-2100 • Local: (410) 956-8805  
Email: ati@aticourses.com  
www.aticourses.com

**See next page for copyright notice and restrictions**

# Copyright Notice

The copyright for this material is held by Instar Engineering and Consulting, Inc. (“Instar”).

This file is (or soon will be) available for free download at <https://instarengineering.com/resources.html>.

Permission is granted by Instar for anyone to freely copy, distribute, and print this material, but only in its unaltered form. An individual section may be copied or printed, but only in its entirety, including the first page of that section, which specifies these distribution restrictions, and with headers and footers intact. Unaltered individual figures and tables and portions of text may be copied or used, but only when they show the text in quotes and when accompanied with the following statement:

Source: Design and Analysis of Bolted Joints (DABJ) course book, Thomas P. Sarafin, Instar Engineering and Consulting, Inc. Reproduced with permission.

The date of last revision also should be included in the reference. Direct all questions to ...

Tom Sarafin, President and Chief Engineer  
Instar Engineering and Consulting, Inc.  
tom.sarafin@instarengineering.com

If you want the full experience—with oral explanations, class exercises, background information, relevant stories from the teacher’s experience, and ability to ask questions—you will need to take the course.

# Disclaimer

Our intent is to provide dependable information and recommendations regarding bolted joints, but we cannot guarantee our guidance. The behavior and capability of bolted joints is difficult to predict. Even with the best information available, it is advisable to test joints of new design early in the program at inexpensive levels of assembly.

This course addresses NASA-STD-5020 but is not officially approved by NASA.

# ***DABJ—Design and Analysis of Bolted Joints for Aerospace Engineers (with an emphasis on spacecraft)***

24-hour Course (extended version is 32 hours)

---

- Objectives:
- Help you understand how to design bolted joints that
    - can withstand life-cycle environments and function as required
    - are relatively inexpensive and easy to assemble
    - are trouble-free
  - Share methods and thought processes for analysis
  - Help you understand analysis applications and limitations
  - Help you understand the mechanics of a preloaded joint and how they relate to failure.
  - Help you understand and learn to use NASA-STD-5020B for threaded fastening systems, and provide insight into its development.
  - Provide a valuable reference and a trail to data sources.

Target audience: Structural and mechanical engineers (design and analysis), responsible/cognizant engineers, and others interested in the topic

Permission is granted by Instar for anyone to freely copy, distribute, and print this material, but only in its unaltered form. This section may be separately copied or printed, but only in its entirety, including this page and with headers and footers intact. Unaltered individual figures and tables and portions of text may be copied or used, but only with text in quotes and with the following statement "Source: Design and Analysis of Bolted Joints (DABJ) course book, Thomas P. Sarafin, Instar Engineering and Consulting, Inc. Reproduced with permission." The date of last revision also should be included in the reference. If you have questions, contact [tom.sarafin@instarengineering.com](mailto:tom.sarafin@instarengineering.com).

## **Course Developer and Teacher: Tom Sarafin, Instar Engineering**

- Engineering consultant, structures and mechanical systems
- President and chief engineer of Instar; founded Instar in 1993
- Has consulted for NASA, DARPA, DOD Space Test Program, Lockheed Martin, DigitalGlobe (Maxar), U.S. Air Force Academy, Sierra Nevada Corp (Sierra Space), Planetary Systems Corp (Rocket Lab USA), and many other organizations
- Key member of the team that developed the original (basic release) NASA-STD-5020 for design, analysis, quality assurance, and verification of threaded fastening systems
- At Martin Marietta, Denver, (now Lockheed Martin) from 1979 to 1993 (stress analysis, preliminary structural design, structural test engineering, verification planning; technical lead; and project manager)
- Editor and principal author of the book *Spacecraft Structures and Mechanisms: From Concept to Launch* [1995]. Contributing author to *Space Mission Analysis and Design* (1<sup>st</sup>, 2<sup>nd</sup>, and 3<sup>rd</sup> editions) [1991, 1992, & 1999] and *Human Spaceflight: Mission Analysis and Design* [1999]
- Has taught over 350 short courses (2 to 4 days) to more than 7000 engineers and managers
  - SCS—Spacecraft Structures, from Concept to Launch (formerly SMS—Space Mission Structures)
  - SDA—Structural Design and Analysis for Aerospace Engineers
  - DABJ—Design and Analysis of Bolted Joints for Aerospace Engineers
  - STDI—Structural Test Design and Interpretation
  - VTSS—Vibration Testing of Small Satellites
  - TenP—Ten Principles for Successful Space Programs

## Some Opening Comments

Our first thought: Everyone knows how to use bolts and screws.

- In use for hundreds of years
- Countless fasteners used in all industries

Reality: Almost everyone has problems with threaded fasteners!

- Bolted joints are complex systems, and most people don't understand how they work.
- Processes for design, analysis, and installation vary widely, even within a single organization.

**In the space industry, lack of understanding and lack of care regarding threaded fasteners have led to many millions of dollars in lost missions, lost hardware, and wasted time.**

Adapted from “Fastener Issue Overview Within NASA Manned Space Flight Programs”, a 2/7/07 presentation package by Chris Hansen, who started the NASA-STD-5020 development project and became Chief Engineer for the International Space Station at NASA Johnson Space Center in 2007.

For those new to the space industry:  
**Key Considerations for Bolted Joints in Spacecraft**

- Weight critical (or at least important)
- Wide range of environments and temperatures—ground, launch, space
- Other than material selection, most bolted-joint designs are driven by the severe loading of launch and ground testing for launch environments
  - Much of the load comes from dynamic response, predicted with math models
  - Joints must be stiff to keep natural frequencies high and avoid excessive loading
  - Short duration environment; fatigue not as much of a driver as for many other industries
- Bolts are procured per specifications, most of which were developed for the military aircraft industry
  - High strength, environmentally compatible materials, strict quality control
- Bolts are relatively expensive, and many have long lead times
- Typically very low-volume production
  - Spacecraft assembly and integration in a clean room with hand tools
  - Integration and test can take more than a year for large, one-of-a-kind spacecraft
- Disassembly and reassembly are usually required

## Typical Top-Level Structural Design Criteria for Space and Launch Vehicles (adapted from aircraft industry)

The structure (or joint) shall ...

- be able to withstand **limit loads** (highest expected applied loads)
  - without detrimental deformation
    - such as the structure making contact with something else during launch
    - or a tension joint gapping and significantly losing stiffness, making linear loads analysis less dependable
  - without fatigue failure when accounting for all loading cycles expected over the product’s life cycle
    - Some programs require use of a fatigue analysis factor, similar to a factor of safety, for this assessment; most programs don’t expect fatigue analysis at all.
- have sufficient **yield strength**: be able to withstand **design yield loads** (limit loads multiplied by a yield factor of safety of 1.1 or higher), without detrimental yielding or detrimental permanent deformation
  - Such as yielding or joint slipping that impairs function or performance
- have sufficient **ultimate strength**: be able to withstand **design ultimate loads** (limit loads multiplied by an ultimate factor of safety of at least 1.4 for NASA programs) without catastrophic failure

Typically shown by ...

Analysis with test-verified models

Analysis alone\*

Analysis and test

Analysis alone\*

**Many aerospace structural engineers focus on ultimate strength, but any of the above criteria can drive the design.**

\*Unless testing a sacrificial structure

## Typical Aerospace Design Criteria Matrix for Bolted Joints

Load level	Are any of these failures or conditions permitted?				
	Detrimental elastic deformation	Detrimental permanent deformation	Fatigue failure	Catastrophic failure, such as rupture or collapse	Gapping (separation)
Limit load	No	No	No	No	No (in most cases)
Design yield load	Yes	No	Yes	No	Yes*
Design ultimate load	Yes	Yes*	Yes	No	Yes*

\*Judgment is required to apply these criteria appropriately. Examples:

- If gapping could allow propellant to leak, which in turn could lead to catastrophic failure or a risk to human safety, then such gapping is not permitted at the design ultimate load.
- If yielding or gapping causes a reduction in stiffness, which in turn causes loads to redistribute, leading to potential catastrophic failure elsewhere in the structure, then such yielding or gapping is not permitted at the design ultimate load.

When limit loads for design are derived by linear loads analysis, that analysis is expected to apply only up to limit load. Nonlinearities that significantly affect accuracy of such loads analysis are acceptable above limit load. But we need to assess the effects of nonlinear load distribution at the applicable load level when assessing the above criteria.

## In This Course, I Will Attempt to Debunk Some Myths

You need a PhD to do proper analysis of bolts and joints.

Either that, or you need to have the most knowledgeable stress analyst (preferably a PhD) in your organization develop a complicated spreadsheet so that everyone else can do bolt and joint analyses.

To assess ultimate strength for a bolt in a joint under applied tensile load, you need to calculate the total load in the bolt, equal to preload plus some percentage of applied load.

 **Myth. For most well-designed joints, analysis is relatively simple, usually based on math and physics we learned in high school. Much of the detailed analysis that has become commonplace—including assessment of von Mises stress calculated with FEA—is based on linear theory that does not hold up in the test lab.**

 **Myth. A preloaded, well-designed, all-metallic joint will gap under applied tensile load before the bolt breaks, so preload has no effect on ultimate strength for such a joint.**

## Myths Related to Yielding

To determine how applied loads distribute between bolts, you must use finite element analysis, with each bolt modeled discretely.

You need to make sure the tensile stress in the bolt's cross section never exceeds the material's yield strength, either while torquing or when under the design yield load.

You also can't allow the stresses in the joint members (attached parts) to exceed the materials' yield strength at the design yield load.



**Myth. By taking advantage of ductility in the design of all-metallic joints, we can ensure loads will distribute more evenly between bolts before rupture occurs than is predicted with linear-elastic FEA.**



**Myth. For most joints, bolt yielding in tension is not detrimental. Localized yielding in joint members is often not detrimental, either.**

**On the other hand, for alignment-critical assemblies there can be detrimental permanent deformation in joints even when stresses are below the materials' yield strengths.**

## Myths Related to Preload

Our design criteria don't allow us to count on friction to help carry shear loads in a joint, so there's no reason for a high preload in a shear joint. A low preload is actually better for a shear joint because preload reduces bolt strength as a result of interaction of tension (preload) and shear acting on the bolt.

A bolt in a joint under cyclic applied tensile load will have longer fatigue life if it has a low preload rather than a high preload, as long as the joint doesn't gap under applied load. This is because stress will cycle about a lower mean stress.



**Myth. With bolts in clearance holes, we want high preload so that shear is carried by friction rather than causing the joint to slip, especially if slip is cyclic. Only when assessing ultimate strength must we show the bolts can carry the design shear load without the benefit of friction. Preload neither increases nor decreases ultimate strength of most shear joints.**



**Myth. Linear analysis may show this to be the case, but the opposite is true: A higher preload typically leads to longer fatigue life.**

## The Key is a Good Design

- Don't tell me you're just an analyst and have no input to the design.
- And don't tell me you're just a design engineer, with no involvement in analysis.
- Even if your company or organization has given you one of these titles, you need to think like a mechanical systems engineer and work as a team if you want to develop joints that are dependable, efficient, and cost effective.
- A good design ...
  - provides direct load paths
  - takes advantage of ductility
  - matches hardware appropriately
  - ensures high preload
  - provides access for assembly and disassembly with standard tools
  - requires attention to detail

**A good design is predictable and easy to assess.**

**A good design is guided by analysis. It's inefficient to wait until the design is complete before starting the analysis.**

## DABJ History

- I developed the first version in 1998 at the request of NASA Goddard
  - Titled “Design and Analysis of Fastened Joints” (DAFJ); 8-hour course, taught twice in 1998
- Expanded into a 2-day course in 1999—Taught 21 times in this format; course materials revised (improved) after nearly each class
- Revised into a 3-day course in 2005 at NASA JSC request to include a section on compliance with NSTS 08307 (Ref. 7). The course was renamed “Design and Analysis of Bolted Joints” (DABJ)
  - Led to several meetings at JSC, with all concluding that NSTS 08307 should be revised or replaced
    - Helped fuel the NASA-STD-5020 project (new standard for threaded fastening systems), which started in 2007. I served as one of the key team members for this project.
  - Taught 19 times in this format, with periodic revision to capture additional information
- Major revision in June 2010 to include a section on analysis criteria per the draft NASA-STD-5020, which was being developed at that time—taught 10 times between June 2010 and March 2012
- Revised in April 2012 to be consistent with the final version of NASA-STD-5020, which was released in March 2012—taught 40 times, with gradual improvement in content over time
- Revised in March 2019 to address NASA-STD-5020A (Rev A, released in September 2018)—taught 18 times through December 2021
- Made minor changes in January 2022 to address NASA-STD-5020B, released in August 2021—taught 19 times through June 2025
- Along the way, there have been many other improvements not noted above.

**Since 1998, I’ve taught this course, in its evolving versions, well over 100 times to more than 2000 engineers.**

## Contents

### Introduction

1. Overview
2. Screw Threads: Evolution and Important Characteristics
3. Developing a Concept for the Joint
4. Calculating Bolt Loads (applied loads acting on a bolt)
5. Failure Modes and Assessment Methods
6. Thread Stripping and Pull-out Strength
7. Selecting Hardware and Detailing the Design
8. Mechanics of a Preloaded Joint Under Applied Tension
9. Fastening System Analysis per NASA-STD-5020B

Appendix A: Finite Element Modeling of Bolted Joints

Appendix B: Design Tables for Preliminary Bolt Sizing

} Not  
covered  
in class

### Summary

## Detailed Contents

### 1. Overview

- Common problems with bolted joints
- Designing a bolted joint
- Common required characteristics for structures
- General design guidelines for bolted joints
- The importance of preload
- Introduction to NASA-STD-5020
- Key definitions
- High-level Requirements from NASA-STD-5020B
- Margin of safety
- Fastening System Control Plan
- Establishing internal standards and criteria

### 2. Screw Threads: Evolution and Important Characteristics

- History of screw threads
- Rolled vs. cut threads
- Thread-form features and compatibility
- Tensile stress area
- Fine threads vs. coarse threads

## Detailed Contents, continued

3. Developing a Concept for the Joint
  - General types of joints and fasteners
  - Configuring the joint
  - Designing a stiff joint
  - Shear clips and tension clips
  - Avoiding problems with fixed fasteners
  
4. Calculating Bolt Loads (applied loads acting on a bolt)
  - Important cautions
  - How a preloaded joint carries load
  - Temporarily ignoring preload
  - What about friction as a load path?
  - Common assumptions and their limitations
  - A process for calculating bolt loads in a compact joint
  - Example
  - Appendix: More examples of calculating bolt loads

## Detailed Contents, continued

5. Failure Modes and Assessment Methods
  - Understanding stress analysis
  - An effective process for strength analysis
  - Bolt tension and shear
  - Tension joints
  - Shear joints
  - Identifying potential failure modes
  - Bolted shear joints with composite materials
  
6. Thread Stripping and Pull-out Strength
  - How threads fail
  - Computing thread shear areas based on geometry
  - Reducing calculated shear areas by a knockdown factor
  - Results of pull-out testing: #10 fastener installed in a tapped hole
  - Test results with Heli-Coils®
  - Appendix: Comparison of methods for assessing pull-out strength

## Detailed Contents, continued

7. Selecting Hardware and Detailing the Design
  - Selecting compatible materials
  - Selecting the nut: ensuring strength compatibility
  - Threaded inserts
  - Use of washers
  - Bolt features and geometry
  - Selecting fastener length and grip
  - Guidelines for simplifying assembly
  - Establishing preload
  - Torque-preload relationship
  - Locking features and associated NASA-STD-5020B requirements
  - Maintaining preload with prevailing-torque locking features
  - Appendix: Miscellaneous design data and information

## Detailed Contents, continued

8. Mechanics of a Preloaded Joint Under Applied Tension
  - How bolt load changes with applied load
  - Designing to reduce cyclic load in the bolt
  - Estimating bolt stiffness and clamp stiffness
  - Understanding the load-introduction factor
  - Worst case for steel bolts and aluminum fittings
  - Key conclusions regarding load sharing
  - Effects of bolt ductility
  - How temperature change affects preload
  - Appendix: analysis for Example Problem 8-c

## Detailed Contents, continued

9. Fastening System Analysis per NASA-STD-5020B
  - Objectives and summary
  - Nominal, maximum, and minimum preloads
  - Tensile loading: ultimate-strength analysis
  - Separation analysis
  - Tensile loading: yield-strength analysis
  - Shear loading: ultimate-strength analysis
  - Interaction of tension, shear, and bending
  - Joint-slip analysis
  - Fatigue
  - Appendix 9A.1: Additional requirements pertaining to preload calculation
  - Appendix 9A.2: Accounting for bolt bending in a shimmed single-shear joint
  - Appendix 9A.3: Justification for low likelihood of fatigue failure

Appendix A. Finite element modeling of bolted joints with Nastran

Appendix B. Design tables: preliminary bolt sizing based on NASA-STD-5020B analysis criteria

Summary

## Equation Numbering in This Course Book

Not all equations are numbered; only those that are referenced (or potentially referenced in the future) or that appear in NASA-STD-5020B.

An equation number that is simply a number is the number that appears in 5020B.

An equation number that has two parts, separated by a period, is an equation that appears only in this course book, with the first number being the section in which the equation first appears.

Examples:

$$A = b(c + d) \quad (\text{Eq. 87}) \quad \leftarrow \text{Refers to Eq. 87 in 5020B}$$

$$b = \frac{A}{c + d} \quad (\text{Eq. 9.72}) \quad \leftarrow \text{Unique equation number for this course (used when there is no identical equation in 5020B)}$$

Note: Not all 5020B equations appear in this course.

## References

1. Bruhn, E. F. 1973. *Analysis and Design of Flight Vehicle Structures*. Indianapolis, IN: S. R. Jacobs & Associates, Inc. (available at [www.jacobspublishing.net](http://www.jacobspublishing.net))
- 2a. MIL-HDBK-5H. 1998. *Metallic Materials and Elements for Aerospace Vehicle Structures*. Philadelphia, PA: Naval Publications and Forms Center.
- 2b. MMPDS-08. 2013. *Metallic Materials Properties Development and Standardization (MMPDS)*. National Technical Information Service. (replaced MIL-HDBK-5)
3. NASA Technical Memorandum NASA TM X-73305. August 1975. *Astronautic Structures Manual*. (Out of print but available in pdf format through search at <https://ntrs.nasa.gov/search.jsp>)
4. Shigley, Joseph E. and Charles R. Mischke. 1989. *Mechanical Engineering Design*, 5th ed. McGraw-Hill.
5. SAE AS8879, Rev. D. 2004. "Screw Threads—UNJ Profile, Inch." SAE International.
6. ANSI/ASME Y14.6. 2001. "Screw Thread Representation." The American Society of Mechanical Engineers.
7. NSTS 08307, Rev. A. 1998. "Criteria for Preloaded Bolts." Johnson Space Center. (available at <http://euler9.tripod.com/fasteners/index.html>)
8. ASME B1.1. 2003. "Unified Inch Screw Threads (UN and UNR Thread Form)." The American Society of Mechanical Engineers.
9. ASME B18.3. 2003. "Socket Cap, Shoulder, and Set Screws, Hex and Spline Keys (Inch Series)." The American Society of Mechanical Engineers.

continued

## References (continued)

10. NASA-STD-8739.14. “NASA Fastener Procurement, Receiving Inspection, and Storage Practices for NASA Mission Hardware.” June 2, 2020.
11. NASA-STD-8739.1B. “Workmanship Standard for Polymeric Application on Electronic Assemblies.” June 30, 2016.
12. Steeve, B. E. NASA/TM-20205000526. “Aerospace Threaded Fastener Strength with Joint Shims.” April 2020. (Test performed in 2018; see Ref. 13)
13. Bush, Richard. “Bolt Shear-Bending Test Work Order #2018-0576 Sequence 1.” November 8, 2018. (Lab report for the Rev. 12 test)
14. Haviland, Girard S. “Designing with Threaded Fasteners.” *Mechanical Engineering*. October 1983.
15. FF-S-86F. January 7, 2020. “Federal Specification, Screw, Cap, Socket-Head.”
16. Sarafin, Thomas P., ed. 1995. *Spacecraft Structures and Mechanisms: From Concept to Launch* (SSAM). Torrance, CA: Microcosm, Inc., and Dordrecht, The Netherlands: Kluwer Academic Publishers. (Available from the publisher at [astrobooks.com](http://astrobooks.com))
17. Niu, Michael C. Y. 1997. *Airframe Stress Analysis and Sizing*. Hong Kong: Conmilit Press Ltd
18. Niu, Michael C. Y. 1988. *Airframe Structural Design*. Hong Kong: Conmilit Press Ltd
19. Niu, Michael C. Y. 1992. *Composite Airframe Structures*. Hong Kong: Conmilit Press Ltd
20. Barrett, Richard T. 1990. “Fastener Design Manual.” NASA Reference Publication 1228.
21. Hess, D.P. “Comparison of Secondary Locking Features for Threaded Inserts.” July 2007. (unpublished report)

continued

## References (continued)

22. Trego, Linda. November, 1991. "Fasteners for Aerospace Structures." *Aerospace Engineering*.
23. McCombs, William F. 1998. "A Supplement to *Analysis & Design of Flight Vehicle Structures*, Bruhn."
24. NAS 1348. 1979. "Fasteners—Recommended Tensile Stress Areas for External Threaded." Aerospace Industries Association of America. (as reported by Bickford, John H. and Sayed Nassar. 1998. *Handbook of Bolts and Bolted Joints*, p. 135, Marcel Dekker, Inc.)
25. SAE MA1520, Rev. A. 2006. "Areas for Calculating Stress or Load Values for Metric MJ Externally Threaded Fasteners."
26. NASA-STD-5001B, "Structural Design and Test Factors of Safety for Spaceflight Hardware." 08-06-2014.
27. Light, D.J. "Vibration Loosening of Threaded Fastenings." Chartered Mechanical Engineer. May 1983.
28. (no longer used)
29. (no longer used)
30. JSC-62959. "Pan/Tilt Unit Fastener Test Report." NASA/JSC. May 2005.
31. JSC-63083. "Inspection Boom Assembly and Shuttle Remote Manipulator System Fastener Test Report." NASA/JSC. August 2005.
32. Report Number 630-FA. "SP7121V3 Torque/Tension Study." Reid Products Inc. December 13, 1999.

continued

## References (continued)

33. Kerley, James J., NASA/Goddard. “The Use and Misuse of Six Billion Bolts per Year.” 35<sup>th</sup> meeting of the Mechanical Failures Prevention Group. National Bureau of Standards. April 20 – 22, 1982.
34. “Unbrako Engineering Guide.” Undated live document. Deepak Fasteners Ltd, Unbrako Division. (available at <https://unbrako.com/images/downloads/engguide.pdf>)
35. Peery, David J. 1950. *Aircraft Structures*. New York, NY: McGraw-Hill Book Company, Inc.
36. Posey, Alan, NASA/Goddard. “Small Bolt Torque/Tension Report.” August 20, 2008.
37. NAS498. “Fasteners, Alloy Steel Externally Threaded, 95 KSI  $F_{su}$ , 450°F.” October 2000.
38. NASA-STD-5020. “Requirements for Threaded Fastening Systems in Spaceflight Hardware.”
  - a. Basic release, NASA-STD-5020. March 12, 2012.
  - b. Rev. A, NASA-STD-5020A. September 4, 2018.
  - c. Rev. B, NASA-STD-5020B. August 6, 2021.
39. NAS618. May 26, 2010. “Fastener, Recommended Shank, Hole, and Head-to-Shank Fillet Radius Limits For.” National Aerospace Standards Committee.
40. FED-STD-H28/2B. 1991. “Federal Standard, Screw-Thread Standards for Federal Services, Section 2, Unified Inch Screw Threads—UN and UNR Thread Forms.”
41. [members.home.nl/b.ollivier/html/drillsize-chart.htm](http://members.home.nl/b.ollivier/html/drillsize-chart.htm)
42. Steeve, B. E., and R. J. Wingate. NASA/TM-2012-217454. “Aerospace Threaded Fastener Strength in Combined Shear and Tension Loading.” March 2012.

continued

## References (continued)

43. [www.boltscience.com](http://www.boltscience.com)
44. [en.wikipedia.org/wiki/Screw\\_thread#History\\_of\\_standardization](http://en.wikipedia.org/wiki/Screw_thread#History_of_standardization)
45. [en.wikipedia.org/wiki/Screw](http://en.wikipedia.org/wiki/Screw)
45. [sizes.com/tools/thread\\_history.htm](http://sizes.com/tools/thread_history.htm)
46. (no longer used)
47. ASME B1.13M-2005. "Metric Screw Threads: M Profile." The American Society of Mechanical Engineers.
48. (no longer used)
49. Lindeburg, Michael R. 1989. *Civil Engineering Reference Manual*, 5<sup>th</sup> ed. Professional Publications, Inc. Belmont, CA.
50. NASA Engineering and Safety Center. "Test Report: Strength Testing of Preloaded Joints." April 20, 2011.
51. [nord-lock.com/insights/knowledge/2017/the-history-of-the-bolt/](http://nord-lock.com/insights/knowledge/2017/the-history-of-the-bolt/)
52. Ramsey, John K. NASA/TM-20250005284. "Mechanics of Preloaded Bolt Tensile Loading with Focus on Load Introduction Factor." May 2025.

## Other Sources of Information

- YouTube video from “The Efficient Engineer” at [www.youtube.com/watch?v=XLzTB4KLCxU](http://www.youtube.com/watch?v=XLzTB4KLCxU).
- Green, Robert E., ed. 1996. *Machinery’s Handbook 25*, 25th ed. Industrial Press, Inc., NY.
- Bickford, John H., and Sayed Nassar, eds. 1998. *Handbook of Bolts and Bolted Joints*. Marcell Dekker, Inc., NY.
- Bickford, John H. 1995. *An Introduction to the Design and Behavior of Bolted Joints*, 3rd ed. Marcel Dekker, Inc., NY.
- Barkey, Derek, and Katherine Walker. April 12, 1989. “Design and Analysis Guide for Bolted Joints in Composite Materials.” Douglas Aircraft Company.
- MIL-HDBK-17B. 1988. “Polymer Matrix Composites.”
- MIL-HDBK-60. 1990. “Threaded Fasteners—Tightening to Proper Tension”
- Shigley, Joseph E. and Charles R. Mischke. 1986. *Standard Handbook of Machine Design*. McGraw-Hill.
- Parmley, Robert O., Editor in Chief. 1989. *Standard Handbook of Fastening and Joining*, 2nd ed. McGraw-Hill.
- Maddux, Gene E., et al. August 1969. “Stress Analysis Manual.” Air Force Flight Dynamics Laboratory.  
<https://apps.dtic.mil/sti/pdfs/AD0759199.pdf>
- “Structures Analysis Manual.” April 1988. General Dynamics Convair Division and Space Systems Division. (not marked as proprietary)  
[https://archive.org/stream/STRUCTURESANALYSISMANUALVOLI/STRUCTURES\\_ANALYSIS\\_MANUAL\\_VOL\\_I\\_djvu.txt](https://archive.org/stream/STRUCTURESANALYSISMANUALVOLI/STRUCTURES_ANALYSIS_MANUAL_VOL_I_djvu.txt)  
and  
[https://archive.org/stream/STRUCTURESANALYSISMANUALVOLII/STRUCTURES\\_ANALYSIS\\_MANUAL\\_VOL\\_II\\_djvu.txt](https://archive.org/stream/STRUCTURESANALYSISMANUALVOLII/STRUCTURES_ANALYSIS_MANUAL_VOL_II_djvu.txt)
- “Detail Aircraft Structural Analysis.” 1945. The Glenn L. Martin Company. (not marked as proprietary)
- “Structural Design Manual.” Various dates for different sections. Chance Vought Aircraft, Inc. (not marked as proprietary)
- “Structures Manual.” 1974. Rockwell International Space Division. (not marked as proprietary)
- “Engineering Practices Manual, Section M10.0, Stress Analysis Handbook.” Circa 1973. Martin Marietta. (not marked as proprietary)
- “Structural Analysis Standards, Dynamics and Stress.” August 1993. Martin Marietta Astro Space. (not marked as proprietary)

## Conversion of Units

- One inch (in or ") = 2.54 centimeters (cm) = 0.0254 meters (m)
- One mil = 0.001 in
- One micron ( $\mu\text{m}$ ) =  $10^{-6}$  m = 3.937E-5 in
- One foot (ft) = 12 in
- One pound (lb) = 4.4482 Newton (N)
- One pound of weight corresponds to 0.45359 kilogram (kg) of mass
  - Something having a mass of one kg will weigh about 2.2 lb
- One lb-s<sup>2</sup>/in of mass = 12 slug (sg)  $\cong$  175 kg
- One kip = 1000 lb
- One pound per square inch (psi) = 6894.8 Pa = 6894.8 N/m<sup>2</sup>
- One kip per square inch (ksi) = 6.8948 MPa
- $g$  = gravitational acceleration  $\cong$  386.1 in/s<sup>2</sup>  $\cong$  9.81 m/s<sup>2</sup>
- To convert between Fahrenheit ( $^{\circ}\text{F}$ ), Celsius ( $^{\circ}\text{C}$ ), and Kelvin (K):  
$$^{\circ}\text{C} = (5/9)(^{\circ}\text{F} - 32)$$
$$\text{K} = ^{\circ}\text{C} + 273.15$$

## Standard Diameters for Threaded Fasteners

Inch based		
Size	Nominal diameter, in.	Nominal diameter, mm
#2	0.0860	2.18
#4	0.1120	2.84
#6	0.1380	3.51
#8	0.1640	4.17
#10	0.1900	4.83
1/4	0.2500	6.35
5/16	0.3125	7.94
3/8	0.3750	9.53
7/16	0.4375	11.11
1/2	0.5000	12.70
9/16	0.5625	14.29
5/8	0.6250	15.88
3/4	0.7500	19.05
7/8	0.8750	22.23
1	1.0000	25.40

Closest counterpart

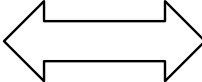

Metric (M, MJ)		
Size	Nominal diameter, mm	Nominal diameter, in.
M2	2.00	0.0787
M3	3.00	0.1181
M3.5	3.50	0.1378
M4	4.00	0.1575
M5	5.00	0.1969
M6	6.00	0.2362
M8	8.00	0.3150
M10	10.00	0.3937
M11	11.00	0.4331
M12	12.00	0.4724
M14	14.00	0.5512
M16	16.00	0.6299
M20	20.00	0.7874
M22	22.00	0.8661
M24	24.00	0.9449

Definitions of Variables for Design and Analysis of Bolted Joints

Revised August 2025

Variable	Definition
$\alpha$	coefficient of thermal expansion (CTE)
$\alpha_b$	CTE for bolt material
$\alpha_c$	CTE for clamped material
$\Gamma$	preload variation (uncertainty)
$\Gamma_{\alpha-max}$	actual extreme variation for maximum preload, as determined from a sample of torque-tension test data
$\Gamma_{\alpha-min}$	actual extreme variation for minimum preload, as determined from a sample of torque-tension test data
$\delta_e$	elastic deformation of a fastening system at rupture under tensile loading
$\delta_p$	plastic deformation of a fastening system at rupture under tensile loading
$\Delta L$	length change
$\Delta T$	temperature change
$\varepsilon$	strain
$\lambda$	knockdown factor used to account for analysis uncertainty
$\mu$	coefficient of friction for use in joint-slip analysis
$\pi$	pi
$\sigma$	stress
$\tau$	true-position tolerance on hole location
$\phi$	stiffness factor
$a$	dimension applicable to a specific figure
$a$	scaling factor for use in calculating margins of safety
$A_{eff}$	effective cross-sectional area of a bolt
$A_m$	minor-diameter area
$A_s$	full-diameter shear area (cross-sectional area of a fastener's full-diameter body)
$A_{se}$	shear area (a.k.a. shear-engagement area) for external threads
$A_{se-max}$	maximum shear area for external threads, as calculated by geometry
$A_{se-min}$	minimum shear area for external threads, as calculated by geometry
$A_{se-design}$	design shear area for external threads engaged in a tapped hole
$A_{si}$	shear area (a.k.a. shear-engagement area) for internal threads
$A_{si-max}$	maximum shear area for internal threads, as calculated by geometry
$A_{si-min}$	minimum shear area for internal threads, as calculated by geometry

Variable	Definition
$A_{si-design}$	design shear area for internal threads of a tapped hole
$A_t$	tensile stress area
$b$	dimension applicable to a specific figure
$c$	scaling factor used for estimating bolt stiffness
$d_c$	initial diameter of fitting compression zone
$d_{e-major}$	major diameter of external threads
$d_{e-major,max}$	maximum major diameter of external threads
$d_{e-major,min}$	minimum major diameter of external threads
$d_{e-minor,max}$	maximum minor diameter of external threads
$d_{i-minor}$	minor diameter of internal threads
$d_{i-minor,max}$	maximum minor diameter of internal threads
$d_{i-minor,min}$	minimum minor diameter of internal threads
$d_m$	mean diameter of threaded hole (assumed equal to $d_{pi}$ )
$d_{pe}$	pitch diameter of external threads
$d_{pe,max}$	maximum pitch diameter of external threads
$d_{pe,min}$	minimum pitch diameter of external threads
$d_{pi}$	pitch diameter of internal threads
$d_{pi,max}$	maximum pitch diameter of internal threads
$d_{pi,min}$	minimum pitch diameter of internal threads
$d_{wf}$	washer-face diameter for bolt head
$D$	nominal fastener diameter and basic major diameter (assumed herein to be equal to the diameter of the nonthreaded body of the shank)
$D_{b-max}$	maximum diameter of fastener for sizing of clearance holes
$D_{h-max}$	maximum diameter of clearance hole
$D_{h-min}$	minimum diameter of clearance hole
$D_{min}$	minor diameter
$e$	shortest in-plane distance from center of hole to edge of any clamped part other than washers
$E$	modulus of elasticity (a.k.a. "Young's modulus" and "elastic modulus")
$E_b$	modulus of elasticity for bolt material
$E_c$	modulus of elasticity for clamped material or fitting
$f$	limit stress
$f_{br}$	bearing stress

Variable	Definition
$f_{bru}$	design ultimate bearing stress
$f_{bry}$	design yield bearing stress
$f_{bu}$	design ultimate bending stress
$F$	allowable stress; also used to denote fillet juncture diameter at bearing surface for socket head cap screws
$F_{bru}$	allowable bearing ultimate stress
$F_{bry}$	allowable bearing yield stress
$F_{bu}$	allowable ultimate stress for plastic bending
$F_{pl}$	Proportional limit
$F_{su}$	allowable ultimate shear stress
$F_{su-e}$	allowable ultimate shear stress for external threads
$F_{su-i}$	allowable ultimate shear stress for internal threads
$F_{tu}$	allowable ultimate tensile stress
$F_{ty}$	allowable tensile yield stress
$FF$	fitting factor
$FF_{sep}$	separation fitting factor
$FF_u$	ultimate fitting factor
$FF_y$	yield fitting factor
$FS$	factor of safety
$FS_{sep}$	separation factor of safety
$FS_u$	ultimate factor of safety
$FS_y$	yield factor of safety
$H$	dimension associated with threads
$j$	test number
$k_b$	bolt stiffness
$k_c$	stiffness of clamped parts ("clamp stiffness")
$k'_c$	effective clamp stiffness (accounting for the loading-plane factor)
$K$	nut factor (a.k.a. "torque coefficient")
$K_{max}$	maximum nut factor
$K_{min}$	minimum nut factor
$K_{nom}$	nominal nut factor
$L$	length of tensile specimen
$L$	total thickness of clamped parts other than washers
$L_b$	effective bolt length

Variable	Definition
$L_e$	length of thread engagement
$L_{lp}$	distance between loading planes
$L_1$	bolt grip
$L_2$	dimension used for calculating bolt stiffness
$m$	distance from reference surface to neutral axis for prying
$m$	number of tests (sample size)
$M_1$	moment about the 1 axis
$M_2$	moment about the 2 axis
$M_{1-cen}$	moment about the 1 axis at the bolt-pattern centroid
$M_{2-cen}$	moment about the 2 axis at the bolt-pattern centroid
$M_x$	moment about the x axis
$M_y$	moment about the y axis
$M_z$	moment about the z axis
$MS$	margin of safety
$MS_{sep}$	separation margin of safety
$MS_{slip}$	margin of safety for joint slip
$MS_u$	ultimate margin of safety
$MS_y$	yield margin of safety
$n$	threads per inch
$n$	loading-plane factor (a.k.a. load-introduction factor)
$n_f$	number of fasteners in a joint
$n_t$	number of threads engaged
$n_{t,min}$	minimum number of threads engaged
$p$	pitch
$P$	applied load (force)
$P'$	allowable applied load
$P_{\Delta t}$	additional tensile force in bolt and compressive force in fittings caused by temperature change
$P_{\Delta t-max}$	maximum preload increase caused by temperature change at maximum or minimum expected temperature
$P_{\Delta t-min}$	calculated maximum preload decrease (as a positive number) caused by temperature change at maximum or minimum expected temperature
$P_{allow}$	allowable load for a fastener or other part
$P_{br}$	bearing load acting on a plate from a single fastener

Variable	Definition
$P_{bru\text{-allow}}$	allowable bearing ultimate load for a fastener
$P_c$	compressive load
$P_f$	friction load that can be developed in a shear joint
$P_L$	limit load
$P_p$	preload
$P_{p\text{-max}}$	maximum preload
$P_{p\text{-min}}$	minimum preload
$P_{pc}$	calculated maximum expected preload loss (as a positive number) from material creep
$P_{pi}$	initial preload
$P_{pi\text{-}j}$	initial preload obtained in the j-th test
$P_{pi\text{-max}}$	maximum initial preload
$P_{pi\text{-maxa}}$	actual maximum initial preload from a sample of test data
$P_{pi\text{-min}}$	minimum initial preload
$P_{pi\text{-mina}}$	actual minimum initial preload from a sample of test data
$P_{pi\text{-nom}}$	nominal initial preload, equal to the sample mean (average) preload for a given effective torque
$P_{po\text{-allow}}$	allowable pull-out load for external or internal threads with bolts in tapped holes in solid blocks of material
$P_{poe\text{-min}}$	calculated minimum pull-out strength for external threads using $A_{se\text{-min}}$
$P_{poe\text{-allow}}$	allowable pull-out load for external threads of bolts in tapped holes in solid blocks of material
$P_{poi\text{-min}}$	calculated minimum pull-out strength for internal threads using $A_{si\text{-min}}$
$P_{poi\text{-allow}}$	allowable pull-out load for internal threads in tapped holes in solid blocks of material
$P_{pr}$	short-term relaxation in preload
$P_{sep}$	design separation load
$P'_{sep}$	calculated separation load when at maximum preload
$P_{sl}$	limit shear load for a bolt
$P_{sl\text{-joint}}$	total limit shear load acting on the joint
$P_{su}$	design ultimate shear load for a bolt
$P_{su\text{-}n}$	allowable ultimate shear load for a bolt in a shimmed single-shear joint
$P_{su\text{-allow}}$	allowable ultimate shear load per shear plane for a bolt
$P_{sy}$	design yield shear load for a bolt (for use in bearing analysis)
$P_t$	applied tensile load acting on a bolt
$P_{th}$	total tensile load in a bolt
$P_{thu}$	total tensile load in a bolt under the design ultimate tensile load

Variable	Definition
$P_{t\text{-joint}}$	tensile load acting on joint
$P_{tl}$	limit (applied) tensile load for a bolt
$P_{tl\text{-allow}}$	allowable limit tensile load for a bolt (based on separation criteria)
$P_{tl\text{-joint}}$	total limit tensile load acting on the joint
$P_{tu}$	design ultimate (applied) tensile load acting on a bolt
$P'_{tu}$	allowable applied ultimate tensile load (applied tensile load that causes the bolt load to exceed the allowable ultimate tensile load for the fastening system) if rupture may occur before separation
$P_{tu\text{-allow}}$	allowable ultimate tensile load for a fastening system and allowable applied ultimate tensile load if separation would occur before rupture
$P_{ty}$	design yield (applied) tensile load acting on a bolt
$P'_{ty}$	allowable applied tensile yield load (applied tensile load that causes the bolt load to exceed the allowable tensile yield load for the fastening system) if yielding occurs before separation
$P_{ty\text{-allow}}$	fastener's allowable yield tensile load (applicable when yielding is detrimental)
$P_x$	applied force in the x direction
$P_y$	applied force in the y direction
$P_z$	applied force in the z direction
$r_{\max}$	maximum root radius
$r_{\min}$	minimum root radius
$s$	fastener spacing
$t$	thickness
$t_w$	average washer thickness
$T$	effective torque (total torque minus running torque from locking feature)
$T_{br\text{-min}}$	minimum breakaway torque, as specified for the locking feature
$T_{l\text{-max}}$	maximum locking torque (running torque), as specified for the locking feature
$T_{\max}$	maximum effective torque
$T_{\min}$	minimum effective torque
$T_{s\text{-max}}$	maximum specified torque value
$T_{s\text{-min}}$	minimum specified torque value
$w$	running load, force per unit length
$y$	distance from a reference surface to a bolt pattern's centroid

## 1. Overview

- Common Problems with Bolted Joints
- Designing a Bolted Joint
- Common Required Characteristics for Structures
- General Design Guidelines for Bolted Joints
- The Importance of Preload
- Introduction to NASA-STD-5020
- Key Definitions
- High-level Requirements from NASA-STD-5020B
- Margin of Safety
- Fastening System Control Plan
- Establishing Internal Standards and Criteria

Permission is granted by Instar for anyone to freely copy, distribute, and print this material, but only in its unaltered form. This section may be separately copied or printed, but only in its entirety, including this page and with headers and footers intact. Unaltered individual figures and tables and portions of text may be copied or used, but only with text in quotes and with the following statement "Source: Design and Analysis of Bolted Joints (DABJ) course book, Thomas P. Sarafin, Instar Engineering and Consulting, Inc. Reproduced with permission." The date of last revision also should be included in the reference. If you have questions, contact [tom.sarafin@instarengineering.com](mailto:tom.sarafin@instarengineering.com).

## Common Problems with Bolted Joints

### Problem

Something in the joint ruptures in test or in service



Joint undergoes detrimental permanent deformation

Joint adds unacceptable loss of stiffness or nonlinear stiffness

### Usual or Possible Causes

- Inadequately designed
  - Poor load paths
  - Failure mode not recognized
  - Inadequately assessed
  - Mismatched hardware
  - Inadequate thread engagement
  - Unanticipated peak load or load distribution
  - Manufacturing tolerances not considered
- Lack of development testing
- Poor quality of hardware or assembly
- Inadequate preload leading to fatigue failure
- Corrosion
  
- Many of the above causes
- Unanticipated slipping of joint under shear load
- Required alignment not understood during design
- Inappropriate analysis methods or design data used
  
- Poor load paths
- Inadequate preload
- Lack of development testing when stiffness is critical



continued

## Common Problems with Bolted Joints (continued)

### Problem

Joint loosening (loss of preload), resulting in low, nonlinear stiffness and potential fatigue failure

Nut or screw rotating and coming off completely

Difficult (time consuming and costly) assembly and disassembly:

- Hard to access
- Special tools needed
- Threaded parts binding up
- Match drilling in a clean room

Protruding fasteners causing system failure

- Physical interference
- Short circuit

Costly issues arising late in the program, and customers and contractors disagreeing on how to analyze a joint or a bolt

### Usual Causes

- Cyclic joint slip within clearance holes
- Yielding in fastener or clamped parts
- Creep of materials in preload path
- Lack of an effective locking feature
- Assembly process not considered in design
- Mismatched thread forms
- Incompatible materials
- Lack of attention to detail during design
- Loss of configuration control; decisions based on data (e.g., from engineering drawings) that does not agree with the actual configuration
- Inadequate attention to detail during design
- Lack of applicable test data or empirical methods
- Lack of an accepted standard

## Representative Fastener Issues on the Space Shuttle and International Space Station Programs

1996 Space Shuttle mission (STS-80): The crew could not open the external airlock hatch; as a result, planned extravehicular activities (EVAs) were scrubbed. A small screw with no locking feature had backed out and jammed a gear in the hatch mechanism.

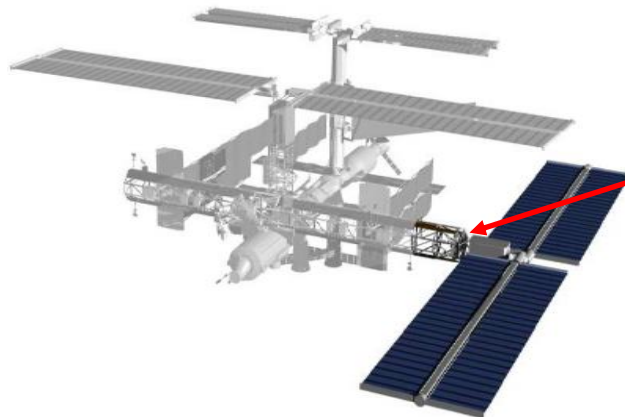

In a 2006 EVA, while astronauts tried to activate the Solar Alpha Rotary Joint on the International Space Station, a bolt in the launch restraint seized and required extremely difficult removal, injuring a crew member.

Continued on next page

Adapted from “Fastener Issue Overview Within NASA Manned Space Flight Programs,” Chris Hansen, Feb 7, 2007

## Representative Fastener Issues on the Space Shuttle and International Space Station Programs (cont'd)

Payload rack structure for the Multi-Purpose Logistics Module (MPLM): Hundreds of fasteners too short to fully engage threads and engage the locking feature, not detected during installation. Running torque had not been verified for the fasteners during assembly.

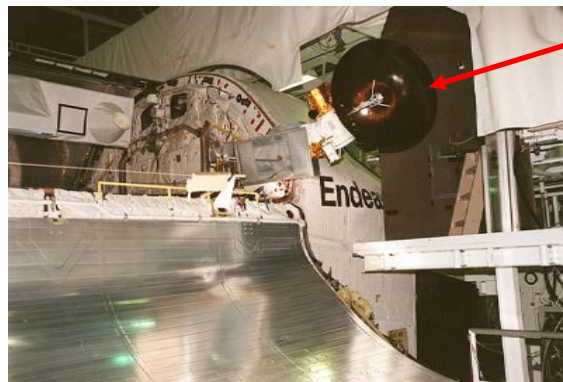

Space Shuttle Ku Band Antenna: After multiple missions, 2 of 4 main attachment bolts were discovered in 2006 to be too short to engage locking features or provide adequate strength; required risky repair on launch pad.

During a 2006 Shuttle mission, an EVA camera came loose and was lost because the mounting screws backed out.



These issues and many others led to the development of NASA-STD-5020

## Designing a Bolted Joint

Where discussed  
Sec. 1

Sec. 3

Sec. 1

Secs.  
3 – 6,  
10

Sec. 7

Secs.  
8 & 9

↑ Iterate as needed ↓

1. Identify functional requirements and constraints for the structure being designed.
2. Develop a concept for the structure, including ...
  - Method of attachment: welding, bonding, or fastening
  - Concept for the joint: configuration, types of fasteners, access for assembly
3. Derive requirements and design considerations for the joint.
  - Life-cycle environments, design loads, loading cycles, temperatures
  - Required stiffness, allowable permanent deformation, design criteria
  - Cost, lead time, ease of assembly, schedule
4. Size the joint.
  - Select bolt pattern
  - Calculate bolt loads; size bolts
  - Identify potential failure modes in the **fittings** (regions of joined parts near bolts), a.k.a. **joint members**, and appropriate methods of assessment
  - Size fittings
5. Select hardware and design details.
  - Specific bolts, nuts, washers, pins
  - Edge distance, wrench clearance, hole size
  - Assembly requirements (e.g., lubrication, torque, torque sequence)
6. Perform detailed analysis.

### Goal: a joint that ...

- functions as needed throughout its intended life cycle
- uses affordable and available hardware
- is easy to assemble and disassemble

## Definitions for This Course: Commonly Required Characteristics for Structures

**Strength:** the highest load a structure can carry (or stress a material can withstand) without failure when the load is applied a single time. Failure can be ...

- rupture or collapse (**ultimate failure**), so the structure requires a certain **ultimate strength**,
- or detrimental permanent deformation—often referred to as **yield failure**, but a joint slipping through bolt clearance holes can have the same consequence (e.g., misalignment in an alignment-critical assembly), so the structure requires a certain **yield strength**.

**Structural life:**

- the number of loading cycles a structure can withstand before rupture (**fatigue life**)
- or the duration of exposure to an environment before the structure fails (can be associated with material creep or corrosion)

**Stiffness:** the load caused by unit displacement (typical units: lb/in or N/cm)

- Often a requirement derived to achieve a target natural frequency

**Seal:** ability to contain a pressurized gas or liquid

**Start with an understanding of the applicable requirements.**

## Design Structures to Minimize Joints!

**When disassembly is not required,  
the best way to avoid problems with joints is to not have joints.**

### How?

- Large parts rather than assemblies of many small ones
  - Integral machining
  - Additive manufacturing (3D printing)
  - Investment casting
- Forms of construction that can mount equipment without structural adapters
  - Machined isogrid (shown above right)
  - Orthogrid (machined waffle pattern with rectangular cells)

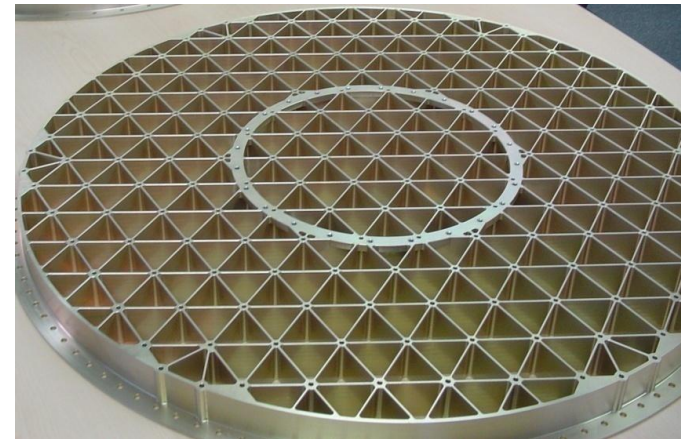

**A structure with fewer joints,  
hence fewer parts, is usually ...**

- less costly
- more predictable
- more trouble-free

## Use Proven Designs!

We have empirical, semi-empirical, and traditional methods of analysis for many types of joints.

– although we need a lot more, as discussed in this course!

Many of these methods apply only when the joint's materials are ductile and when using bolts and designing joints in a manner that takes advantage of ductility.

– Make sure you understand the basis and limitations of the method—a subject explored in this course as well.

**To reduce risk or the need for development testing, design bolted joints to be like those that have been tested before and have empirical or semi-empirical methods of analysis.**

**If you need a new type of joint, test it early, before committing to the design!**

## Most Bolted Joints Don't Work Without Preload

**Tightening the nut or bolt creates a tensile load in the bolt and an equal clamp load between fittings. It's the clamp load that's important.**

A high preload ...

- minimizes cyclic loading in the fastener; increases fatigue life
- increases a joint's stiffness
- keeps shear joints from slipping back and forth within clearance holes; prevents **fretting** (corrosion resulting from breakdown of protective oxides on surfaces from rubbing)
- helps maintain alignment
- helps lock the fastener in place



But too high of a preload ...

- may cause bolts to fail during installation (combined effects of tension and torsion)
- may cause excessive yielding during installation, using up much of the bolt material's elongation and leading to greater risk of rupture under applied load
- may crush a clamped brittle material

### Design challenges:

- 1. Establishing the right preload at assembly**
- 2. Maintaining preload during service**

← addressed in Sec. 7

## How a Preloaded Joint Carries Applied Tensile Load

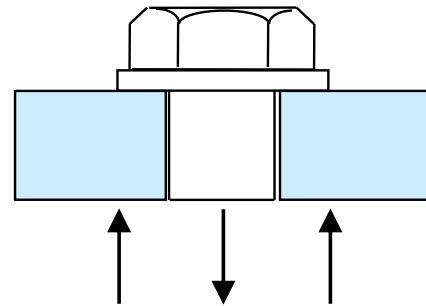
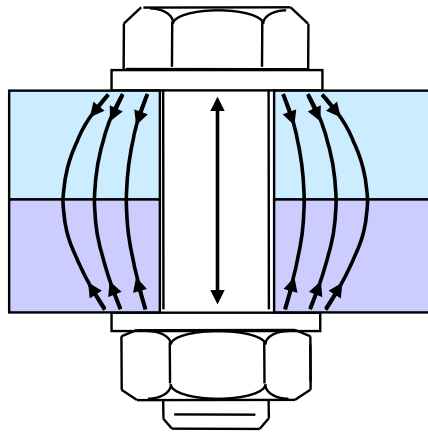

Free-body diagram.  
Compressive load between fittings equal to bolt tensile load

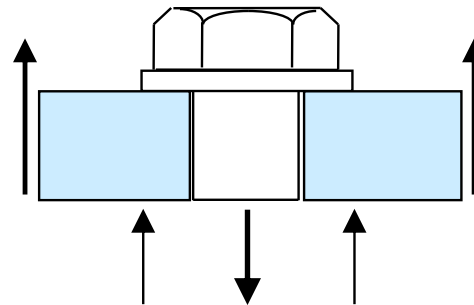
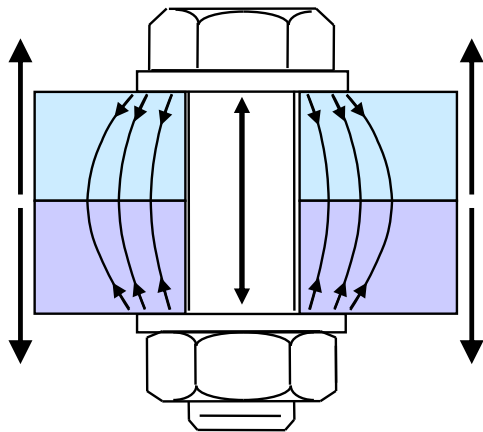

Bolt load increases,  
compression between fittings decreases

When we torque a bolt or a nut, the bolt is preloaded in tension, and the fittings are preloaded in compression.

Under applied tension, there are two load paths acting like springs in parallel: bolt load goes up and clamp force goes down.

In most joints, the bolt load changes as a small percentage of applied load until the joint gaps. (Explored in Sec. 8)

## How a Preloaded Joint Carries Shear

Applied shear is initially carried by friction in a clamped joint:

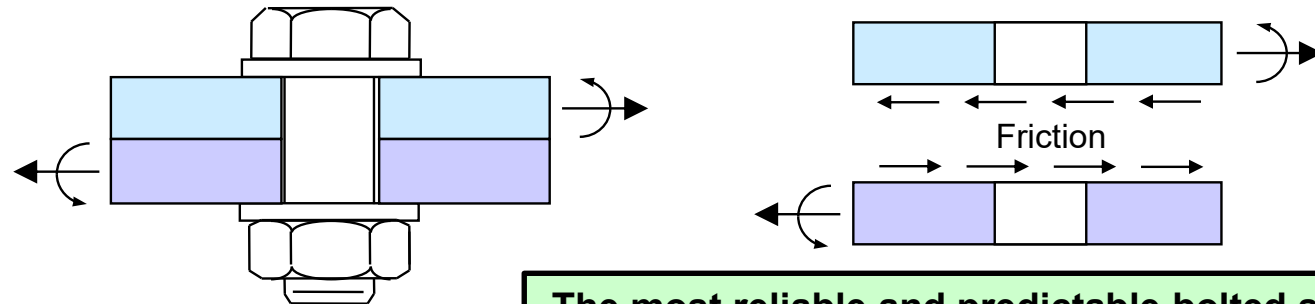

If the applied load overcomes friction capability, the joint slips and loads the bolt.

Slipping causes nonlinear structural behavior and potentially detrimental deformation, and it can lead to potentially damaging shock when the bolt hits the surface of the hole.

Cyclic slip can lead to fretting and causes loss of preload (even with most locking features—see Sec. 7), and eventually a loose joint.

**The most reliable and predictable bolted shear joint has one or more features that prevent joint slip:**

- Sufficient preload for friction to carry the applied load
- Interference-fit shear pins or other mechanical features
- Tight (match drilled and reamed) bolt holes

**Nearly every bolted joint in an automobile and in heavy machinery is designed to carry shear by friction.**

(Ref. John Ness, Matrix Engineering, LLC)

**But we don't always adhere to this guidance in the space industry ...**

## How Important Is It To Prevent Joint Slip?

Preventing slip is essential for joints in assemblies that will see cyclic loading over years of service.

But many single-mission space and launch vehicles have flown successfully with joints that can slip—when those joints are designed properly for shear loading:\*

- Bolts of a type having a full-diameter body (often referred to as the “shank”, but the ASME defines “shank” as the full body under the head, whether threaded or not)
- Threads not in the shear plane or in bearing (bolt used with a nut rather than installed in a tapped hole or threaded insert)
- Bolt holes as tight as is practical with CNC machining and true-position tolerancing (Match drilling and reaming is not usually necessary when there are few potential slip cycles.)
- High preload to maximize friction capability and minimize potential slip cycles.

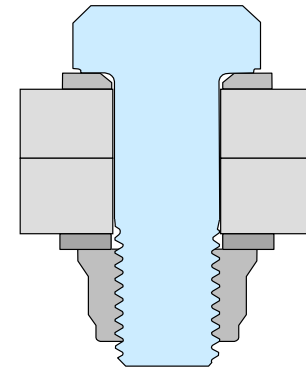

\*And as long as the permanent deformation associated with slip is not detrimental; it may be detrimental for instruments and other precision items.

## Introduction to NASA-STD-5020

### “Requirements for Threaded Fastening Systems in Spaceflight Hardware”

Originally released in March 2012 (Ref. 38a), revised to NASA-STD-5020A (Ref. 38b) in September 2018 and NASA-STD-5020B (Ref. 38C) in August 2021

**The scope of the standard includes design, analysis, installation, verification, and quality assurance.**

- NASA-STD-5020 replaced NSTS 08307 (Ref. 7) as the standard for analysis of preloaded bolts.
  - Includes significant changes in analysis methodology
  - Supporting justification provided in an appendix
- And goes beyond NSTS 08307 by addressing ...
  - design considerations such as locking features, preloading, grip length, and material selection
  - verification and quality assurance
  - responsibilities of the hardware developer

## **Development and Revision of NASA-STD-5020**

- Development of the baseline release was a 5-year effort (2007 – 2012) by a large team consisting of NASA civil servants, researchers, consultants, and employees of NASA prime contractors.
  - Chris Hansen, at that time the mechanical lead for NASA’s Engineering and Safety Center (NESC), obtained approximately \$4M budget and formed the original team.
  - Mike Dube of the NESC managed the 5020 development project.
  - Released in March 2012.
- In 2016, Revision A (5020A) began with a much smaller team (NASA civil servants only; mostly members of the original 5020 team).
  - Released in September 2018
  - Significant changes, mostly reflecting a new philosophy of not requiring any particular equations or methods of analysis
- Revision B (5020B) was released in August 2021.
  - Refers to NASA-STD-8739.14 (Ref. 10) instead of NASA-STD-6008 for fastener procurement, receiving inspection, and storage
  - Otherwise relatively minor changes (typo cleanup)

## **NASA-STD-5020B Contents Overview**

1. Scope
  2. Applicable Documents
  3. Acronyms, Abbreviations, Symbols, and Definitions
  4. Requirements
- Appendix A. Explanation and Justification of Fastener Analysis Criteria
- Appendix B. Best Practices for Locking Features
- Appendix C. Justification for Low Likelihood of Fatigue Failure
- Appendix D. References
- Appendix E. Requirements Compliance Matrix (new in Rev. A)

## **Contents of NASA-STD-5020B Sec. 4, Requirements**

- 4.1 Fastening System Control Plan
- 4.2 Design Factors
  - 4.2.1 Factor of Safety
  - 4.2.2 Fitting Factor
  - 4.2.3 Separation Factor of Safety
- 4.3 Fastening System Preload
  - 4.3.1 Maximum and Minimum Preload
  - 4.3.2 Nominal Preload
- 4.4 Strength Requirements
  - 4.4.1 Ultimate Design Loads
  - 4.4.2 Yield Design Loads
  - 4.4.3 Separation Loads
  - 4.4.4 Combination of Loads
  - 4.4.5 Inclusion of Preload in Yield and Ultimate Load Strength
- 4.5 Fatigue Life
- 4.6 Locking Features
  - 4.6.1 Preload Independent Locking Feature
  - 4.6.2 Mechanical Locking Feature
  - 4.6.3 Liquid Locking Compound Process Control
  - 4.6.4 Locking Feature Verification
- 4.7 Part Selection Criteria
  - 4.7.1 Materials
  - 4.7.2 Thread Form Compatibility
  - 4.7.3 Use of Washers and Chamfered Bolt Holes
  - 4.7.4 Fastener Length Selection for Thread Engagement
  - 4.7.5 Bolt Grip Selection to Prevent Interference
- 4.8 Quality Assurance
  - 4.8.1 Design Documentation
  - 4.8.2 As-Built Documentation
  - 4.8.3 Training
  - 4.8.4 Tools and Instruments
  - 4.8.5 Threaded Fastening System Hardware Inspection
  - 4.8.6 Fastening System Hardware Procurement, Inspection, and Storage

## Key Definitions

(adapted from NASA-STD-5020B unless otherwise noted)

**Fastener:** A bolt or a screw that joins two or more parts and transfers load between them.

**Threaded fastening system** (a.k.a. “fastening system”): An assembled combination of a fastener, an internally threaded part such as a nut or an insert, and the region of all parts, including washers, compressed by the fastener preload.

**Applied load** (a.k.a. “external load,” “externally applied load,” and “service load”): Force or moment transferred across a joint, including load transferred across a joint as a result of thermally induced loading of the structure. Applied load does not include preload or changes in preload as a result of temperature change.

**Preload:** The tensile force in a bolt and the equivalent compressive force in the joint members (fittings) when there is no applied load.

**Limit load:** The maximum expected applied load.

## More Key Definitions

(adapted from NASA-STD-5020B except for clarification statements)

**Factor of safety (FS):** A multiplying factor to be applied to limit loads for purposes of analytical assessment (design factor) or test verification (test factor) of design adequacy in strength or stability.

- Clarification: Different factors of safety typically apply for ultimate strength, yield strength, fatigue, and separation.

**Fitting factor (FF):** A supplemental factor of safety used in analysis of bolted joints to account for uncertainties in load paths and stresses.

- Clarification: Different fitting factors may apply for ultimate strength, yield strength, fatigue, and separation.

**Ultimate design load** (a.k.a. “design ultimate load”): Limit load multiplied by the ultimate factor of safety and the applicable fitting factor.

**Yield design load** (a.k.a. “design yield load”): Limit load multiplied by the yield factor of safety and the applicable fitting factor.

## More Key Definitions

(from NASA-STD-5020B except as noted and for the stated example)

**Allowable load:** The maximum permissible load in a structural part or assembly. As applicable, it can be

- the specified strength of the hardware (e.g., in a fastener specification);
- a statistically based, lower-bound, load-carrying capacity derived from test data;
- or the load derived from the allowable stress of the materials.

**Allowable stress** (my definition, not in NASA-STD-5020B): The minimum strength of a material at a particular statistical basis (usually A-basis: 99% probability, 95% confidence).

**Allowable applied load** (adapted from a definition in NASA-STD-5020 basic release, which is not in Rev. A or Rev. B): The maximum permissible applied load, which is derived from the allowable load.

- Example: The allowable applied ultimate tensile load acting on a bolt is the applied load that causes the total bolt load, when accounting for preload, to equal the allowable ultimate tensile load for the fastening system. (See Sec. 9 of this course.)

## More Key Definitions

(adapted from NASA-STD-5020B except for clarification statements)

**Separation** (also referred to as **gapping**): The state of no compressive load between mating parts local to the fastener. For a joint designed to maintain a seal, gapping is further defined as any condition that enables a liquid or gas to penetrate the seal at an unacceptable rate.

**Separation load:** The minimum applied tensile load that causes separation.

- My clarification: Can be thought of as the allowable load for ensuring no separation.

**Design separation load:** The limit tensile load multiplied by the separation factor of safety.

- My clarification and preferred wording: “The limit tensile load multiplied by the separation factor of safety and the applicable fitting factor.”

**Separation-critical Joint:** A joint that fails to function as required if separated.

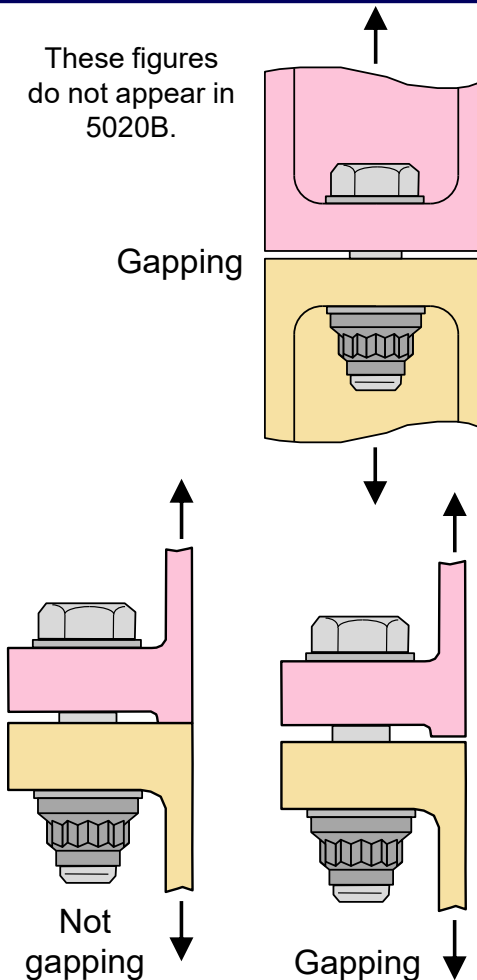

## Opening Comments on NASA-STD-5020B Requirements

- With a traditional systems engineering approach, requirements stem from functions and constraints.
  - What the product or system must do, such as put a satellite into orbit,
  - within certain constraints, such as envelope, environments, and not-to-exceed mass
- The most basic function of a space or launch vehicle structure is to physically support other items in their needed positions despite the constraints of ground, launch, and space environments.
- In this sense, the “shall” statements in NASA-STD-5020B, as well as other NASA standards are not true requirements but instead are criteria for design, analysis, assembly, and test to ensure high reliability.
  - In other words, these “shall” statements are criteria for verification, often verification of compliance with the requirement associated with the above basic function.
- However, most NASA programs have historically treated “shall” statements in applicable standards like any other requirement, requiring formal verification.
- Recently, though, NASA has become more open to tailoring of the “shall” statements within standards. (See next page.)

## Appendix E in NASA-STD-5020B (first included in 5020A) Requirements Compliance Matrix

Opening text in Appendix E (bold red font added here for emphasis):

Due to the complexity and uniqueness of space flight, it is unlikely that all of the requirements in a NASA technical standard will apply. The Requirements Compliance Matrix below ... **may be used by programs and projects to indicate requirements that are applicable or not applicable to help minimize costs.** Enter “Yes” in the “Applicable” column if the requirement is applicable to the program or project or “No” if the requirement is not applicable to the program or project. The “Comments” column may be used to provide specific instructions on how to apply the requirement or to specify proposed tailoring.

Any such tailoring must be approved by the NASA program authority.

### Bottom line:

**If any of the NASA-STD-5020B requirements are driving cost, schedule, or weight unreasonably for your program, petition the program authority with technical justification for deleting those requirements and doing something different instead.**

When I asked the NASA-STD-5020A team for some background information on Appendix E, I was told that it will be included in all NASA standards to promote tailoring.

## High-Level Requirements in NASA-STD-5020B: Ultimate Design Loads

### 4.4.1 Threaded fastening system hardware shall withstand ultimate design loads without failure when subjected to:

- a. the accompanying service environments (for example, temperature) and
- b. a coefficient of friction between clamped parts equal to zero (applicable only to verification by analysis, not applicable to verification by test).

*The term “failure”, as used above, is the inability to meet any performance requirements applicable at ultimate load. Examples include rupture of the joint and leaking of a joint that can credibly lead to a catastrophic hazard.*

Ultimate factor of safety,  $FS_u$ , is as specified by the program, typically per NASA-STD-5001B (Ref. 26)

#### Definition of catastrophic hazard per NASA-STD-5020B:

- (1) A hazard that could result in a mishap causing fatal injury to personnel, and/or loss of one or more major elements of the flight vehicle or ground facility.
- (2) A condition that may cause death or permanently disabling injury, major system or facility destruction on the ground, or loss of crew, major systems, or vehicle during the mission

## Is Ultimate Strength Analysis Not Required by NASA-STD-5020B?

The following explanatory, italicized text for the Ultimate Design Loads requirement in NASA-STD-5020B Sec. 4.4.1 first appeared in 5020A.

*Withstanding ultimate design loads can be demonstrated by test or by analysis where a non-negative margin of safety is calculated.*

A similar sentence appears after the Yield Design Loads requirement (Sec. 4.4.2).

- This sentence implies that it is not required to show non-negative margins of safety with ultimate (or yield) strength analyses if there will be a test to the design ultimate (or yield) load.
- However, without analysis, how can we become confident that the test will be successful?
- I'm sure most, if not all, NASA programs still expect to see non-negative strength margins before designs are released and tests are performed.
- But, in some cases, particularly when a margin turns negative after the hardware is built (e.g., from increased limit loads), NASA may accept strength verification by test alone.
- Be cautious, though: Given build-to-build variation, one structure passing a test doesn't always ensure the next structure built to that design will have adequate strength.

## High-Level Requirements in NASA-STD-5020B: Yield Design Loads

**4.4.2 Threaded fastening system hardware shall withstand yield design loads without detrimental yielding or detrimental deformation when subjected to the accompanying service environments (for example, temperature).**

*Yield strength analysis is not required if there is no detrimental yielding or detrimental deformations at the yield design load.*

Yield factor of safety,  $FS_y$ , is as specified by the program, typically per NASA-STD-5001.

My interpretation:  
Yield strength analysis is not required if we can show that either (a) yielding is not detrimental or (b) meeting other analysis criteria (e.g., gapping) ensures there will be no detrimental yielding at the design yield load.

Definition of **detrimental yielding** per NASA-STD-5020B:

Yielding that adversely affects fit, form, function, or integrity of the structure

## High-Level Requirements in NASA-STD-5020B: Fatigue Life

**4.5 All threaded fastening systems shall be designed to withstand the entire service life, including the life scatter factor specified by the program or project, and service environment without fatigue failure.**

We'll explore this requirement in Sec. 9.

## High-Level Requirements in NASA-STD-5020B: Separation

**4.4.3 Threaded fastening system hardware shall withstand design separation loads (limit load times the separation factor of safety and fitting factor) without loss of compression between the joint members or detrimental deformation due to separation when subjected to the accompanying service environments (for example, temperature).**

According to the lead engineer on the NASA-STD-5020A team, in response to my question, the wording “without loss of compression” is referring to detrimental loss of compression.

The explanatory text in NASA-STD-5020B Sec. 4.4.3 says ...

*Withstanding design separation loads can be demonstrated by test or by analysis where a non-negative margin of safety is calculated.*

*Separation is not strictly prohibited in all applications. Separation may be permissible when:*

- *Separation does not cause detrimental deformations; and*
- *Separation does not cause a critical or catastrophic hazard; and*
- *Strength requirements in sections 4.4.1 and 4.4.2 are met in the separated condition; and*
- *The life requirement in section 4.5 is met when accounting for the separated condition.*

(continued)

## More from NASA-STD-5020B on Separation

*Examples of detrimental separation deformations include:*

- *Reduction in compression of a seal or gasket that enables a liquid or gas to leak at an unacceptable rate*
- *Separation that interrupts a critical electrical path*
- *Separation that degrades the thermal contact conductance between mated parts*
- *Separation that causes a change in stiffness or load path credibly leading to a load condition that causes detrimental yield or collapse of the structure*
- *Separation that reduces the fatigue life of the fastener due to an increase in the amplitude of the cyclic load*

**Acknowledgement that gapping is sometimes acceptable is a significant change from the basic release and, I think, a move in the right direction. In this course, however, I use the criterion “no separation at the design separation load”.**

## Separation Factor of Safety, $FS_{sep}$ Per NASA-STD-5020B, Sec. 4.2.3, Fig. 1

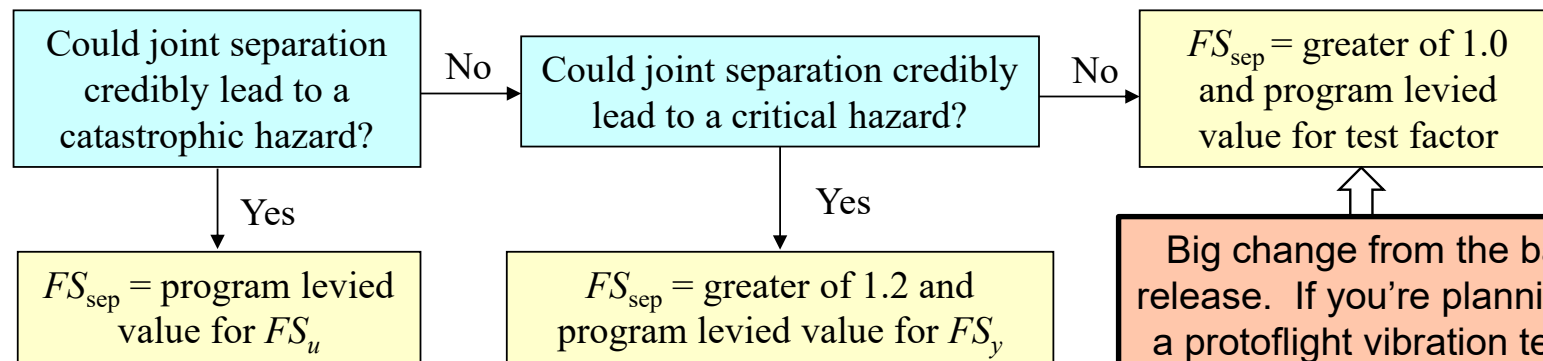

Definitions from NASA-STD-5020B:

**Catastrophic hazard:** (1) A hazard that could result in a mishap causing fatal injury to personnel, and/or loss of one or more major elements of the flight vehicle or ground facility. (2) A condition that may cause death or permanently disabling injury, major system or facility destruction on the ground, or loss of crew, major systems, or vehicle during the mission.

**Critical hazard:** A condition that may cause severe injury or occupational illness, or major property damage to facilities, systems, of flight hardware.

↑

Big change from the basic release. If you're planning on a protoflight vibration test to +3 dB, you must use a separation factor of safety of 1.4 on flight limit load when separation is detrimental.

My opinion: This might be good design practice, but it shouldn't be a requirement. I would seek approval for deleting this requirement if we have high confidence in passing the test if the joint gaps.

## Use of Fitting Factors per NASA-STD-5020B

### 4.2.2 Threaded fastening system hardware shall be designed using a fitting factor (FF).

**Note that, although it's required to use a fitting factor, there's no requirement for how high the fitting factor must be.**

Excerpts from the italicized text that follows (see 5020B Sec. 4.2.2 for additional guidance):

*Rationale: A fitting factor is included in the strength and separation analysis of each part of the threaded fastening system to account for uncertainties in load paths and stresses.*

*For purposes of analysis, joint members integral to a larger structural member are considered part of the threaded fastening system up to the point where their section properties become typical of the structural member away from the threaded fastening system.*

*Ultimate strength analysis should include a fitting factor of at least 1.15 as a multiplier of the required ultimate factor of safety. **The selection of a fitting factor for ultimate strength should be strongly influenced by whether there is enough ductility in the critical failure mode to ensure load sharing between fasteners before any one fastening system fails.***

*Yield strength analysis of threaded fastening systems whose performance is particularly sensitive to local yielding should include a fitting factor of at least 1.15.*

*Separation analysis of joints that are separation-critical should include a fitting factor of at least 1.15.*

**We'll touch on the use of fitting factors in this course.**

## Margin of Safety

**Margin of Safety:** A measure of a structure's predicted reserve strength or capability in excess of the design criteria.

The margin of safety represents the percentage that the design load (limit load,  $P_L$ , multiplied by the applicable factor of safety,  $FS$ , and fitting factor,  $FF$ ) can increase before the design criteria are no longer satisfied.

$$MS = \frac{P'}{FS \cdot FF \cdot P_L} - 1 \quad (\text{Eq. 1.1})$$

where  $P'$  is the allowable applied load

Criterion:  $MS \geq 0$

Margin of safety is traditionally reported to the nearest percent (two decimal places).

If the calculated internal load or stress is proportional to applied load, the margin of safety can be calculated as

$$MS = \frac{P_{\text{allow}}}{FS \cdot FF \cdot P_L} - 1 \quad (\text{Eq. 1.2})$$

Not the case for a preloaded bolt that can fail prior to separation (see Sec. 9 herein)

or

$$MS = \frac{F}{FS \cdot FF \cdot f} - 1 \quad (\text{Eq. 1.3})$$

where  $P_{\text{allow}}$  is the allowable load (e.g., for the fastening system),  $F$  is the allowable stress, and  $f$  is the limit stress

## Fastening System Control Plan (FSCP) per NASA-STD-5020B

**4.1 At the Preliminary Requirements Review, equivalent program review, or project milestone review, each hardware developer shall submit a Fastening System Control Plan to the delegated NASA Technical Authority that:**

- Shows how the requirements in this NASA Technical Standard are to be satisfied; and
- Includes any organization-specific requirements and criteria for design, analysis, fastener installation, and verification; and
- Captures or refers to organization-specific processes for ensuring quality and integrity.

Original reasons for inclusion of this requirement in the baseline NASA-STD-5020:

1. The FSCP allows hardware developers to demonstrate that they understand NASA-STD-5020 requirements and potential pitfalls associated with threaded fasteners, and know how to avoid those pitfalls.
2. The FSCP gives developers more ownership and responsibility, and allows opportunity for tailoring of the standard.

Rationale given in NASA-STD-5020B:

*A Fastening System Control Plan establishes a defined and approved agreement between the hardware developer and the delegated NASA Technical Authority. By agreeing to the plan early in the design, there is reduced likelihood of disagreements over verification strategies.*

## **Establish Standards and Criteria Within Your Organization**

**If your organization does the structural and mechanical design, you shouldn't expect—or want—outside organizations such as NASA to levy requirements on how to do the engineering.**

**Establish your own internal standards to ensure your products work!**

- Internally standardize to avoid problems.
  - materials
  - fasteners
  - minimum edge distances and fastener spacing
  - locking features
  - installation torques and processes
  - criteria for design and analysis
- Educate everyone involved.

**Don't simply give everyone a standard, a set of criteria, or a manual.  
For standards and criteria to be effective, engineers and technicians  
must understand the reasons for them and feel ownership.**

## 2. Screw Threads: Evolution and Important Characteristics

- History of Screw Threads
- Rolled vs. Cut Threads
- Thread-form Features and Compatibility
- Tensile Stress Area
- Fine Threads vs. Coarse Threads



Permission is granted by Instar for anyone to freely copy, distribute, and print this material, but only in its unaltered form. This section may be separately copied or printed, but only in its entirety, including this page and with headers and footers intact. Unaltered individual figures and tables and portions of text may be copied or used, but only with text in quotes and with the following statement "Source: Design and Analysis of Bolted Joints (DABJ) course book, Thomas P. Sarafin, Instar Engineering and Consulting, Inc. Reproduced with permission." The date of last revision also should be included in the reference. If you have questions, contact [tom.sarafin@instarengineering.com](mailto:tom.sarafin@instarengineering.com).

## Early History of Screw Threads

- First use of screw threads was over 2000 years ago, but it's not clear when and by whom.
  - Commonly attributed to Archimedes circa 250 BC to lift irrigation water.
  - But some sources claim that screw threads were used around 400 BC in presses for olives and grapes.
- The first known use of threaded fasteners was in Germany, in the 15<sup>th</sup> century, by Johann Gutenberg for joints in his printing presses. Screws then started to be used in German-made clocks.
- In 1568, Jacques Besson in France invented the first screw-cutting lathe.
- At the start of the Industrial Revolution in the late 1700's, screw-cutting lathes were greatly improved for precision, especially by Henry Maudslay in 1797, and screws started to be mass produced in England.

**Use of threaded fasteners greatly increased with mass production, but fasteners weren't interchangeable because thread dimensions were not standardized.**

History summarized here and on the following pages was compiled from Refs. 14, 43 – 45, and 51.

## Initial Standardization of Thread Forms

Screw threads were not formally standardized until the mid 1800's. Two standards arose:

- **Whitworth Thread** in England, proposed by Sir Joseph Whitworth in 1841 and adopted by England in the 1860's (55° thread angle).
- **American National Thread** (a.k.a. **United States Standard Thread**), proposed by William Sellers in 1864, and adopted soon afterwards by the U.S. (60° thread angle and easier for machinists to produce than the Whitworth Thread).

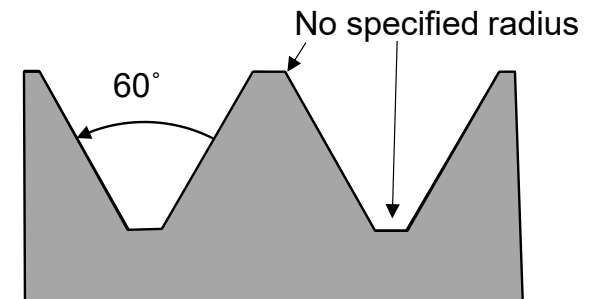
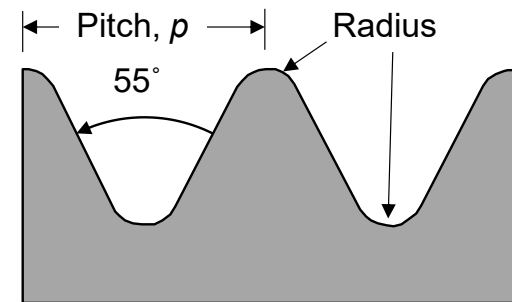

## The Unified (UN) Thread

- Problems with fastener interchangeability during World War I sparked interest in an international standard for threads, but the goal had not been achieved before the onset of World War II.
- In 1949, in response to continued problems with fastener interchangeability during World War II, the U.S., Great Britain, and Canada agreed upon the inch-based **Unified (UN)** thread form.
  - Very similar to the American National Thread, with a  $60^\circ$  thread angle.
  - No specified **root radius** (radius between threads)
- In the late 1800's, the metric thread form began to evolve and settled on a  $60^\circ$  thread angle by the end of that century.
  - Originally, the proposed standard metric (**M**) thread was the same geometrically as the UN thread, without a minimum root radius.
  - But, when the M thread form was standardized in 1969, it included a minimum root radius.

**Metric threads are now standard everywhere ... except in the U.S.**

**We still have problems with fastener interchangeability!**

## Basic Thread Profile for UN and Metric External Threads

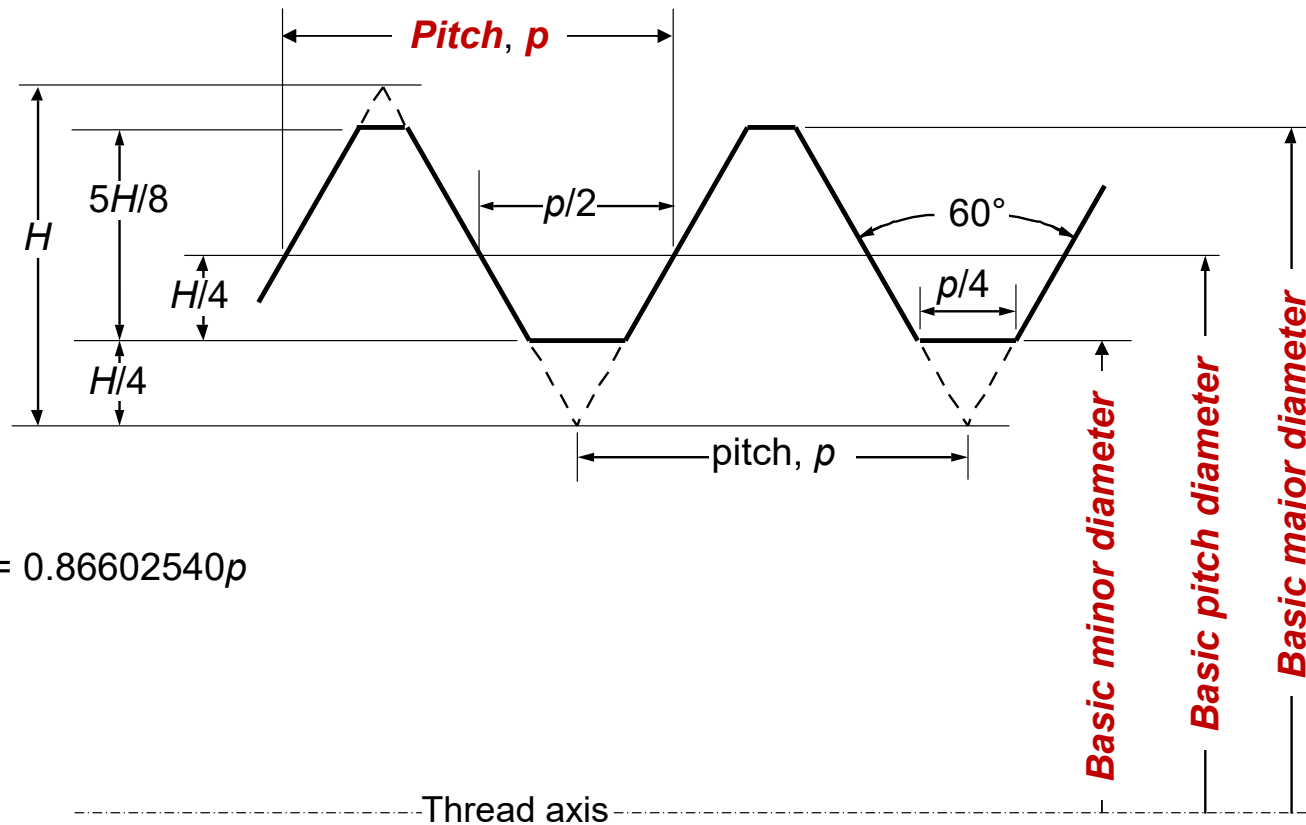

$$H = 0.86602540p$$

Ref. 8 (ASME B1.1) and 47 (ASME B1.13M)

## Thread Improvements for Fatigue Resistance

In the 1950's, two inch-based thread forms were developed to improve fatigue life:

- **UNR** requires a minimum root radius.
- **UNJ** (developed shortly after UNR) requires a larger (full) root radius.
  - Dimensions controlled by SAE-AS8879 (Ref. 5, formerly MIL-S-8879)
  - Metric counterpart designated **MJ**

It was also discovered that bolt threads that are produced by cold rolling (pressure between dies) are more fatigue resistant than cut threads (better grain structure and residual compressive stress at thread root).

- **But the benefits are significant only if threads are rolled after the heat treatment that increases material strength to required levels.**
- Rolling threads after heat treatment also slightly increases a bolt's tensile strength.

Nearly all procured fasteners have rolled threads nowadays.

- Thread-rolling machines are expensive, but the recurring cost of thread rolling is much lower than it is for thread cutting.
- But, unless otherwise required, threads are typically rolled before heat treatment, when the material is weaker, thus not providing the full benefits.

## Thread Cutting Vs. Thread Rolling

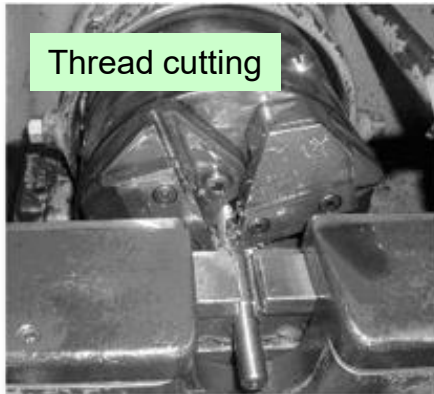

Thread cutting

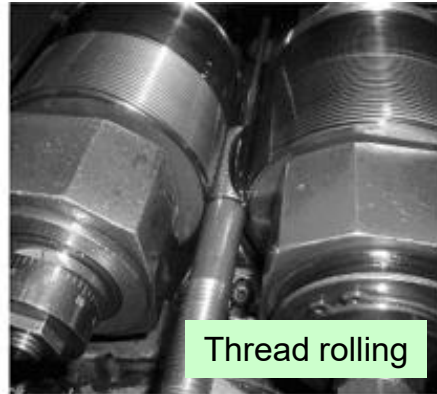

Thread rolling

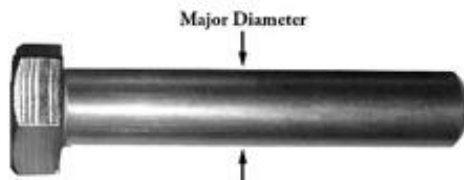
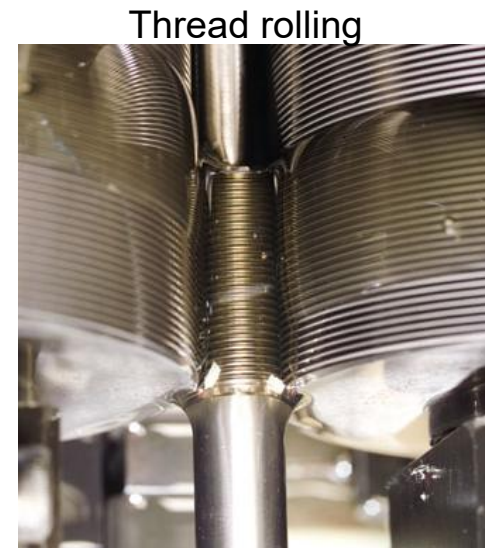

Image credit: Fastenal.com



Thread rolling

Image credit: Horstengineering.com

### Material grain comparison



Cut

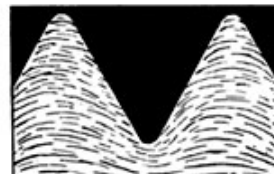

Rolled after heat treatment

(images from Horstengineering.com)

The dies used for thread rolling have a radius, and rolled UN threads typically meet the requirements for UNR (Ref. Fastenal.com).

## Comparison of External (bolt) Thread Forms

**UN**

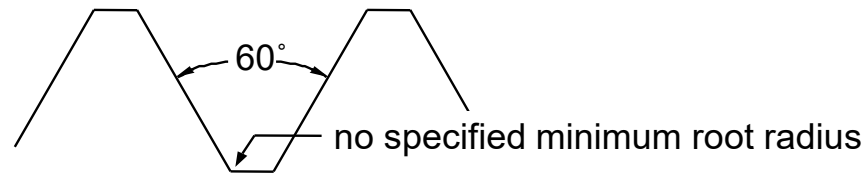

**UNR and M threads**

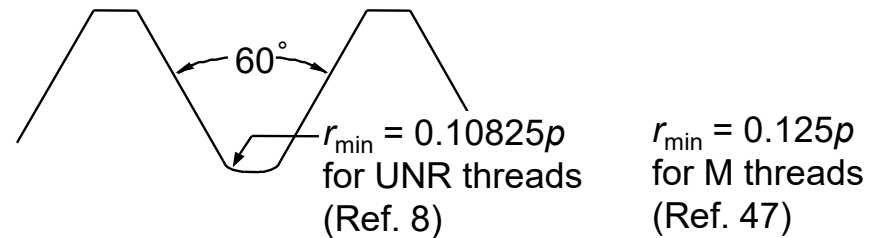

For critical bolts in flight-hardware tension joints, use UNJ threads that are formed by rolling after heat treatment.

**UNJ**

**(analogous to MJ)**

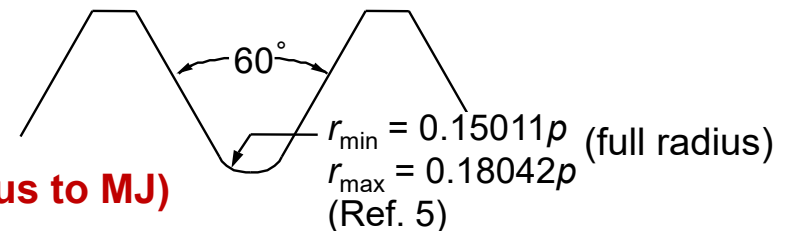

Ref. 5, SAE AS8879 controls the dimensions of the UNJ thread form but does not specify that the threads must be rolled after heat treatment.

**A larger root radius can increase strength as well as fatigue life.**

## Requirements for Fasteners Commonly Used in Flight Hardware

Bolt Spec	Description	Procurement Spec	In bolt spec		Typically in procurement spec		
			UNR	UNJ	Threads Must Be Rolled	Threads Must Be Rolled After Heat Treatment	Head-Shank Fillet Must Be Cold Worked After Heat Treatment
NAS1351, NAS1352	Socket head cap screw	FF-S-86	X		X		
NAS6703 - 6720	160 ksi A-286, hex head	NAS4003		X	X	X	X, except for NAS6703 (#10)
NAS1953 - 1970	180 ksi A-286 and Titanium	NAS4003 & 4004		X	X	X	X
NAS6403-6420	Titanium	NAS4004		X	X	X	X, except for NAS6403 (#10)
NASM14181	220 ksi Inconel 718	NAS4008		X	X	X	X

**Read the specs. Know your hardware!**

Important for fatigue life under cyclic tensile loading

## Example Call-out for Unified Threads

Major diameter (as a decimal or fraction of an inch) or screw number (e.g., 10 for a 0.190 major dia.)

0.2500-28 UNJF-3A

Number of threads per inch,  $n$

Thread form

F for fine thread  
C for coarse thread

- C has fewer threads per inch than F and a deeper cut

A for external thread (bolt)  
B for internal thread (nut, tapped hole, threaded insert)

Thread class:

- Class 3, which has smaller dimensional tolerances than Class 2, is commonly used for flight hardware.
- AS8879 threads are UNJ Class 3.

Ref. 8, ASME B1.1, Sec. 6

## Example Call-out for Metric Threads

Ref 6, ANSI/ASME Y14.6

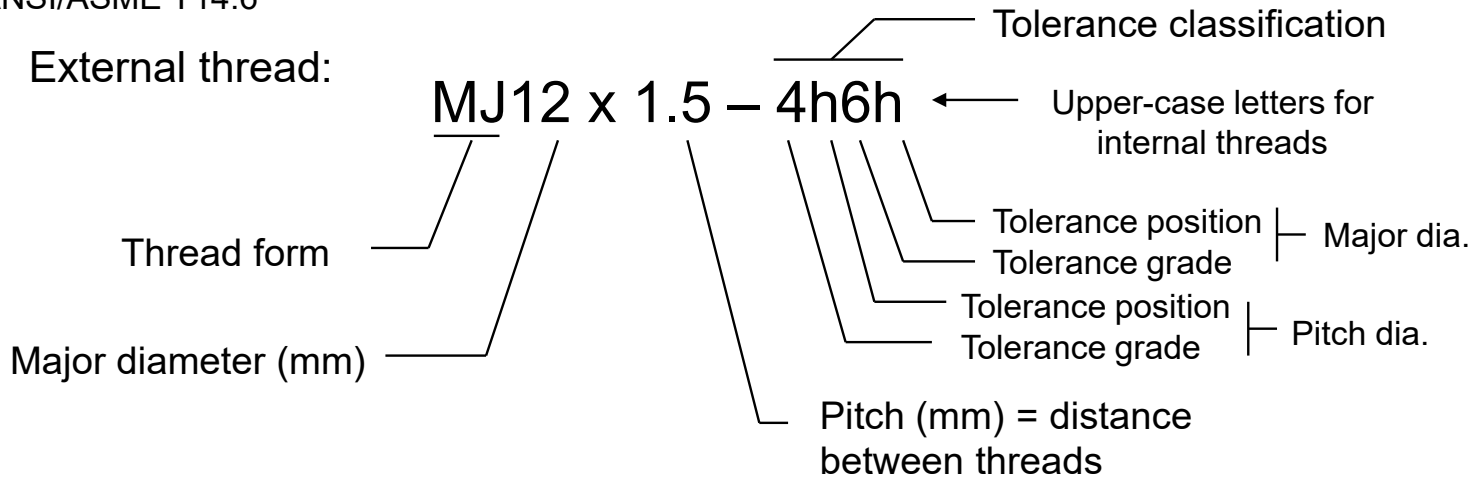

### Tolerance Classifications (external threads):

- Tolerance grade—a number from 3 through 9 (4 – 8 for internal threads), with lower numbers indicating tighter tolerances
- Tolerance position—a letter from “a” through “h”, indicating placement of tolerance zone with respect to the basic thread form, with “h” indicating zero deviation

	<u>External Thread</u>	<u>Internal Thread</u>	<u>Analogous UN Class</u>
Fine tolerance (MJ):	4h6h	4H5H	3A/3B (UNJ)
Medium tolerance (M):	6g	6H	2A/2B (UN)

## Make Sure the Thread Forms are Compatible!

Bolt threads		Nut, insert, or tapped threads			
External Thread	Internal Thread		External Thread	Internal Thread	
	UN	UNJ		M	MJ
UN	YES	YES	M	YES	YES
UNR	YES	YES	MJ	NO	YES
UNJ	NO	YES			

**These combinations may result in interference.**

**NASA-STD-5020B, Sec. 4.7.2: Mating threaded parts shall have compatible thread forms.**

*Examples of incompatible thread combinations are:*

- *Fine threads mated to coarse threads*
- *Inch-based threads mated to metric threads*
- *Mated threads with the same pitch and different nominal diameters*
- *External UNJ threads mated to UN internal threads*
- *External MJ threads mated to M internal threads*

## A Bolt's Tensile Strength is Based on Its Tensile Stress Area (Exceptions: flush-head fasteners and shear-type fasteners with thin heads)

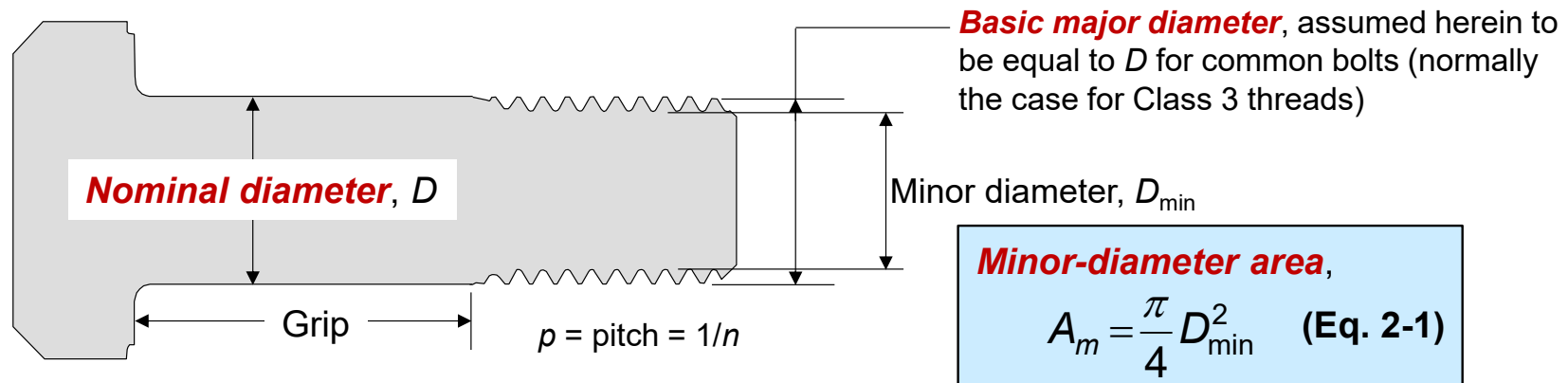

A bolt with a tension-type head has a higher tensile strength than is calculated by multiplying the allowable ultimate tensile stress,  $F_{tu}$ , by the minor-diameter area.

A larger **tensile stress area,  $A_t$** , is empirical. Expressions for tensile stress area are provided on the following page.

**Allowable ultimate tensile loads for most aerospace bolts are listed in the fastener specifications. Unless the bolt is meant mainly for shear loading and has a thin head, the specified tensile strength is typically equal to the product  $F_{tu}A_t$ .**

**Note: The allowable ultimate tensile load for a fastening system,  $P_{tu\text{-allow}}$ , is the lesser of the allowable load for the bolt, the specified load rating for the nut or insert, and the insert pull-out strength, as applicable.**

## Equations for Tensile Stress Area Based on Thread Form

Inch-based threads:

Thread form:	UN and UNR	UNJ*
$A_t =$	$\frac{\pi}{4} (D - 0.9743p)^2$ <p><b>(Eq. 2-2)</b> (ref. 8 Appendix B)</p>	$\frac{\pi}{4} (D - 0.6495p)^2$ <p><b>(Eq. 2-3)</b> (ref. 24 combined with ref. 5 Table 9)</p>

Based on maximum pitch diameter,  $d_{pe,max} = D - 0.649519p$

Metric threads:

Thread form:	M	MJ*
$A_t =$	$\frac{\pi}{4} (D - 0.9382p)^2$ <p><b>(Eq. 2-4)</b> (ref. 47 Appendix B)</p>	$\frac{\pi}{4} d_{e-minor,max}^2 \left[ 2 - \left( \frac{d_{e-minor,max}}{d_{pe,max}} \right)^2 \right]$ <p><b>(Eq. 2-5)</b> (ref. 25)</p>

\*if threads are rolled after heat treatment

$D$  = basic major diameter (nominal diameter)

$p$  = pitch

$d_{pe,max}$  = max. pitch diameter of external (bolt) threads

$d_{e-minor,max}$  = max. minor diameter of external threads

**Table 2-1. Design Data for UN, UNR, and UNJ External Threads (units: in.)**

Size	Nominal (basic major) dia., $D$	Full body shear area, $A_s$	Fine threads					Coarse threads				
			Threads per inch, $n$	Minor-dia. area, $A_m$		Tensile stress area, $A_t$		Threads per inch, $n$	Minor-dia. area, $A_m$		Tensile stress area, $A_t$	
				UN & UNR	UNJ	UN & UNR	UNJ*		UN & UNR	UNJ	UN & UNR	UNJ*
#2	0.0860	0.00581	64	0.00339	0.00338	0.00393	0.00452	56	0.00310	0.00309	0.00370	0.00435
#4	0.112	0.00985	48	0.00566	0.00566	0.00660	0.00762	40	0.00496	0.00500	0.00603	0.00720
#6	0.138	0.01496	40	0.00874	0.00877	0.01014	0.01164	32	0.00745	0.00753	0.00909	0.01088
#8	0.164	0.0211	36	0.01285	0.01291	0.01473	0.01673	32	0.01196	0.01204	0.01401	0.01622
#10	0.190	0.0284	32	0.0175	0.01760	0.0200	0.0226	24	0.01450	0.01470	0.01753	0.0209
1/4	0.250	0.0491	28	0.0326	0.0327	0.0364	0.0404	20	0.0269	0.0273	0.0318	0.0372
5/16	0.3125	0.0767	24	0.0524	0.0527	0.0581	0.0640	18	0.0454	0.0460	0.0524	0.0600
3/8	0.375	0.1104	24	0.0809	0.0811	0.0878	0.0951	16	0.0678	0.0687	0.0775	0.0878
7/16	0.4375	0.1503	20	0.1090	0.1096	0.1187	0.1288	14	0.0933	0.0947	0.1063	0.1201
1/2	0.500	0.1963	20	0.1486	0.1493	0.1600	0.1717	13	0.1257	0.1274	0.1419	0.1591
9/16	0.5625	0.249	18	0.189	0.1898	0.203	0.218	12	0.1620	0.1643	0.1819	0.203
5/8	0.625	0.307	18	0.240	0.241	0.256	0.272	11	0.202	0.205	0.226	0.252
3/4	0.750	0.442	16	0.351	0.353	0.373	0.395	10	0.302	0.306	0.334	0.369
7/8	0.875	0.601	14	0.480	0.483	0.509	0.539	9	0.419	0.425	0.462	0.506
1	1.000	0.785	12	0.625	0.628	0.663	0.703	8	0.551	0.558	0.606	0.663

$$A_s = \frac{\pi D^2}{4}$$

Per Tables 6 and 7 of Ref. 8

Per Eq. 2-2  
Based on minimum minor diameter specified in Ref. 5

Per Eq. 2-3

\*Provided  $A_t$  values for UNJ apply only if threads are rolled after heat treatment.

Caution: I would not use Tables 8.1.5(b<sub>1</sub> and b<sub>2</sub>) in the MMPDS (Ref. 2b) for either “Minimum Minor Area” or “Ultimate Tensile Strength”. They don’t agree with the above data and references.

## Fine Threads or Coarse Threads: Which Should We Use?

Fine threads are used more extensively for flight hardware.

- Greater tensile stress area; bolts with fine threads are stronger in tension
- Better for maintaining preload (smaller helical angle of thread)
- Greater preload for a given installation torque
- Better for fine adjustment
- Easier to tap in hard materials

But, for many applications, coarse threads can be a better choice (e.g., ground support equipment).

- Easier to assemble and more robust
  - less likely to cross-thread (a major reason why many aerospace-grade fasteners smaller than #10 are available with coarse threads only)
  - less sensitive to imperfections and contaminants
  - fewer turns of the wrench needed
- But more likely to loosen (lose preload) under cyclic loading

## Key Points from Sec. 2

- For critical bolts in flight vehicles, if subject to high cyclic tensile loads and fatigue is of concern, select fasteners with the UNJ or MJ thread form.
  - And make sure threads are rolled after heat treatment.
- Make sure mating threads are compatible.
  - Avoid UN or M internal threads combined with UNJ or MJ external threads.
- Read and get to know the specifications for the selected fastening system hardware.
- Take advantage of the empirical tensile stress area when computing strength.
- Keep in mind the pros and cons of coarse vs. fine threads.

### **3. Developing a Concept for the Joint**

- General Types of Joints and Fasteners
- Configuring the Joint
- Designing a Stiff Joint
- Shear Clips and Tension Clips
- Avoiding Problems with Fixed Fasteners

Permission is granted by Instar for anyone to freely copy, distribute, and print this material, but only in its unaltered form. This section may be separately copied or printed, but only in its entirety, including this page and with headers and footers intact. Unaltered individual figures and tables and portions of text may be copied or used, but only with text in quotes and with the following statement "Source: Design and Analysis of Bolted Joints (DABJ) course book, Thomas P. Sarafin, Instar Engineering and Consulting, Inc. Reproduced with permission." The date of last revision also should be included in the reference. If you have questions, contact [tom.sarafin@instarengineering.com](mailto:tom.sarafin@instarengineering.com).

## Orientation of the Bolt Relative to the Applied Load

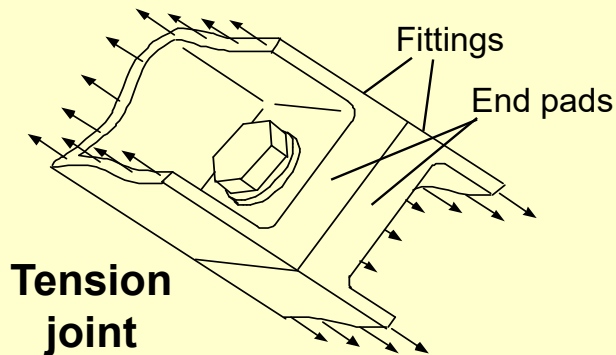

- Performance not affected much by clearance holes for bolts and metal shims (spacers) between fittings
- Works well with nuts, tapped holes, and threaded inserts
- Hard to avoid nonlinear stiffness (tension vs. compression)
- For high strength, stiffness, and fatigue life, ...
  - tuck fasteners near tension walls,
  - use thick end pads or flanges,
  - and ensure high preload

### Shear joint

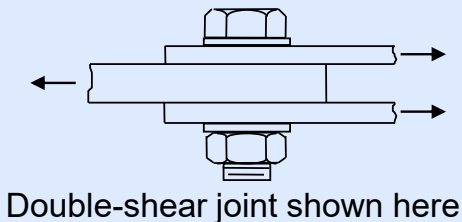

- Usually weighs less than a tension joint for equal ultimate strength
- Can weigh more than a tension joint when designed not to slip (friction joint) within clearance holes; use of features such as interference-fit shear pins can be effective but complicate assembly
- Double shear is preferred over single shear because load is divided over two shear planes in the bolt and the loading is symmetric
- Shims reduce joint strength (especially yield strength)

### Tension–shear joint

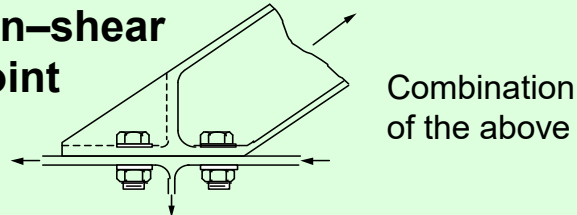

**We'll discuss most of the above points further in this section and in later sections of the course.**

## Floating Fasteners vs. Fixed Fasteners

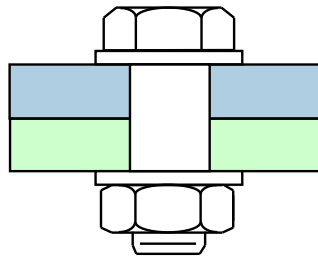

Through bolt with nut  
(**floating fastener**)

### Advantages

- Better for shear joints
  - Can keep threads out of the shear plane and out of bearing, thus increasing shear strength
  - Can match drill and ream holes to obtain a tight fit with the bolts

### Disadvantages

- More difficult to assemble
  - Requires wrench access from both sides
  - More parts to handle—and potentially drop

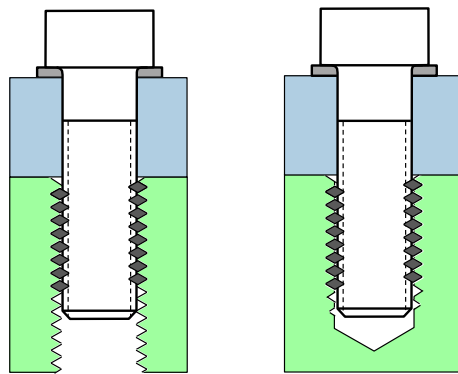

Through

Blind

Bolt into tapped hole or threaded insert (**fixed fastener**)

Nut plates discussed in Sec. 7

Often better than floating fasteners for tension joints:

- Easier to assemble:
  - Requires access from only one side
  - Fewer parts to handle
- Can tuck internal-wrenching fasteners closer to tension walls by avoiding need for wrench clearance for a nut

- Not good for shear unless friction carries the load
  - Threads in shear plane and in bearing
  - Large clearance holes to accommodate tolerances
- Can't visually inspect thread engagement
- Can bottom out in blind holes; use through holes unless there's a good reason to make them blind

## Two Specialty Fasteners for Shear Joints

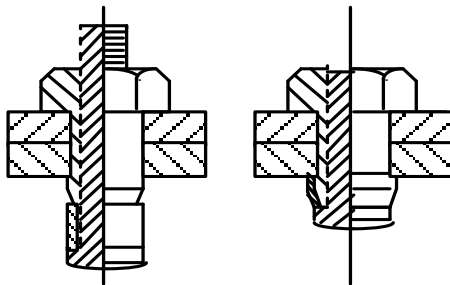

Blind fastener, internally threaded (“Jo-Bolt”)

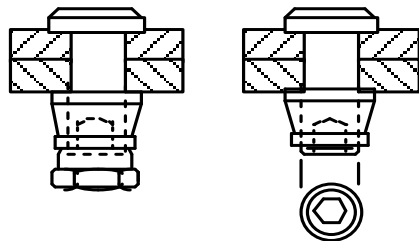

Image from <https://www.allaero.com/aircraft-parts/nas1670-0812>

- Advantages**
- Requires access from only one side
    - Used when there is no access to the other side and the joint member is too thin for a threaded insert
  - High shear strength

**Disadvantages & Limitations**

- Low tensile strength
- Low preload
- Not reusable; remove with drill



Threaded pin-riquet (Hi-Lok®)



Image from <https://sierrapacificsupply.com/products/hi-lok-fasteners/>

- Tightened from one side only
- Higher tensile strength and better fatigue properties than rivets
- Higher clamp load (preload) than with rivets
- High shear strength

- Lower tensile strength than standard bolt
- Low preload vs. standard bolt
- Need temporary access to both sides
- Not reusable

## Attaching to Sandwich Panels

Inserts held in place with potting material

- Drill out core
- Fill in around insert with potting material

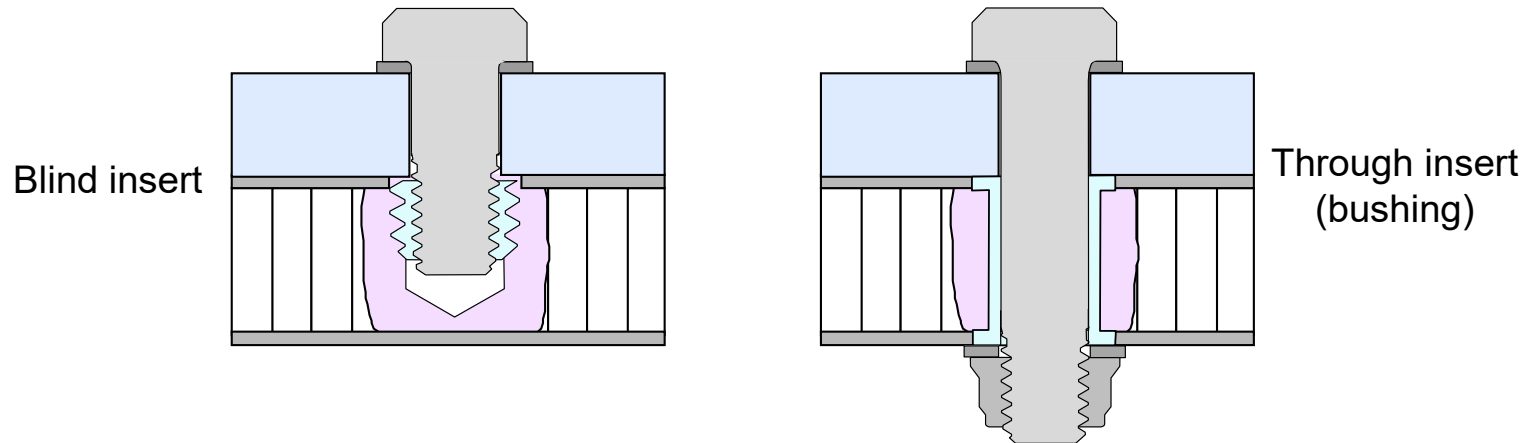

Pull-out strength is highly dependent on process variables

- Can be limited by adhesive failure, cohesive failure (shear of potting material), or core buckling
- Establish allowable loads based on development tests
- Proof testing often needed to establish confidence in each potted insert

## Through Insert in Sandwich, After Testing

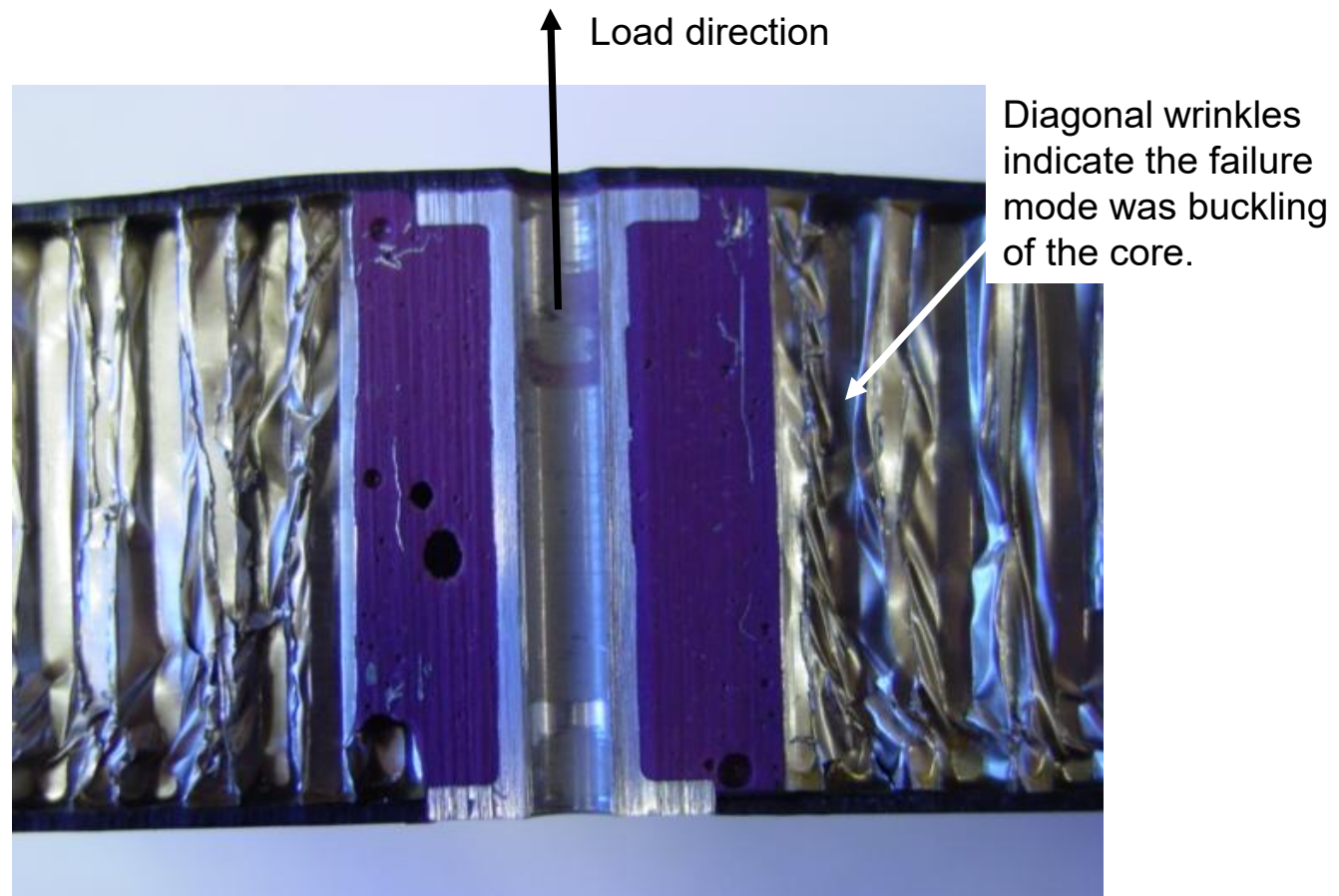

## Shear Pins

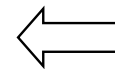
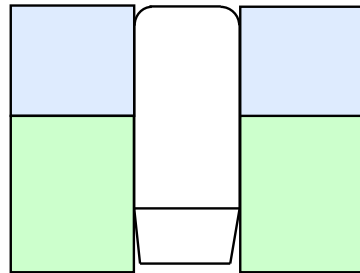

Used for maintaining alignment

Pressed into both parts (match-drilled and reamed undersize holes)

Used to carry shear loads in joints having bolts in tapped holes or threaded inserts (threads in shear plane)

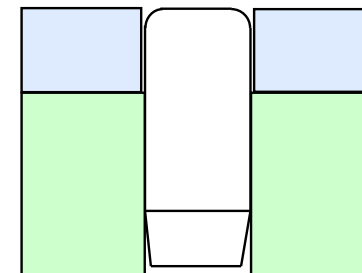
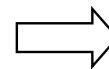

Pressed into reamed hole in one part, clearance hole in the other (can be drilled at part level, but clearance hole must be tight enough to ensure pin is loaded before bolts)

## When Configuring a Joint, Provide Direct Load Paths and Access for Fastener Installation

### For tensile loading:

- Tuck fasteners close to tension walls to minimize bending of the end pad or flange.
- Avoid significant prying on bolts by putting them next to two or more perpendicular tension walls.
- Leave room for the cutter radius and for the wrench or socket.
  - **Spotfacing** –using a tool to “face” (machine a smooth, flat surface) a part where the bolt head or washer sits; lets you tuck the fasteners closer to the tension wall.
- Try to make the centroid of the bolt pattern coincide with the line of action of applied load at the **faying surface** (contacting surface between joint members).

### For shear and moment:

- To avoid moment on the bolt pattern, align the applied shear load with the bolt-pattern centroid and the faying surface.
- When the joint must transfer a moment (bending or torsion), space the fasteners apart to achieve a large footprint.
- Design shear joints so that fasteners are in double shear, when possible.

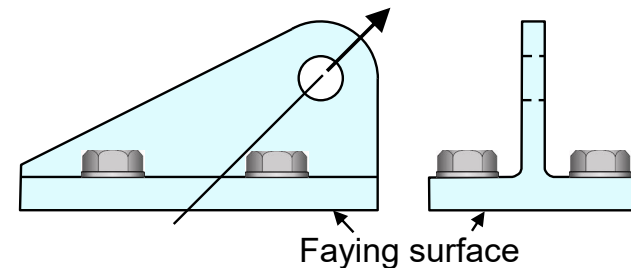

The bolted flange (end pad) will bend under the tensile load and pry on the bolts.

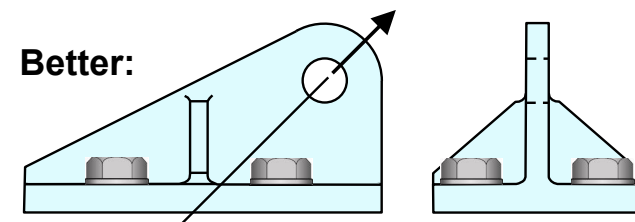

Adding gussets leads to negligible effects of prying when the critical failure mode is ductile and reduces shear and bending stresses in the end pad, thus allowing the end pad to be thinner.

## Joint Under Combined Tension and Moment

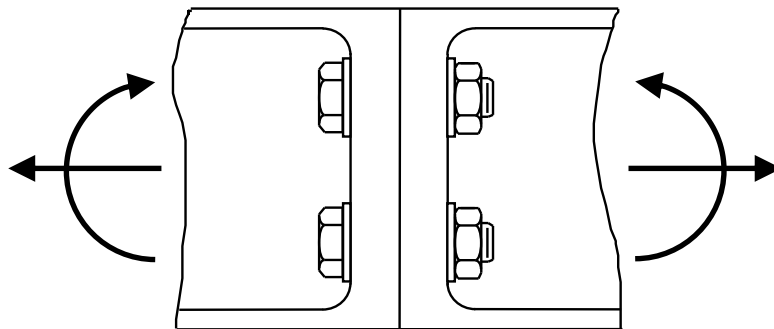

If the joint will see simultaneous tension and moment, space bolts apart so they can carry the moment as a tension-compression couple between the bolt locations.

For the joint shown at right, moment would have to be carried by prying on the bolt (heel and toe), but the applied tension acts to relieve compression at the heel. The result is a joint that has very low bending stiffness.

(See Example 4-g in the appendix to Section 4.)

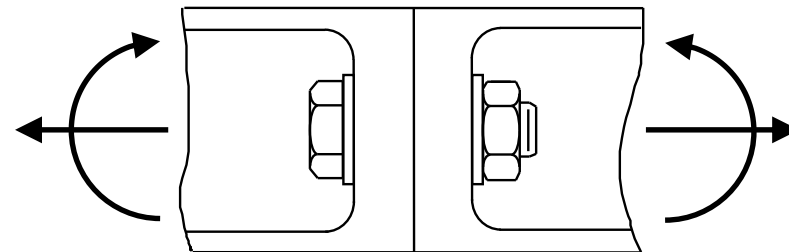

Avoid—use two bolts

## Goal: A Joint with High, Linear Stiffness but Ductile Failure

- High stiffness: keeps the structure’s natural frequencies high, which usually helps avoid high dynamic loads
- Linear relationship between load and displacement up to limit load: makes the structure more predictable with linear-elastic analysis (the vast majority of structural analyses, especially loads analysis)
- But we don’t want the joint to be linear all the way up to rupture.
  - If there’s an unanticipated high load or distribution of load (or an energy-limited load), plastic deformation allows loads to redistribute (or allows the joint to absorb energy) before anything ruptures.

Ductile failure: significant plastic deformation prior to rupture

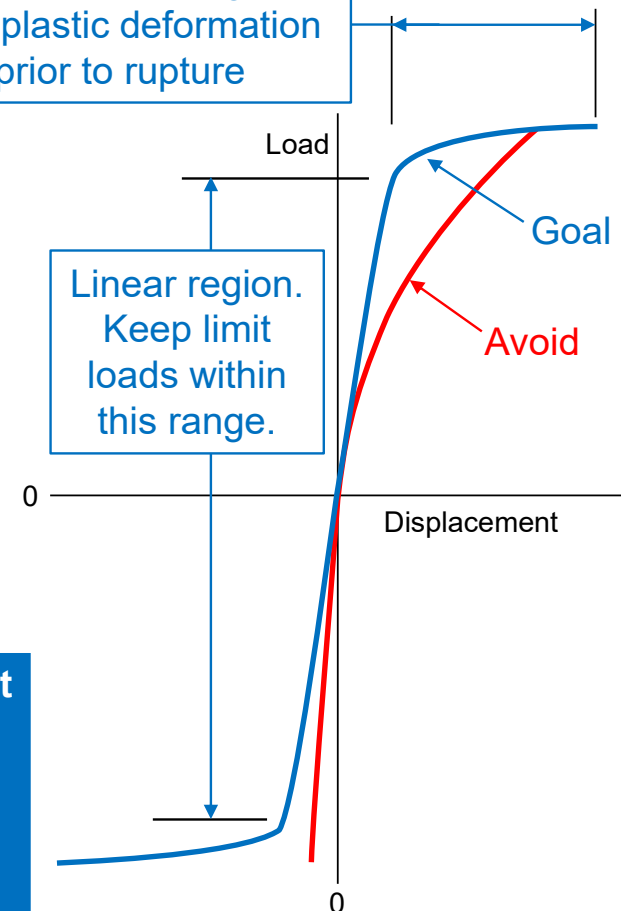

Designing to ensure that failure is ductile is important but often neglected, and is addressed multiple times in upcoming sections of this course.

The following pages address the goal of high, linear stiffness.

## Designing Stiff Tension Joints

Joint with high, relatively linear stiffness:

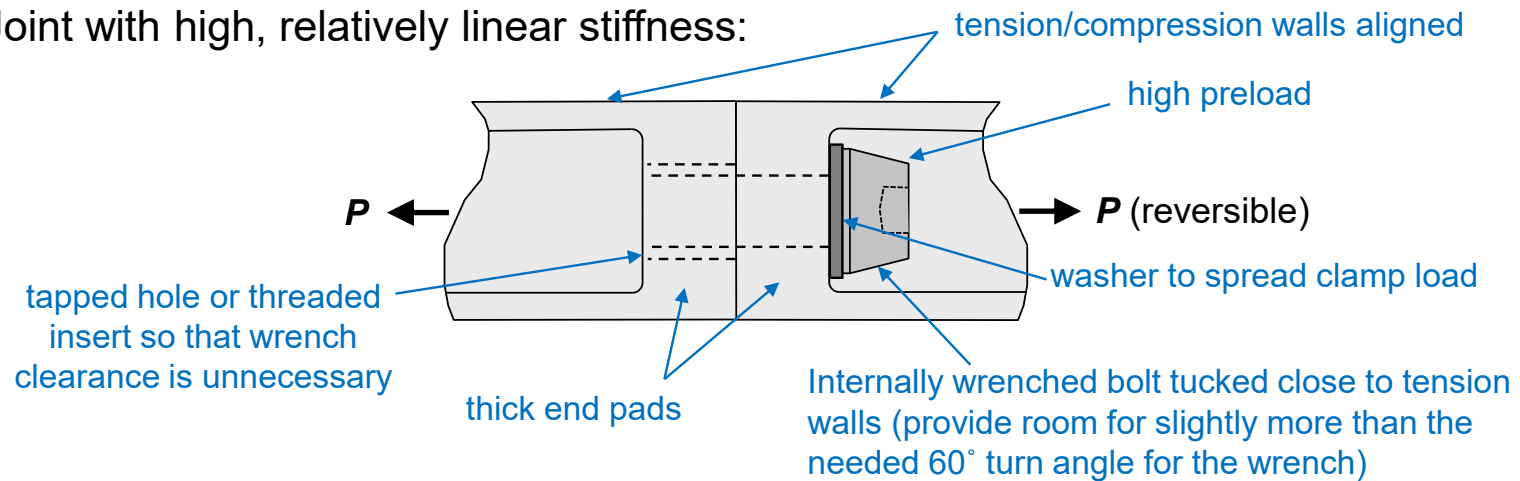

Joint that is stiff in compression and flexible in tension (avoid):

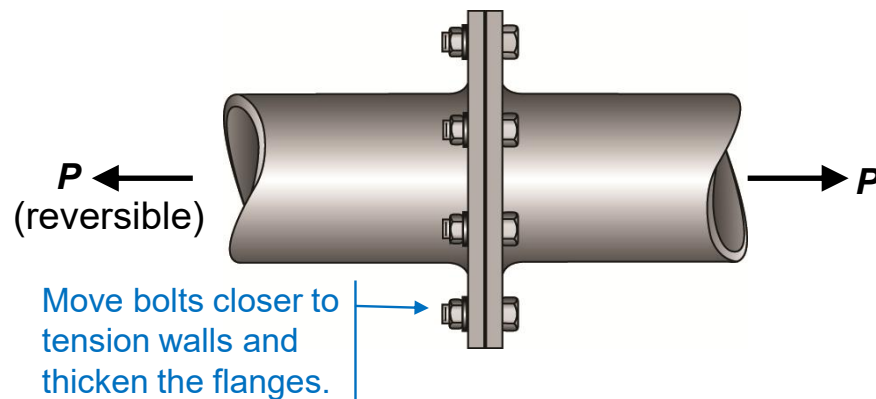

The thin flanges, with bolts far from the tension walls, will bend and pry on the bolts.

Nonlinear stiffness makes it difficult to predict dynamic response or load distribution within the structural assembly.

## Designing Stiff Shear Joints

Stiff shear joint:

(Single-shear joints are less stiff because (a) they tend to roll from eccentric loading and (b) bearing stress is less uniform through the plate thickness.)

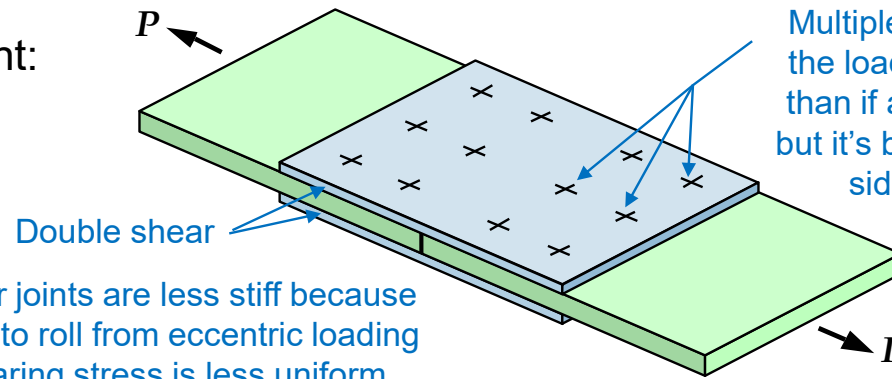

**For the stiffest joint, preload the fasteners high enough for load to transfer by friction.**

Flexible shear joint: (commonly used, but significant loss of stiffness)

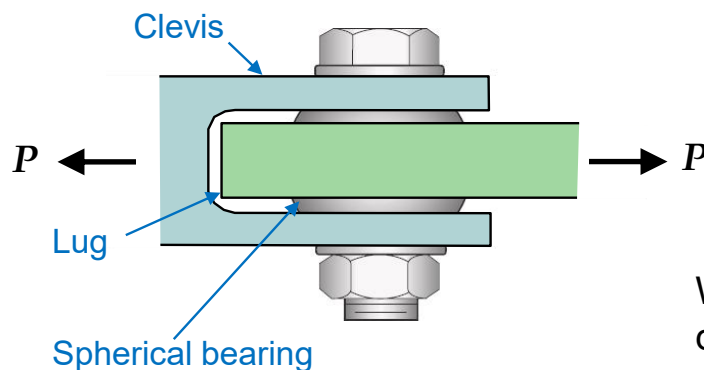

Each element adds a spring to the system:

- spherical bearing
- bolt (bending and shear)
- lug and clevis ears (tension and local bearing strain energy)

When using a joint like this in a stiffness-critical design, predict stiffness with a detailed finite element model and measure the joint's stiffness in test.

## What's Wrong with This Design?

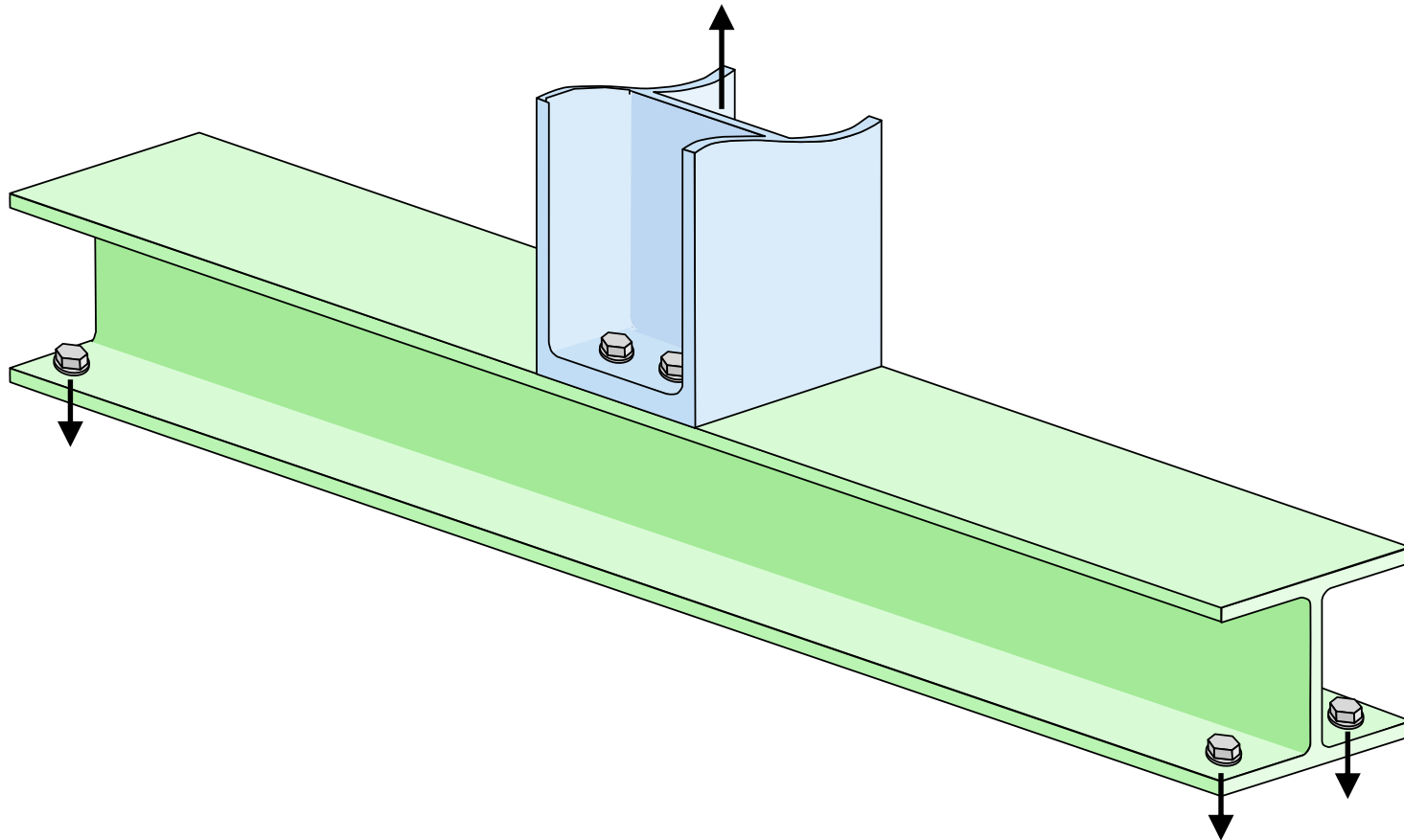

## Add Gussets to Reduce Flange Bending

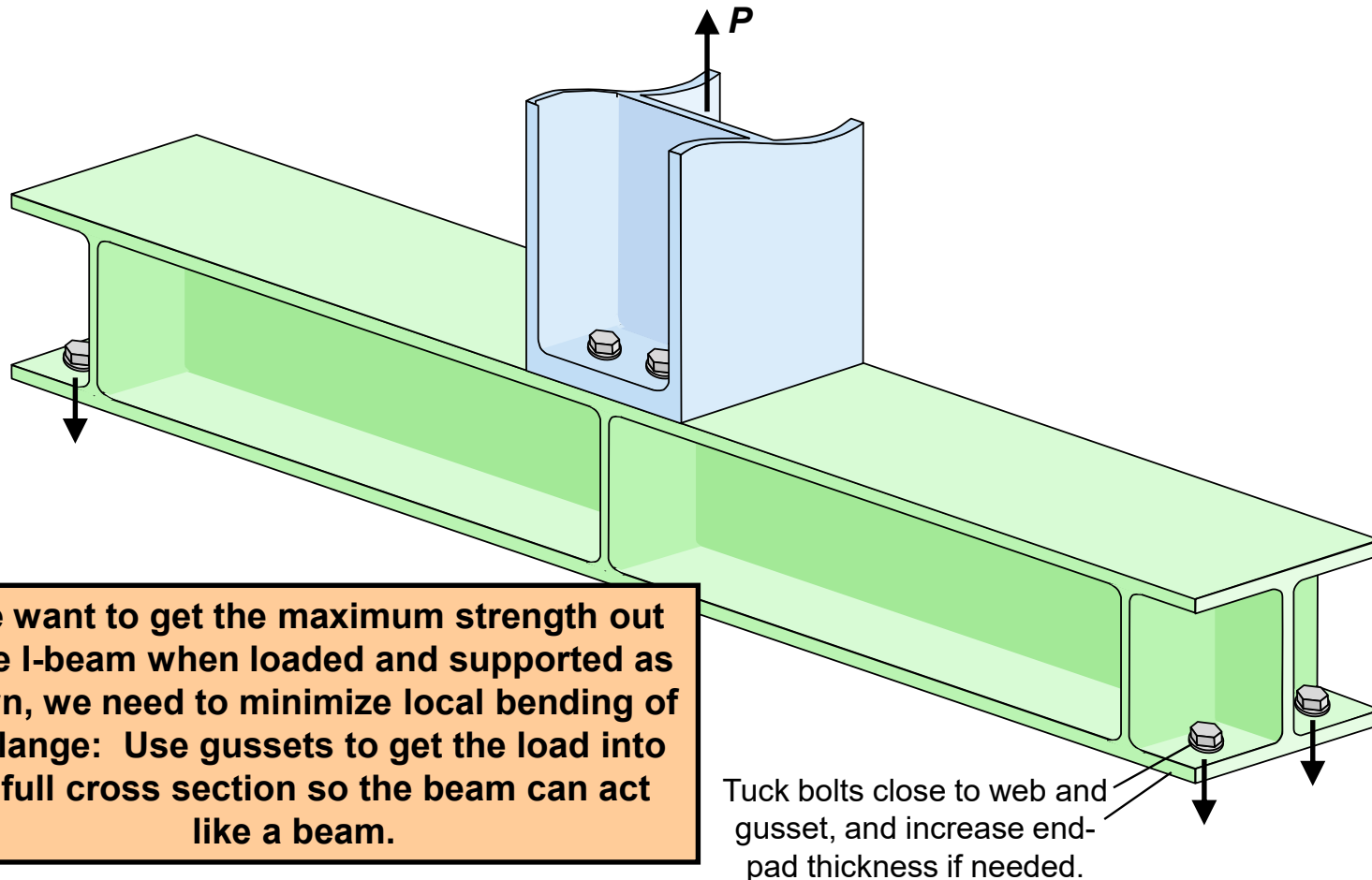

If we want to get the maximum strength out of the I-beam when loaded and supported as shown, we need to minimize local bending of the flange: Use gussets to get the load into the full cross section so the beam can act like a beam.

Tuck bolts close to web and gusset, and increase end-pad thickness if needed.

## What's Wrong with This Design?

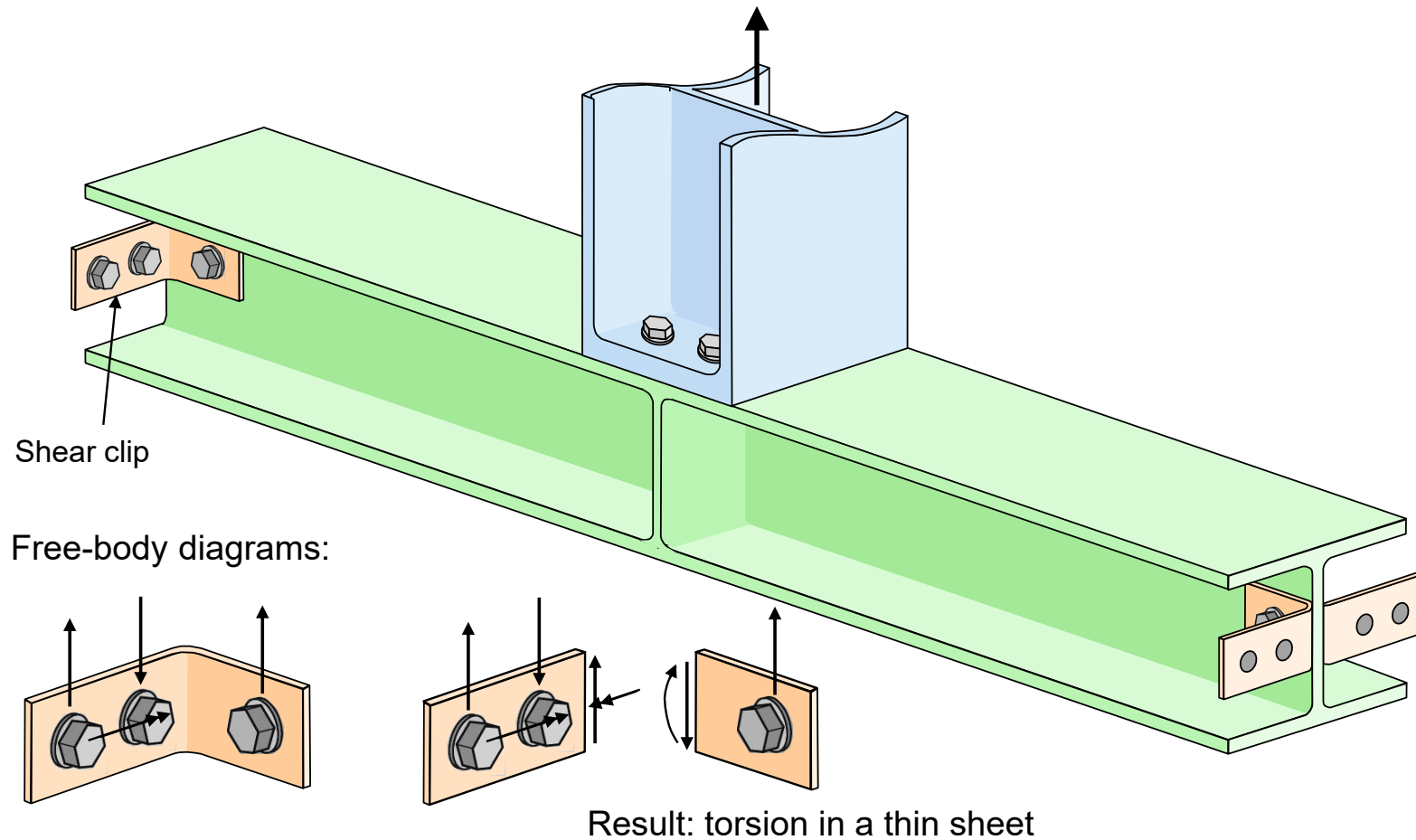

## Designing Shear Clips

Put two fasteners on each leg:

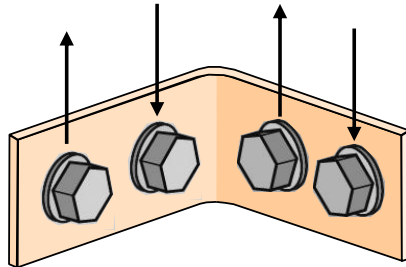

Pure shear, negligible moment at corner

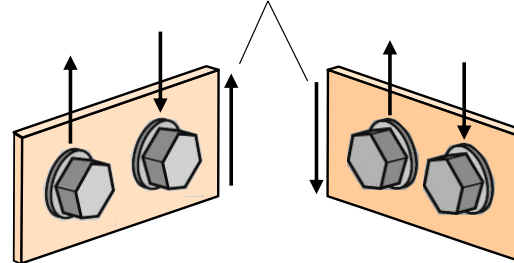

Result: The clip is able to transfer shear without torsion on either leg.

But don't put the bolts side by side.

A much better design:

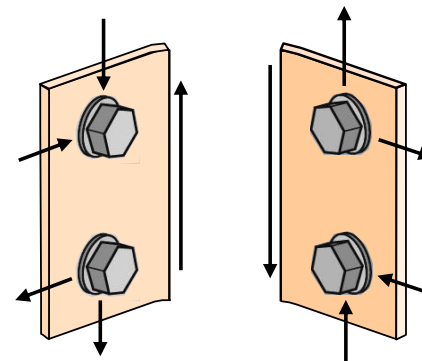
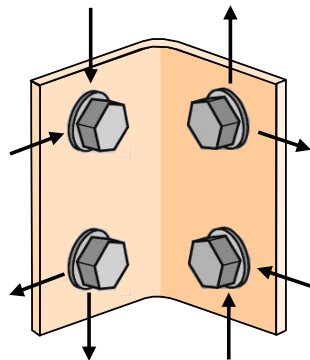

Result: Less peak resultant shear load on a fastener

We now have an efficient simply supported beam.

## Remember to Use a Second Bolt!



But I guess one bolt is better than none!

## Tension Clips

Because of prying, the fastener load is magnified.

$$P_t = P \left( \frac{a + b}{b} \right)$$

Three failure modes of concern:

- Bolt tension
- Bending of the clip near bolt
- Shear of clip near bolt head

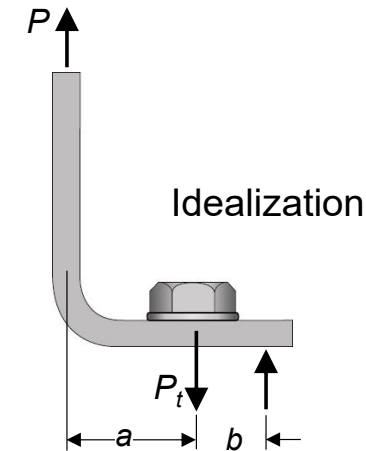

**Minimize dimension a.**

T-fittings also pry on bolts.

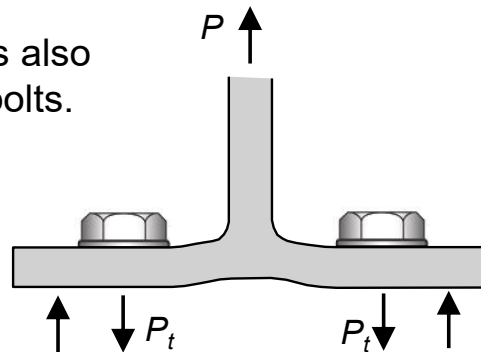

Note: Dimension  $b$  is hard to predict. If you don't have access to an empirical method\*, make a conservative assumption or use finite element analysis.

\*For an empirical method of determining an allowable yield load for a 2024 aluminum clip when using 1/4"-dia bolts, see Fig. D3.8 in Ref. 1 (Bruhn).

## Avoid Shear Loads in Fixed Fasteners

One assumption for a free-body diagram if the bolt must take the load:

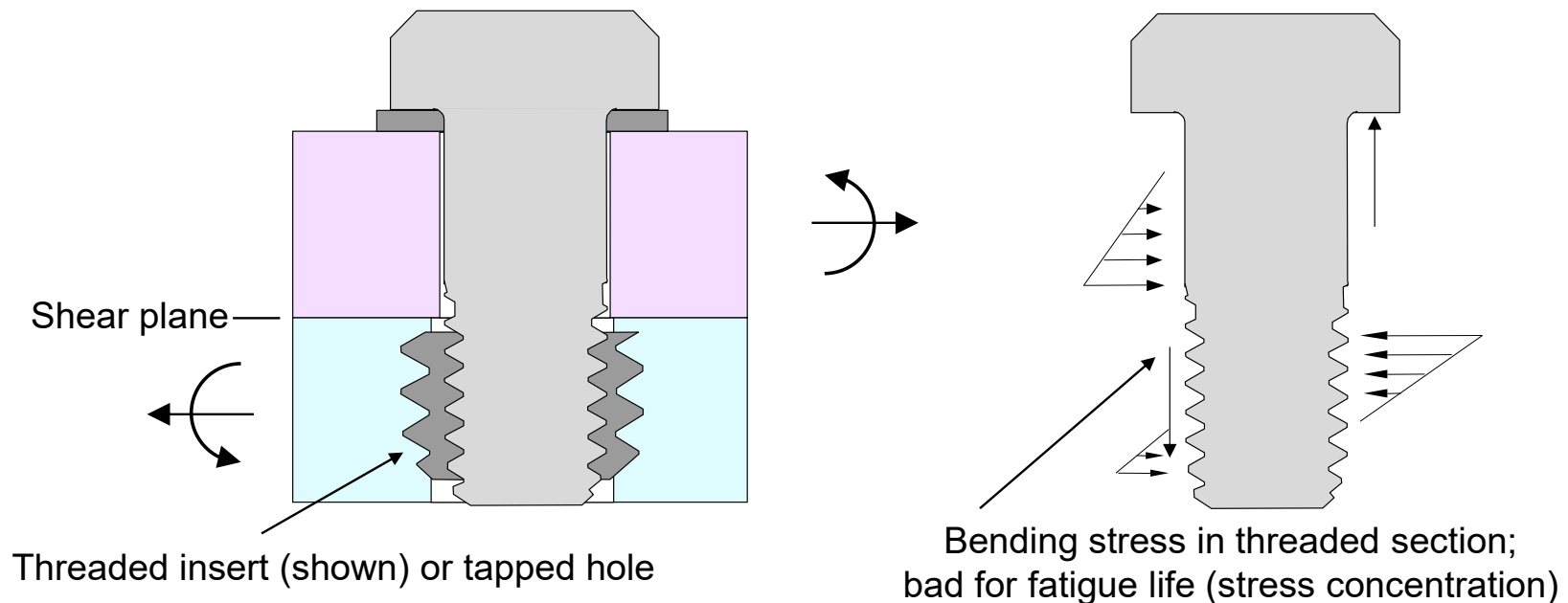

### Recommendation:

**If friction won't dependably carry the shear load when threads are in or near the shear plane (see Sec. 9 for joint-slip analysis), use a dedicated shear feature such as a shear pin or a shear lip to keep from loading the bolts.**

## Avoid Flush-head Fasteners with Tapped Holes or Threaded Inserts

Both features position the fastener

Any mismatch will cause the screw to bend as the head is torqued

Result: a weakened fastener; may break during installation or when under applied load



With a design such as this, plan on match drilling and countersinking at assembly, or use floating nut plates rather than tapped holes or inserts.

or counterbore instead

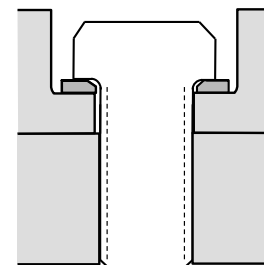

## Key Points from Sec. 3

- Consider requirements (e.g., stiffness and positional stability (alignment) when applicable), heritage (leverage past, successful designs), and ease of assembly when developing the concept for a joint.
- Provide direct load paths, aiming for high, linear stiffness.
  - But design to ensure ultimate failure is ductile. (See Secs. 4 & 5.)
- Trace load paths in your mind and use free-body diagrams to identify and avoid weak spots in the design.
- Avoid shear loads in fixed fasteners.
- Avoid flush-head fasteners in fixed applications.

## **4. Calculating Bolt Loads (applied loads acting on a bolt)**

- Important Cautions
- How a Preloaded Joint Carries Load
- Temporarily Ignoring Preload
- What About Friction as a Load Path?
- Common Assumptions and Their Limitations
- A Process for Calculating Bolt Loads in a Compact Joint
- Example Problem
- Appendix: More examples of calculating bolt loads

Permission is granted by Instar for anyone to freely copy, distribute, and print this material, but only in its unaltered form. This section may be separately copied or printed, but only in its entirety, including this page and with headers and footers intact. Unaltered individual figures and tables and portions of text may be copied or used, but only with text in quotes and with the following statement "Source: Design and Analysis of Bolted Joints (DABJ) course book, Thomas P. Sarafin, Instar Engineering and Consulting, Inc. Reproduced with permission." The date of last revision also should be included in the reference. If you have questions, contact [tom.sarafin@instarengineering.com](mailto:tom.sarafin@instarengineering.com).

## Important Cautions

Many of the assumptions used in the example problems in this section are traditional and can be safely used for assessing ultimate strength as long as the critical failure mode is ductile, meaning there would be significant plastic displacement before rupture.

- This section and Sec. 5 provide tips on how to ensure ductile failure for most bolted joints.

If rupture can occur without much plastic deformation, you should be more cautious when considering potential ...

- uneven distribution of load between fasteners
- local prying effects and bending stresses that traditional methods ignore for certain joints

Another important caution: Many of the assumptions used in this section can be safely used only for compact, symmetrical joints, where load distribution between fasteners is not significantly affected by relative stiffness.

**We'll discuss these topics further here and in Sec. 5.**

## Using Finite Element Analysis to Calculate Bolt Loads

- It's certainly convenient—but can be time consuming—to represent each bolt in the model and then calculate bolt loads with FEA.
  - And doing so is commonly practiced.
  - See Appendix A for thoughts on how to model bolted joints.
- Calculating bolt loads with FEA provides information that can be useful, especially for joints with bolts spread over a large area.
- But it often is overly penalizing.
  - Most FEA is linear-elastic, which directly applies to joints made of brittle materials.
  - Localized yielding in and near fasteners can allow loads to redistribute between bolts before rupture occurs in the joint—a benefit that we'd like to take advantage of in design but that is not accounted for in linear FEA.

**With good design practice, ensuring failure modes are ductile (see Sec. 5), we often can use the simple, traditional methods explored in this section and end up using bolts of smaller diameter than we would have used based on linear FEA.**

## When Predicting How Applied Loads Distribute Between Bolts, in Most Cases We Ignore the Effects of Preload

Idealization of a preloaded joint under applied tension

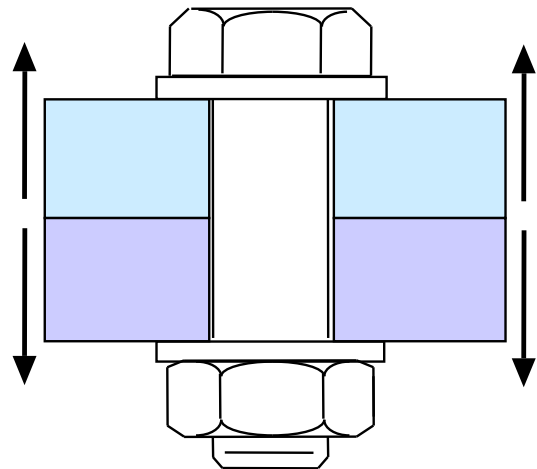

idealized  
as

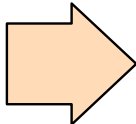
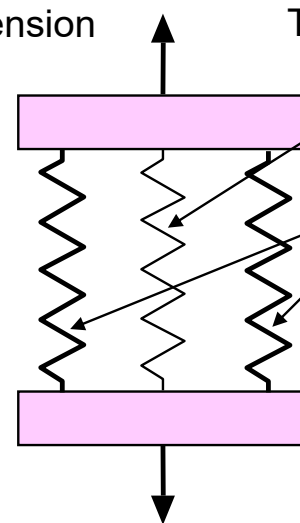
Two springs in parallel:

Spring representing the bolt, which is preloaded in tension

Annular spring representing fittings in compression (usually stiffer than the bolt)

Under applied tension, the bolt stretches further as its load increases, while the compressed load in the fittings decreases.

**In preliminary sizing—and often for detail design and analysis as well—keep it simple. Don't get embroiled in the mechanics idealized above. Estimate applied load per bolt, based on the assumption that each bolt provides a single load path. Then size the bolt based on design tables such as those developed in Appendix B.**

**We'll explore the mechanics of a preloaded joint in Sec. 8, and we'll see that, under applied tensile load, most well-designed all-metallic joints gap before anything breaks, which means preload does not affect the ultimate strength of such joints.**

## How a Preloaded Joint Carries Shear

Applied shear is initially carried by friction in a clamped joint:

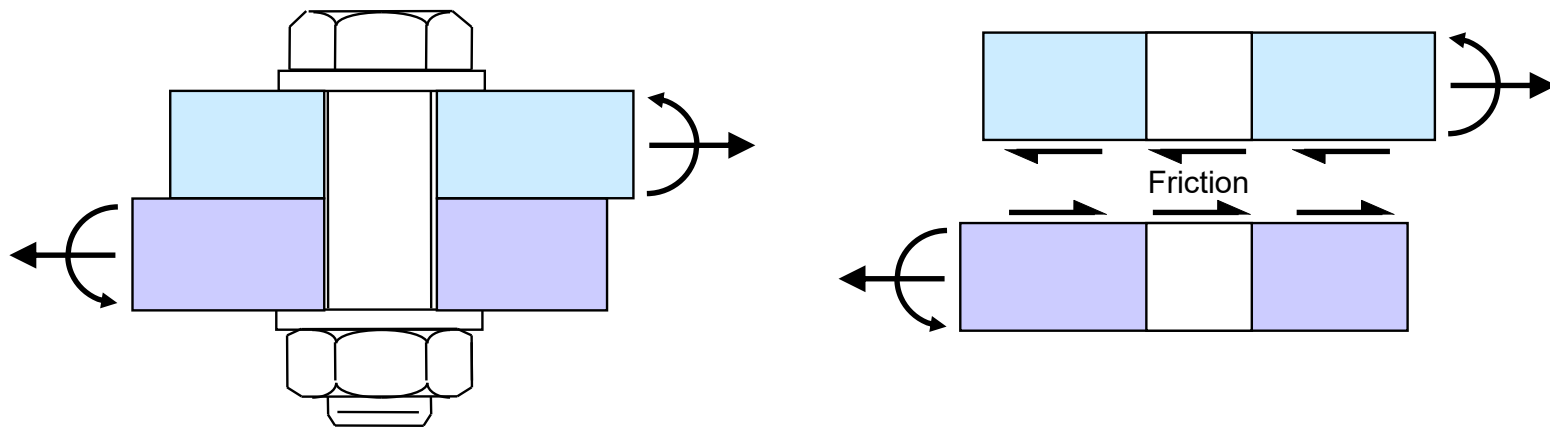

If the applied load overcomes friction, the joint slips within the clearance holes and loads up the bolt.

**When trying to determine how applied loads distribute between fasteners, we typically ignore friction and consider each fastener a discrete load path, same as we do for applied tension.**

**Section 9 addresses joint-slip analysis.**

## Can We Count on Friction as a Load Path?

It has been somewhat common practice in aerospace not to count on friction in stress analysis, i.e., show the joint can carry the design loads without friction.

- This used to be a requirement for most NASA programs—and still is for assessment of ultimate strength—and many other space programs as well.
- Traditional justification: Friction is not a dependable load path, especially in vibration or cyclic-loading environments.

However, friction is a desirable design feature.

- For the most dependable bolted shear joint, load is carried by friction rather than by shear in the bolts.
- This is especially true for cyclic, reversed shear loading. A joint slipping back and forth within clearance holes leads to
  - loss of preload (discussed in Sec. 7)
  - nonlinear stiffness and less predictable structural behavior
  - potential fatigue failure and fretting

**The NASA analysis standard from 1989 thru 2011, NSTS-08307 (Ref. 7), penalized shear joints for high preload. But tests show preload doesn't affect ultimate strength of shear joints (discussed in Sec. 9 herein).**

**The original NASA-STD-5020 team wanted to encourage good design practice—high preload for shear joints—and thus introduced criteria for taking advantage of friction.**

## Reliance on Friction per NASA-STD-5020B

- NASA-STD-5020B (Sec. 4.4.6) allows reliance on friction in analysis for alignment, yield strength, fatigue, and fracture mechanics.
  - As long as analysis shows a non-negative margin of safety on joint slip (see Sec. 9) using a conservative coefficient of friction in absence of approved test data:
    - 0.2 for cleaned, uncoated, non-lubricated metal surfaces; 0.1 otherwise  Reqmt 4.4.6b
  - If the slip margin is negative, no amount of friction can be relied upon.
- But not for ultimate strength. Rationale:
  - Tests (as addressed in Sec. 9) show that ultimate strength of a shear joint is the same, with and without preload. Plastic deformation apparently causes preload to relax, so there's no friction left to help carry the load.
  - The consequence of catastrophic failure is usually too high for us to count on having the preload we've calculated.
- Regardless of your program's criteria, be sure to account for friction if it's harmful.
  - Could friction loading cause failure somewhere else?
  - Could the friction load path change the structure's modes of vibration and thus affect the predicted launch loads?

# Calculating Bolt Loads is Often Based Simply on Statics

Example: Tension joint with 2 bolts

Case 1: Tensile applied load, with resultant load vector centered between bolts

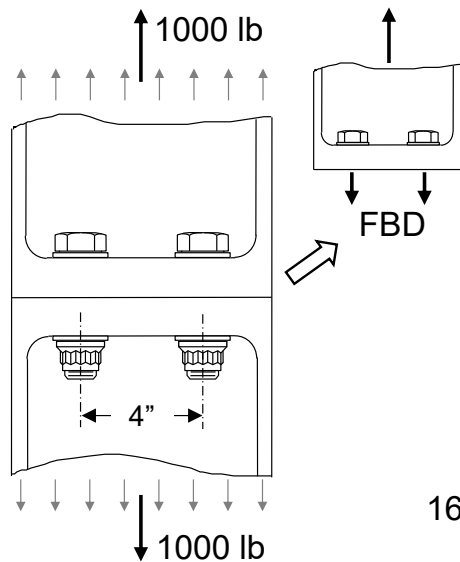

**What's the peak bolt load?**

Case 2: Applied moment

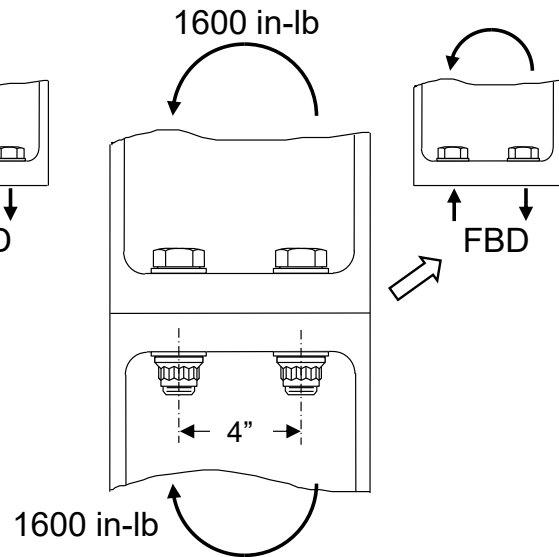

With loads carried only by the bolts,

**What's the peak bolt load?**

Case 3: Combined loads

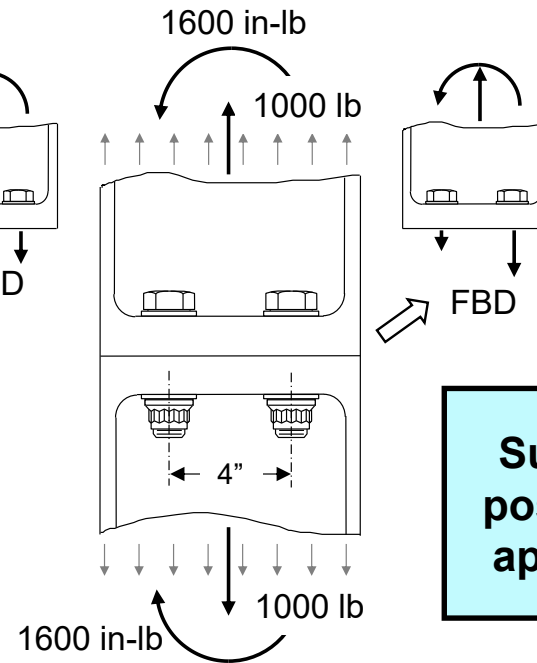

**What's the peak bolt load?**

**Superposition applies**

## What About Prying for the Joint on the Previous Page?

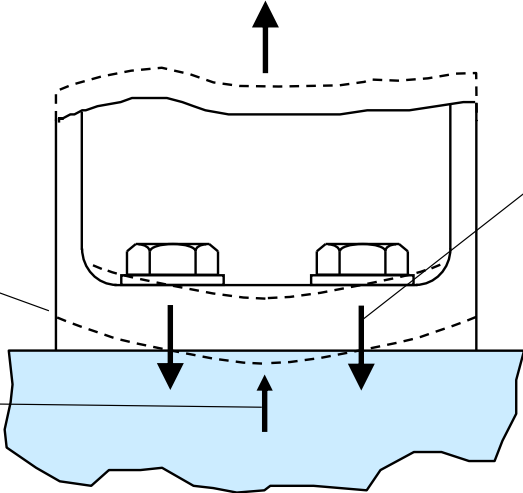
- 
1. Under applied load, the end pad wants to deform something like this (exaggerated)
  2. But it can't deform into the part below it, so a compressive force develops
  3. As a result, the bolt loads are somewhat higher than is calculated by dividing the applied load by number of bolts
  4. In addition, there will be some bending stress in the bolts

For ultimate strength analysis, we typically ignore these effects when the failure mode is ductile and two or more orthogonal tension walls back up the bolts (e.g., flange and web of the machined I-section shown above) because a small amount of yielding in the bolt relieves the prying and bending loads.

**For a joint like this, with two orthogonal tension walls, a fitting factor normally accounts for any associated reduction in strength when failure is ductile.**

We may ignore these effects for bolt fatigue analysis as well if the joint is preloaded not to gap at limit load because the clamp load path of the end pad lessens prying and bending.

## A Good Bolt is Made of a Ductile Material

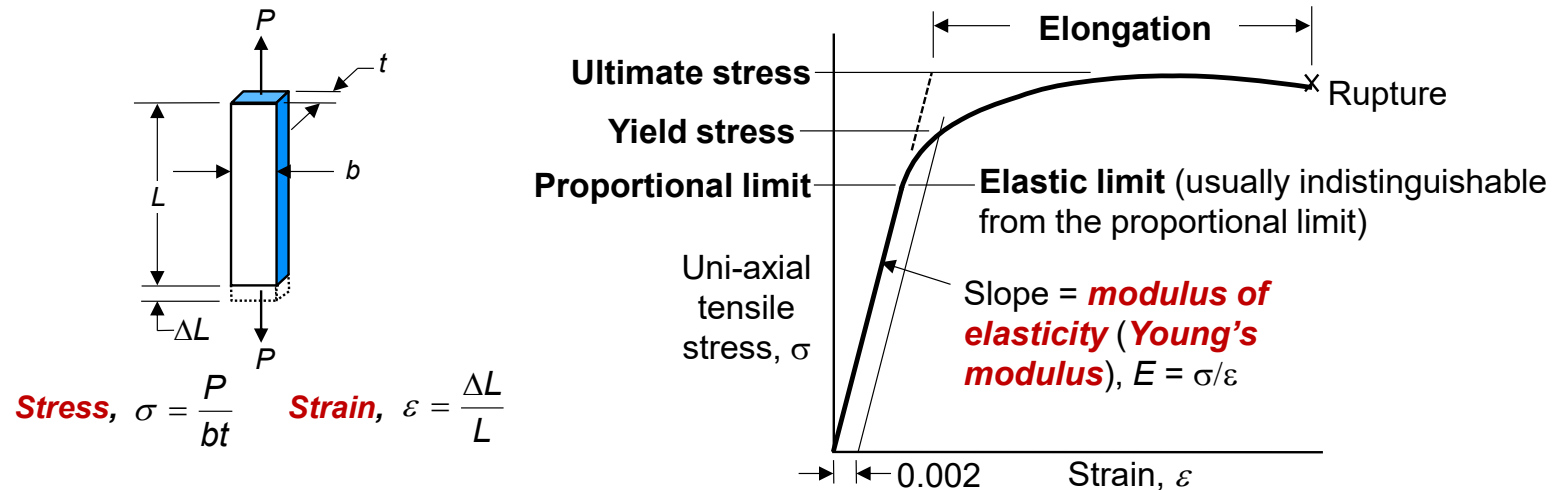

- Up to the **proportional limit**, a material acts like a linear-elastic spring.
- Stress above the **elastic limit** will cause permanent strain.
- For materials with stress-strain curves of the above shape, the tensile **yield stress** is traditionally defined as the stress that causes 0.2% permanent strain.
- The **ultimate stress** is the highest stress the material can withstand.
- **Elongation** (plastic strain to rupture) is a measure of the material's ductility.

**Where stress concentrates, such as in fastened joints, we want to use materials with good (> 10%) elongation so that loads and stresses can redistribute before rupture occurs.**

## Class Problem 4-1: Calculating Bolt Loads

Calculate (or conservatively estimate) the design ultimate tensile load in each of the two mounting bolts for use in strength assessment.

50 g design ultimate acceleration (not reversible), including any gravitational effects

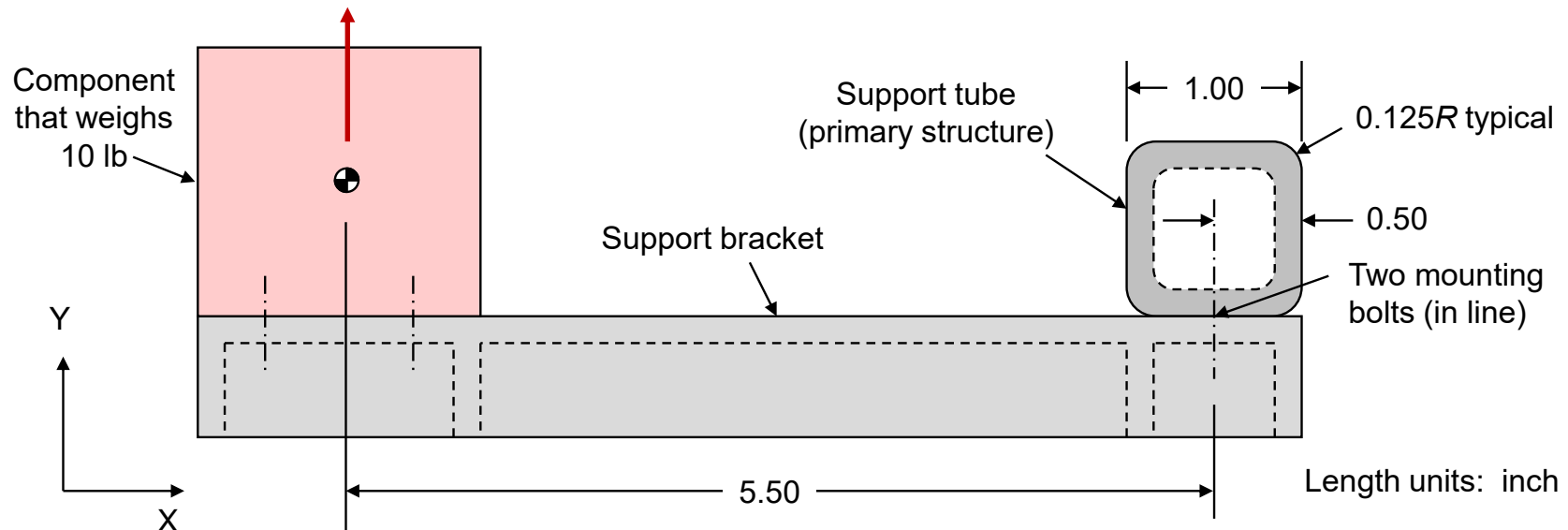

### Assumptions:

- (1) The two bolts share the load equally.
- (2) The bolts are in pure tension from prying (no bending moment in the bolts).
- (3) The support bracket has no mass.

## Often We Can Use Symmetry to Simplify the Analysis

This I-section is in pure tension, with a centroid that coincides with the centroid of the bolt pattern.

In other words, the line of action of the resultant applied load passes through the centroid of the bolt pattern.

**What's the peak bolt load?**

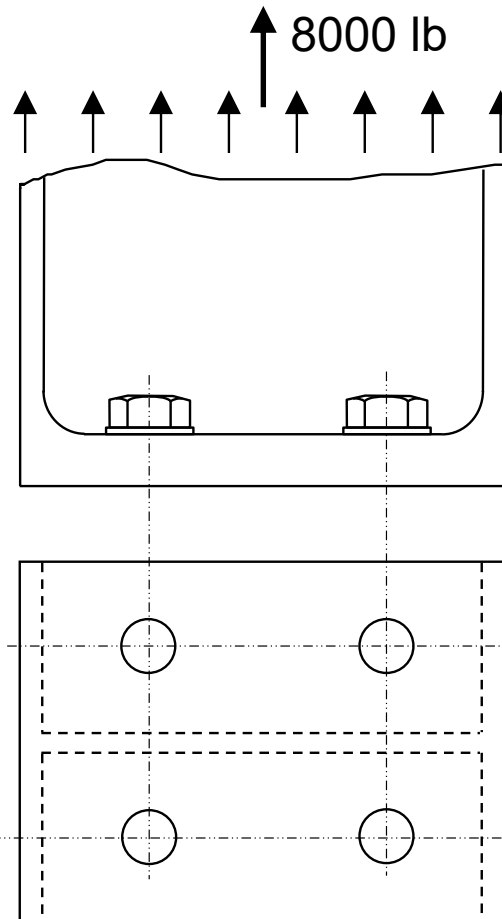

How do we know that two diagonally opposite bolts won't take more load than the other two?

**Answer: We don't. But, because of symmetry, the load path to each bolt has the same stiffness. Only as a result of dimensional tolerances should one bolt take more load than another.**

## Another Hypothetical Joint

With the C-channel cross section under pure tension, the line of action of the resultant applied load passes through the centroid of the bolt pattern (cross-section centroid coincides with bolt-pattern centroid).

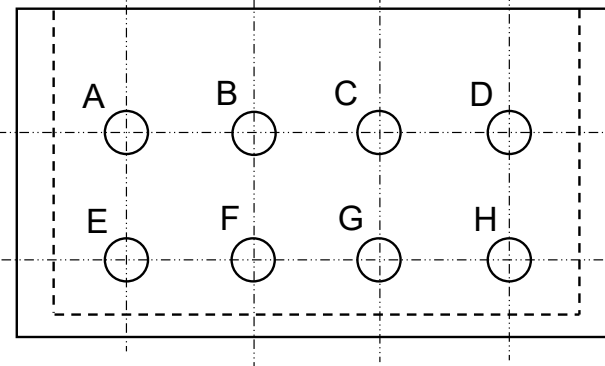
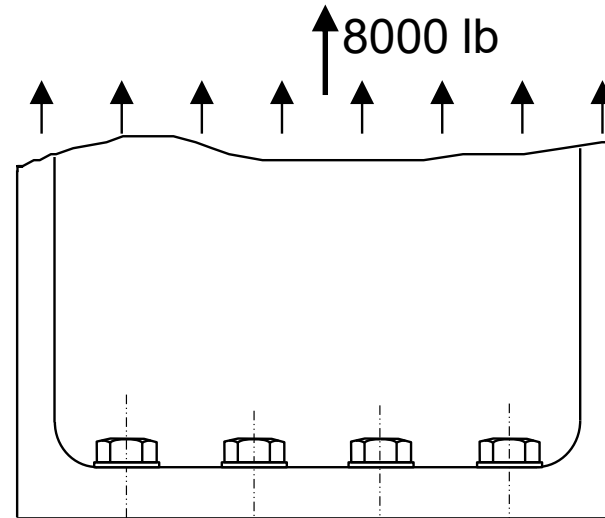

In a joint such as this (not *compact*), relative stiffness of redundant load paths dictates that some bolts will carry more load than others—even up to the point at which a ductile bolt will break.

### Options:

1. Use finite element analysis (FEA) to predict load distribution between bolts.
2. Make conservative assumptions.
3. Improve the design: Remove bolts B and C, and move bolts A and D up so that the centroid of the six-bolt pattern coincides with the line of action of the applied load.

**What's the peak bolt load?**

Bolts B and C don't carry much load.

## A Process for Calculating Bolt Loads in a Compact Joint

1. Identify the limit loads acting on the joint.
2. Make a quick estimate of bolt loads based on simplified assumptions.
3. Locate the centroid of the bolt pattern at the faying surface.
4. Transform the applied loads to the bolt-pattern centroid.
  - Load vectors ( $P_x, P_y, P_z, M_x, M_y, M_z$ )
5. Calculate bolt loads from the centroidal loads.
  - When justified, make assumptions based on symmetry and geometry
6. Compare results with your quick estimate for a sanity check.
7. Increase the computed bolt loads to account for the effects of potential misalignment and dimensional tolerances.
  - Or, if the part is already detailed, include the effects of tolerances in step 4.
8. Apply factors of safety to compute the design (applied) bolt loads.

## Example Problem 4-a: Estimating Bolt Loads for a Joint under Tension and Shear

Problem: For a limit load of 7200 lb (Step 1), calculate the limit bolt tensile load,  $P_{tL}$ , and shear load,  $P_{sL}$ , for the design shown below.

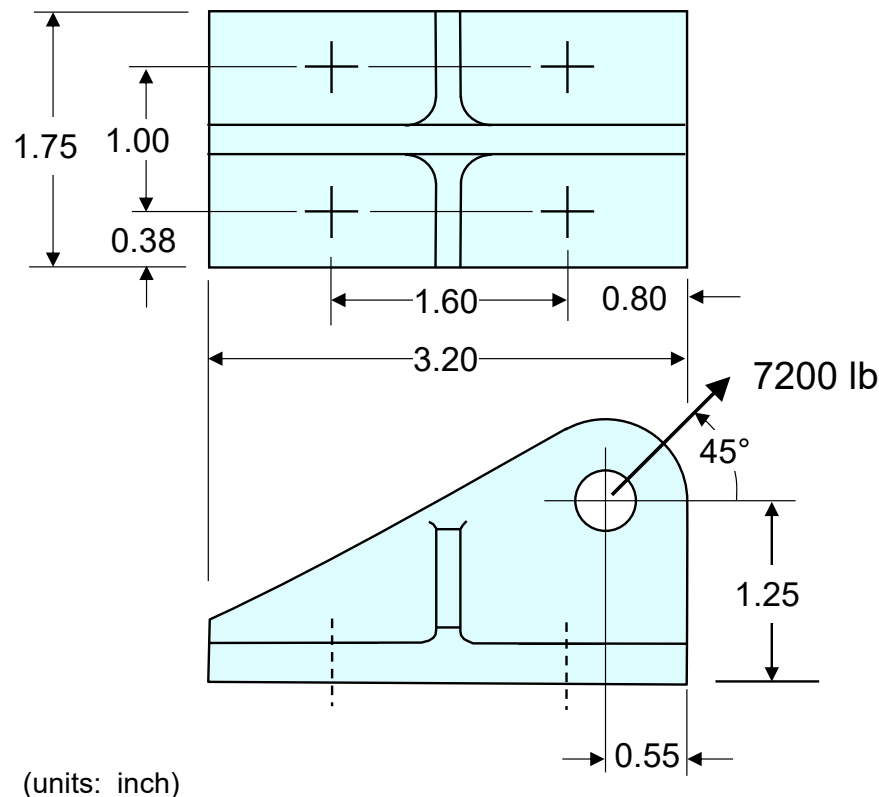

Step 2. Make a quick estimate.

The applied load appears to be aimed at the bolt centroid, and the cosine and sine of  $45^\circ$  are about 0.7. For tensile loading, stiffness is the same for each bolt, so each bolt should carry the same load. For shear loading, assuming the critical failure mode is ductile\* and the bolt holes are relatively tight\*\*, we can assume the bolts in this joint will share the applied loads equally.

$$P_{tL} \cong P_{sL} \cong \frac{5000}{4} = 1250 \text{ lb}$$

\*See discussion in Sec. 5 on bearing-critical and shear-critical shear joints. Check when sizing.

\*\*See suggested fitting factors for different hole sizes in Sec. 5.

continued

## Example Problem 4-a, continued: Using a Free-Body Diagram to Arrive at the Conclusions Shown on the Previous Page

Assuming the load line of action passes through the bolt-pattern centroid at the faying (mating) surface:

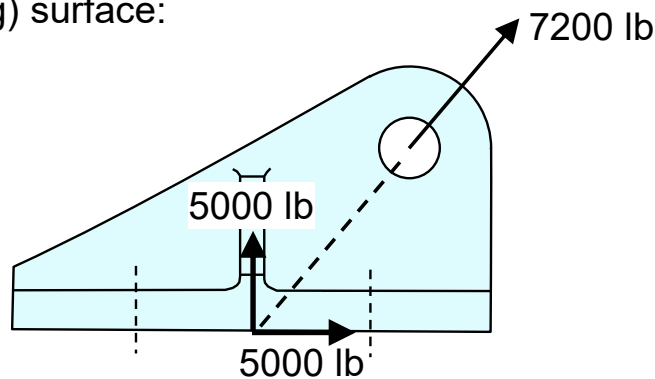

The applied load of 7200 lb can be projected down to the faying surface, which appears to be approximately at the centroid of the bolt pattern for this joint, and shown as two equal load vectors of approximately 5000 lb each.

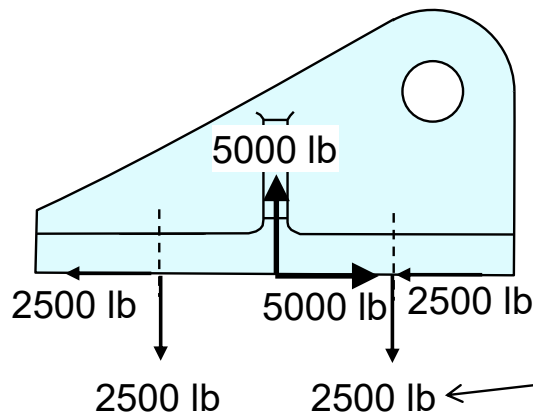

Total shear load in 2 bolts = 2500 lb, or 1250 lb per bolt, based on the assumption that the bolts equally share the load. (See Sec. 5 for suggested fitting factors when making this assumption.)

Total tensile load in 2 bolts = 2500 lb, or 1250 lb per bolt

continued

## Example Problem 4-a, continued

3. Locate the bolt-pattern centroid at the faying surface:

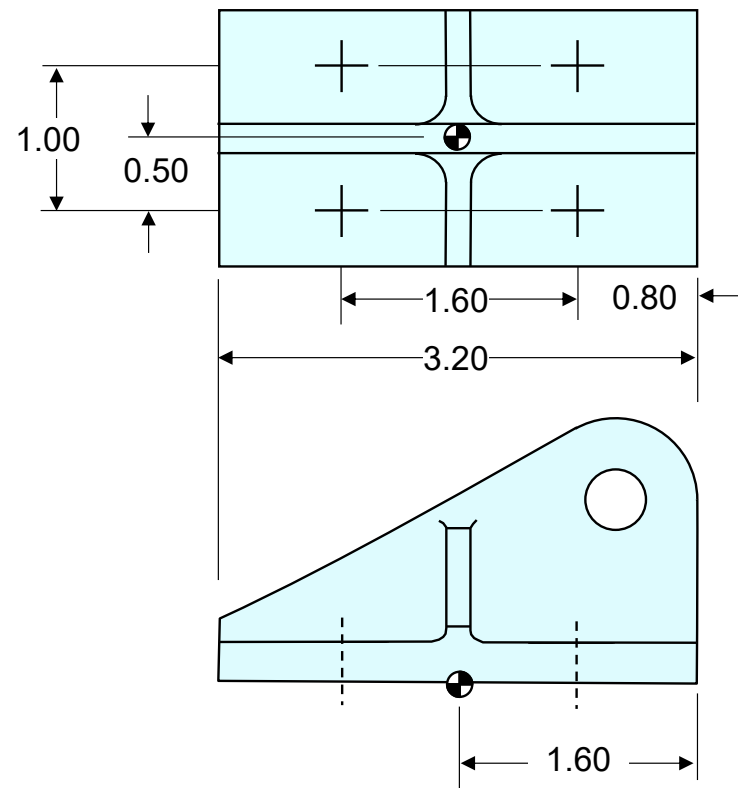

continued

## Example Problem 4-a, continued

4. Transform the applied load to the bolt-pattern centroid:

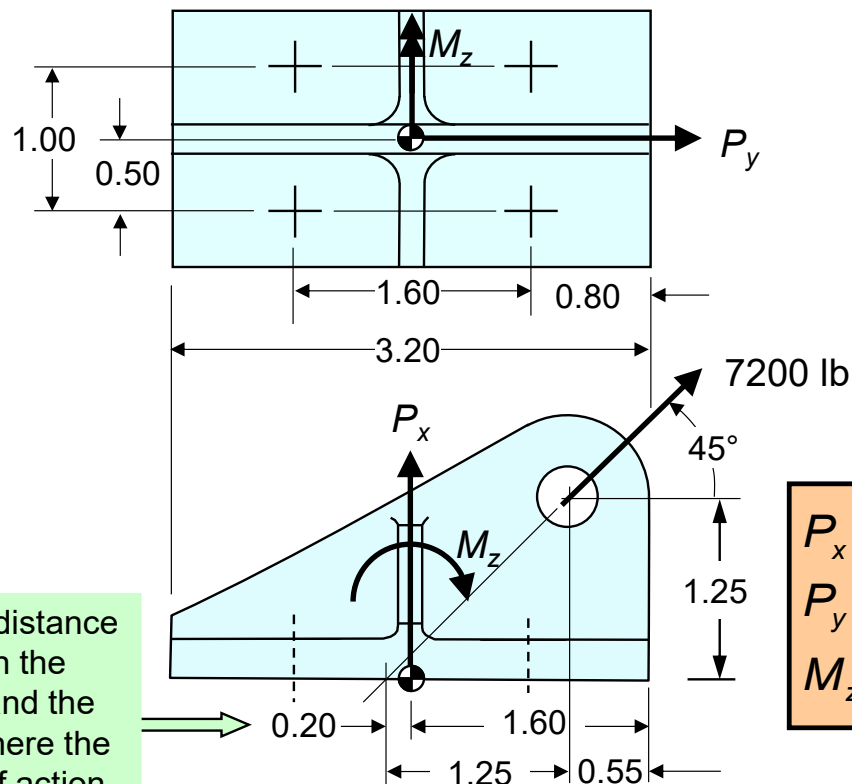

The load line of action misses the centroid by 0.2" in the y direction.

We didn't account for this misalignment in our initial estimate (step 2).

This is the distance between the centroid and the location where the load line of action crosses the mating surface.

$$P_x = 7200 \sin 45^\circ = 5090 \text{ lb}$$

$$P_y = 7200 \cos 45^\circ = 5090 \text{ lb}$$

$$M_z = 0.20 P_x = 1020 \text{ in-lb}$$

continued

## Example Problem 4-a, continued

5. Calculate bolt loads from the centroidal loads:

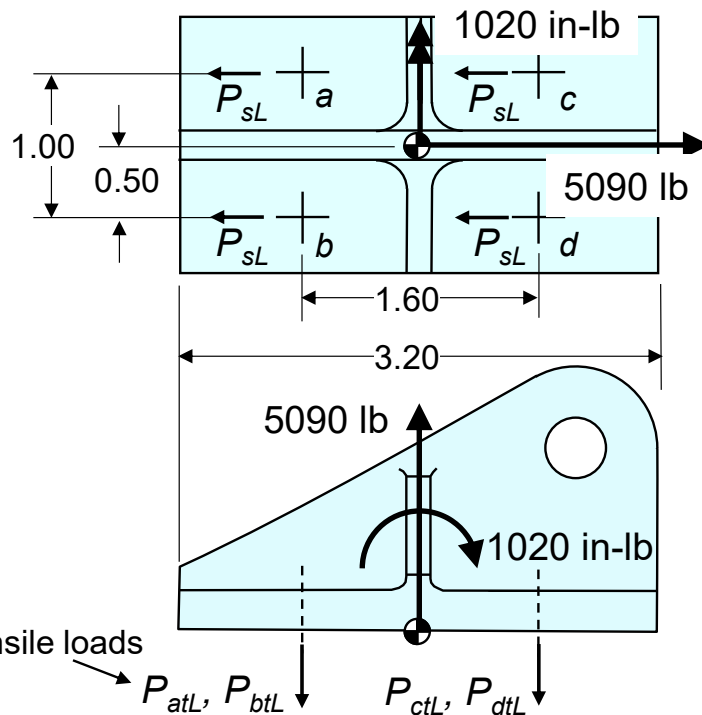

Bolt tensile loads

If there is a possibility of rupture before much plastic deformation occurs (e.g., a shear-critical joint), assume only two bolts carry the shear.

Limit bolt tensile load:

$$P_{tL} = \frac{5090}{4} + \frac{1020}{2(1.60)} = 1590 \text{ lb}$$

2 bolts in tension,  
2 in compression

Reasonably close  
to our estimates  
(step 6)

Limit bolt shear load:

$$P_{sL} = \frac{5090}{4} = 1270 \text{ lb}$$

Key assumptions in the above:

- The centroidal forces are carried equally by the bolts.
- The centroidal moments are reacted solely by the bolts (no prying).
- The part and hole pattern are made to nominal (shown) dimensions.

continued

## Example Problem 4-a, continued: Be Sure to Account for Dimensional Tolerances and Misalignments!

Example: Because of dimensional tolerances, the load  $P$  can be misaligned in both translation and rotation, causing prying on the fasteners and potential premature failure.

To a lesser amount, dimensional tolerances affect the bolt loads in our on-going example (4-a).

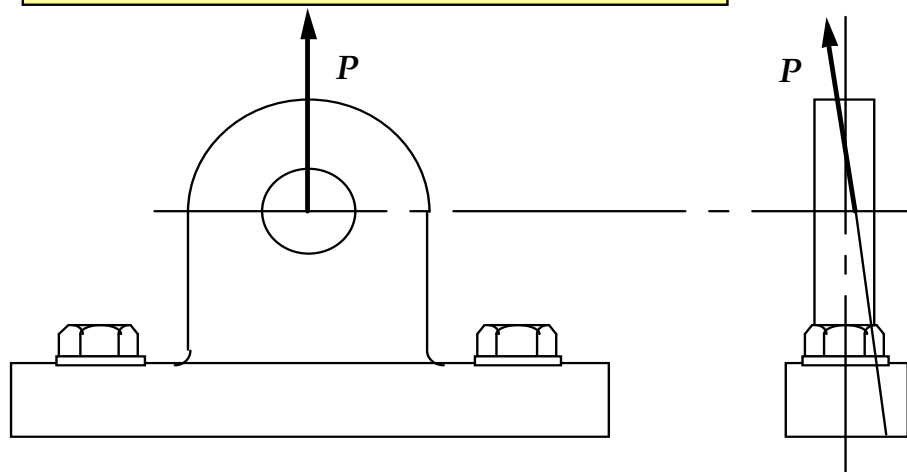

**Recommendation:**  
Before final dimensioning of the parts, when tolerances aren't yet specified, design the part for an assumed misalignment (perhaps 0.050") or an assumed effect of misalignment. (See next page.)

continued

## Example Problem 4-a, conclusion

7. Increase the calculated bolt loads to account for the effects of potential misalignment and dimensional tolerances:

As a first-cut analysis in preliminary design, before specifying dimensional tolerances, we want to find a simple way to make the design robust and be able to tolerate imperfection. For this design, let's increase the computed bolt loads by 10%:

$$P_{tL} = 1.1(1590) = 1750 \text{ lb}$$

$$P_{sL} = 1.1(1270) = 1400 \text{ lb}$$

This value is based on engineering judgment for this problem. See the appendix to this section for an example of how we might account for tolerances in more detail for this joint.

8. Apply factors of safety (can be done in an earlier step). If the ultimate factor of safety is 1.4 and the fitting factor is 1.15, the design ultimate bolt loads are

$$P_{tu} = 1.4(1.15)(1750) = 2820 \text{ lb}$$

$$P_{su} = 1.4(1.15)(1400) = 2250 \text{ lb}$$

## Improving Our Process to Generate Equations for Automation

Follow the same basic process (p. 4-15), but derive equations for bolt loads in terms of applied loads as variables.

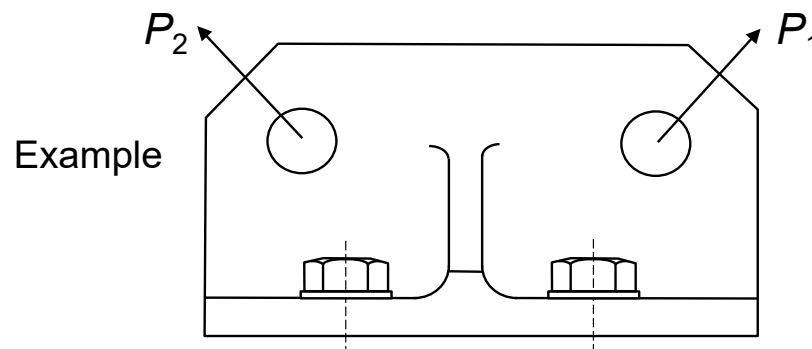

- Develop equations for transforming the applied loads to the bolt-pattern centroid, keeping  $P_1$  and  $P_2$  as variables.
- Develop equations for bolt loads in terms of the centroidal loads, as before, but still keeping  $P_1$  and  $P_2$  as variables.
- Combine equations so that you have bolt loads in terms of  $P_1$  and  $P_2$ .

**This approach makes it easy to assess changing design loads. Predicted launch loads can change often on a space program.**

## Improved Process

1. Identify the applied loads acting on the joint **and designate them as variables.**
2. Make a quick estimate of bolt loads based on simplified assumptions.
3. Locate the centroid of the bolt pattern at the faying surface.
4. Write equations for transforming the applied loads in Step 1, as variables, to the bolt-pattern centroid, then solve for the centroidal loads given the actual applied loads.
5. Develop equations for bolt loads in terms of the centroidal loads, then solve for the bolt loads given the actual applied loads.
  - Include effects of potential misalignment and tolerances here or later in the process.
6. Compare results with your quick estimate from Step 2.
7. **Combine equations from Steps 4 & 5 to form equations for bolt loads in terms of the load variables from Step 1. (new step)**
8. Calculate bolt loads using these equations and check with the results of Step 5.
9. Apply factors of safety to compute the design bolt loads.

See appendix to this section for Example Problem 4-a reworked with this process (4-b).

## Class Problem 4-2: Compute Limit Tensile and Shear Bolt Loads for Detail A, Station 0

Use the process described on the previous page so that you have simplified equations in case the design loads change later on.

To simplify the problem, we will consider only two dimensions.

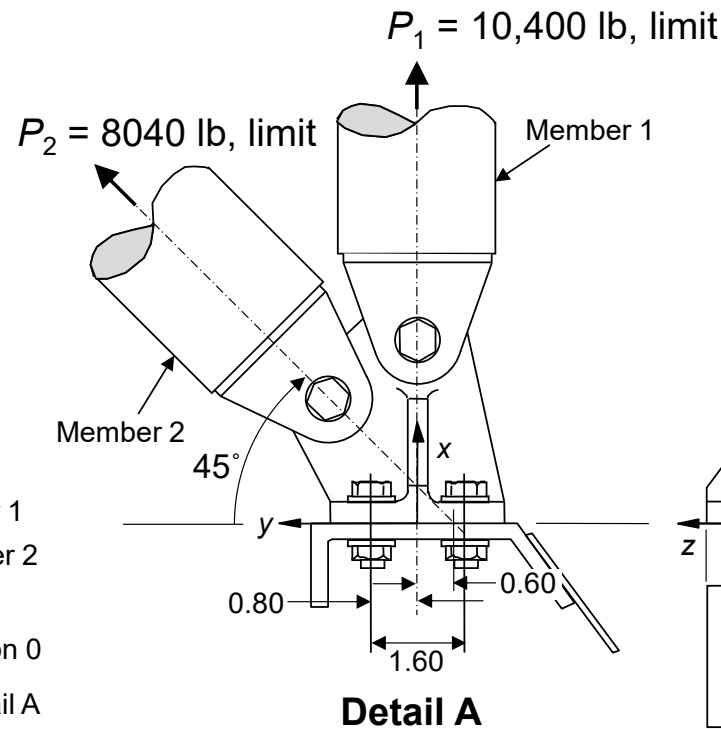
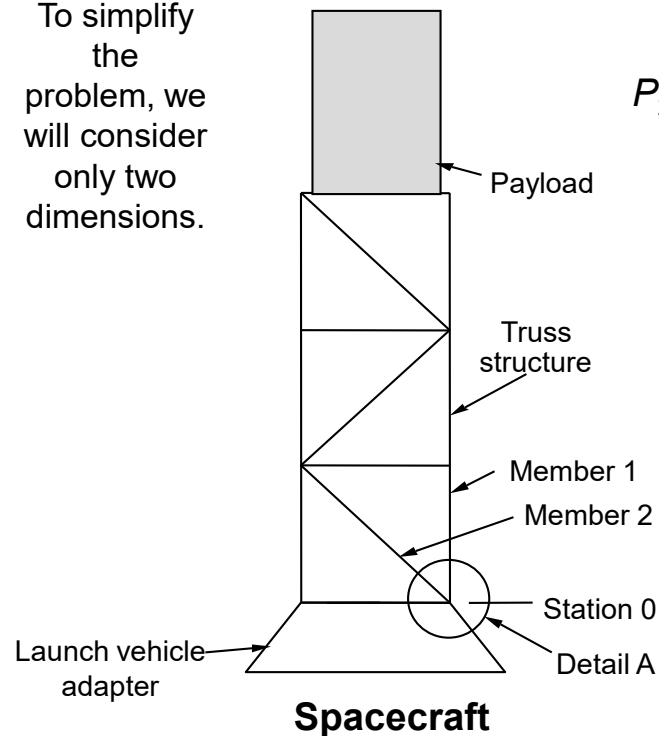

Assume the joint is bearing critical (ductile failure) rather than shear critical, with relatively tight holes.

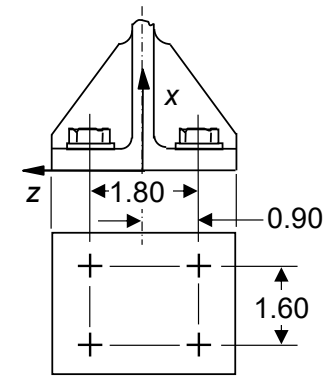

Dimensions are in inch units

Projected views

Increase predicted loads by 10% to account for potential misalignment from tolerances.

# Appendix to Section 4

## More Examples of Calculating Bolt Loads

## Example Problem 4-b: Reworking Example Problem 4-a with Improved Process

Problem: Rework Example Problem 4-a, this time calculating bolt tensile and shear loads in terms of applied force  $P$ .

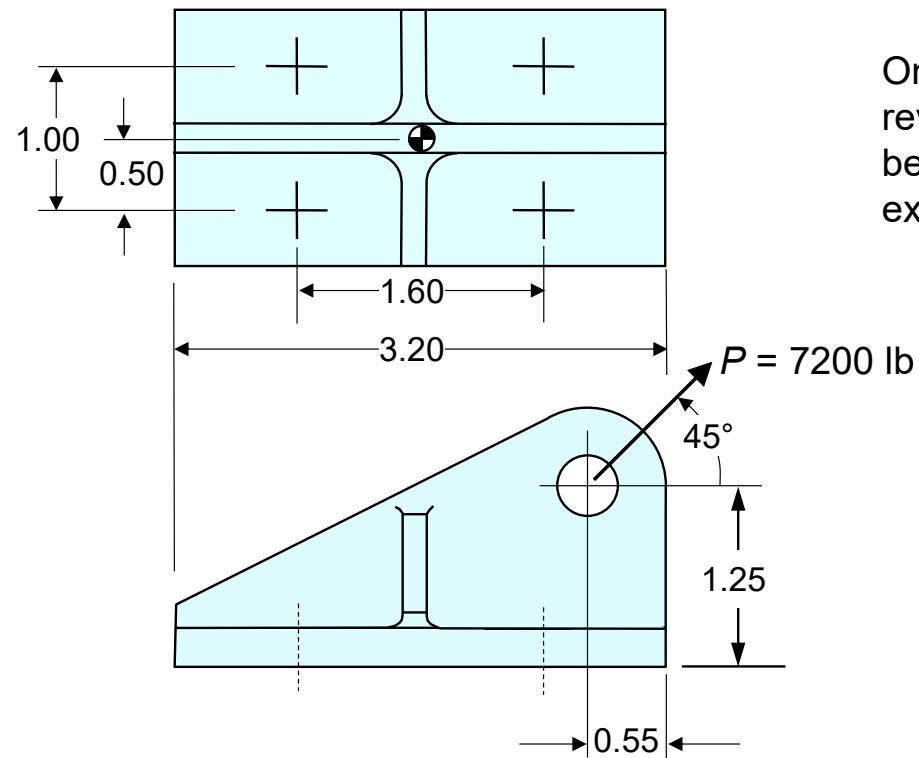

Only the new or revised steps will be shown for this example.

continued

## Example Problem 4-b, continued

4. Transform the applied load to the bolt-pattern centroid:

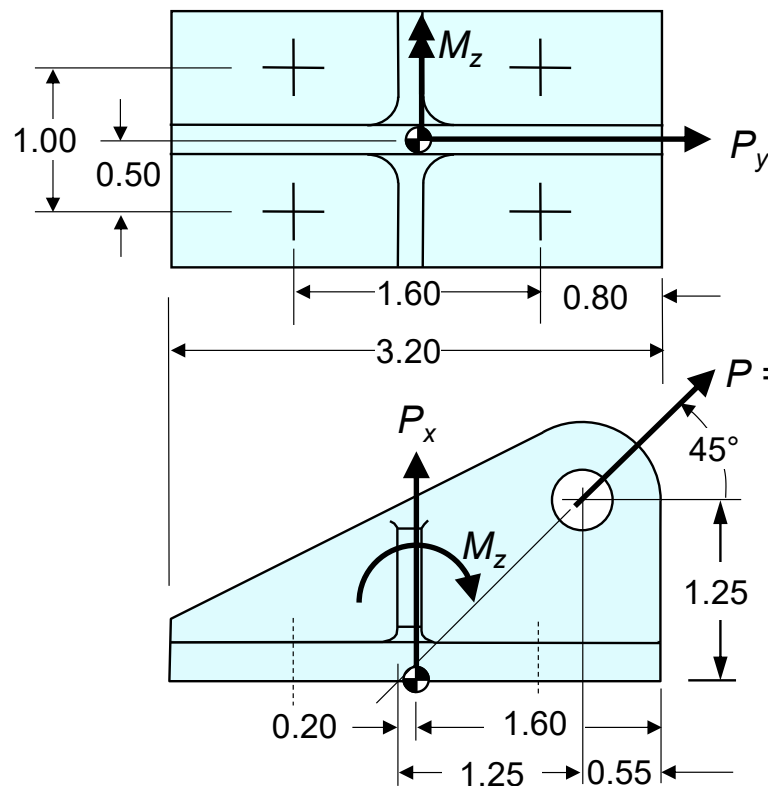

$$P_x = P \sin 45^\circ = 0.707P$$

$$P_y = P \cos 45^\circ = 0.707P$$

$$M_z = 0.20P_x = 0.141P$$

Calculate bolt loads for the actual applied load of 7200 lb:

$$P_x = 0.707(7200) = 5090 \text{ lb}$$

$$P_y = 0.707(7200) = 5090 \text{ lb}$$

$$M_z = 0.141(7200) = 1020 \text{ in-lb}$$

continued

## Example Problem 4-b, continued

5. Compute bolt limit tensile and shear loads ( $P_{tL}$  and  $P_{sL}$ ) in terms of the centroid loads:

1.1 factor to account for tolerances

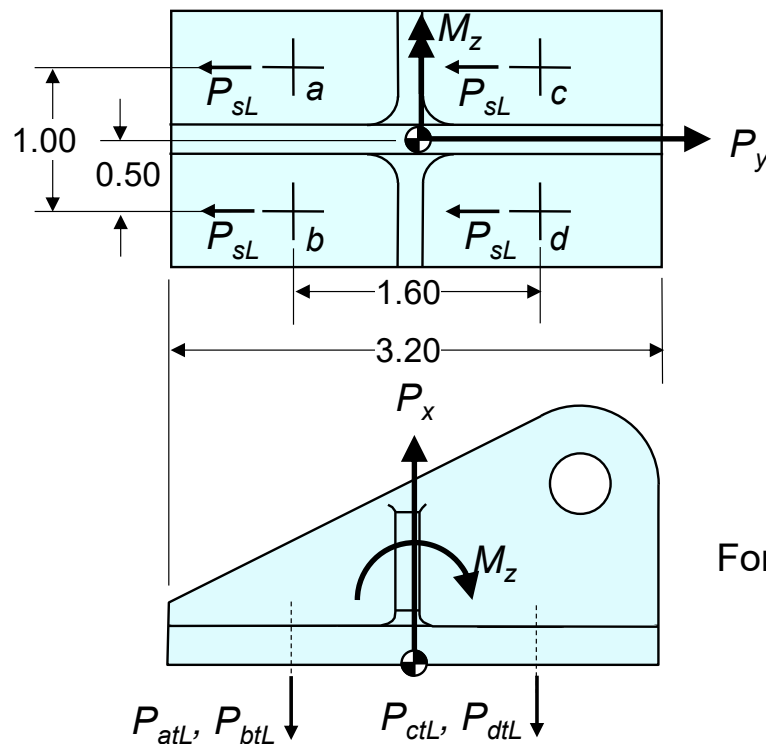

$$P_{tL} = 1.1 \left[ \frac{P_x}{4} \pm \frac{M_z}{2(1.60)} \right]$$

$$= 0.275P_x \pm 0.344M_z$$

$$P_{sL} = 1.1 \left[ \frac{P_y}{4} \right] = 0.275P_y$$

See Example 4-a for assumptions

For the actual applied load of 7200 lb:

$$P_{tL} = 0.275(5090) + 0.344(1020) = 1750 \text{ lb}$$

$$P_{sL} = 0.275(5090) = 1400 \text{ lb}$$

Check: The same numbers we got in Example 4-a

continued

## Example Problem 4-b, conclusion

7. Now combine equations to compute limit bolt loads in terms of applied load  $P$ :

$$P_{tL} = 0.275(0.707P) + 0.344(0.141P) = 0.243P$$

$$P_{sL} = 0.275(0.707P) = 0.194P$$

8. For a limit load  $P = 7200$  lb, calculate the limit tensile and shear loads in the bolts using the equations developed above.

$$P_{tL} = 0.243(7200) = 1750 \text{ lb}$$

$$P_{sL} = 0.194(7200) = 1400 \text{ lb}$$

These are the same loads we got on the previous page.

**We now have two simple, validated equations for bolt loads in terms of the limit load,  $P$ . If  $P$  changes, we can quickly recalculate bolt loads.**

**This approach can be used for problems far more complex than this one.**

**Remember to include any applicable fitting factor and factor of safety.**

## Example Problem 4-c: Accounting for Misalignment in Example Problem 4-b

Let's assume the final dimensional tolerances give a possible misalignment of 0.050", as shown below:

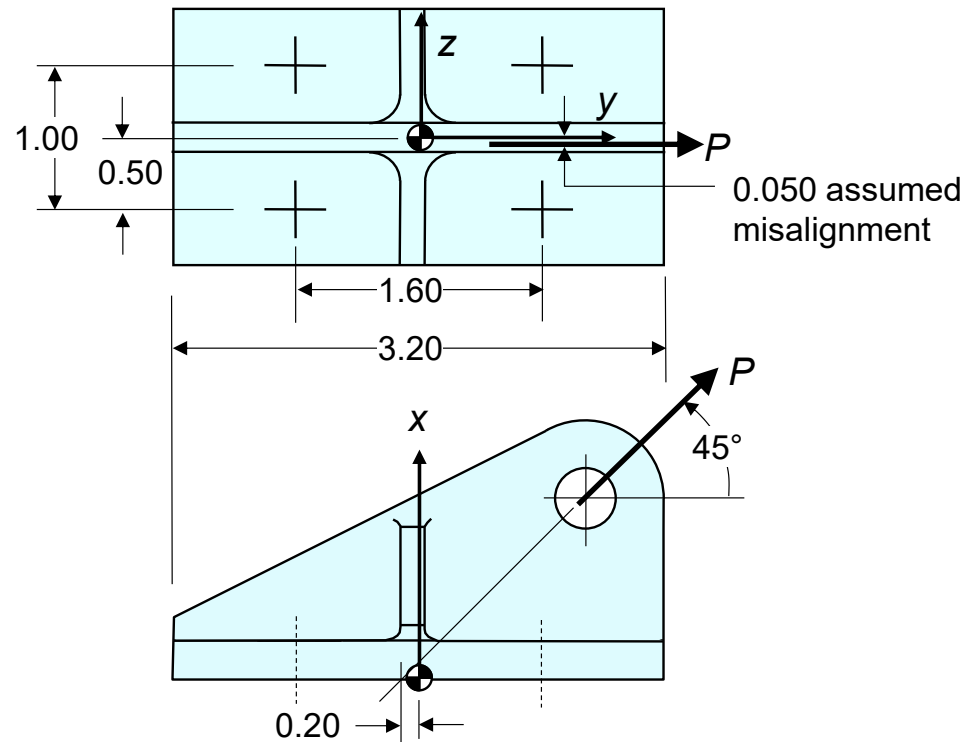

continued

## Example Problem 4-c, continued

How does this 0.050" misalignment affect the bolt loads?

It causes two additional moments about the bolt centroid:  $M_x$  and  $M_y$

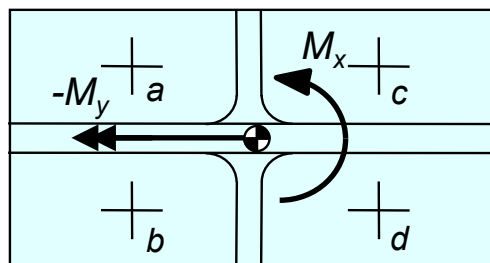

$$M_x = 0.050P_y = 0.050(0.707P) = 0.0354P$$

$$M_y = -0.050P_x = -0.050(0.707P) = -0.0354P$$

$-M_y$  causes additional tension in bolts  $b$  and  $d$ :

$$\Delta P_{btL} = \Delta P_{dtL} = \frac{-M_y}{2(1.00)} = \frac{0.0354P}{2(1.00)} = 0.0177P$$

Making the total tension in bolt  $b$  equal to

$$P_{tL} = P_{btL} = 0.221P + 0.0177P = 0.239P$$

as compared with  $P_{tL} = 0.243P$  calculated earlier with a 1.1 factor to account for misalignment.

continued

## Example Problem 4-c, continued

Centroidal torque,  $M_x$ , is reacted by y and z components of shear in the bolts.

Assume the magnitude of shear force is proportional to distance from centroid:

$$P_{ay2} = \left( \frac{0.50}{0.80} \right) P_{az2}$$

$$P_{ay2} = -P_{by2} = P_{cy2} = -P_{dy2}$$

$$P_{az2} = P_{bz2} = -P_{cz2} = -P_{dz2}$$

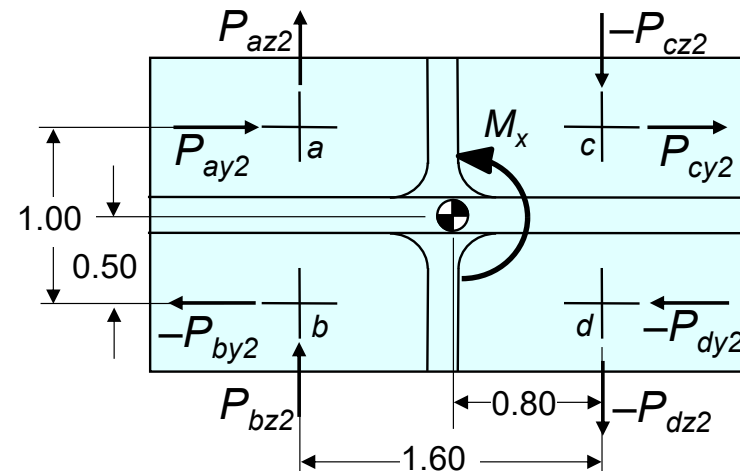

The total torque about the centroid from bolt shear forces must balance the applied torque,  $M_x$ :

$$M_x = 4(0.80)P_{az2} + 4(0.50)P_{ay2}$$

$$= 4(0.80)P_{az2} + 4(0.50) \left[ \frac{0.50}{0.80} \right] P_{az2}$$

$$= 4.45P_{az2}$$

$$P_{az2} = \frac{M_x}{4.45} = \frac{0.0354P}{4.45} = 0.0080P$$

Substitute from above

Substitute from equation on previous page

continued

## Example Problem 4-c, conclusion

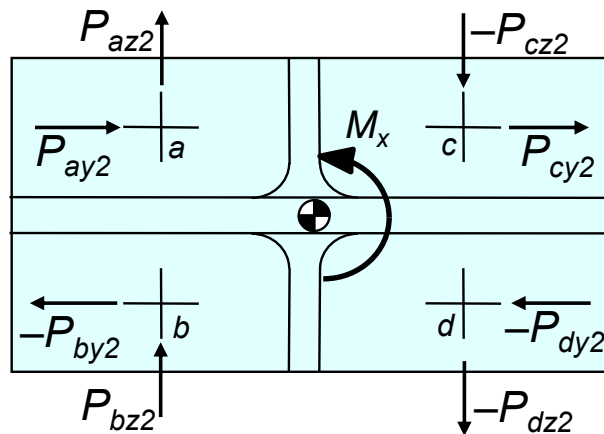

From previous page:

$$P_{bz2} = P_{az2} = 0.0080P$$

$$P_{ay2} = \left(\frac{0.50}{0.80}\right)P_{az2} = \left(\frac{0.50}{0.80}\right)(0.0080P) = 0.0050P$$

$$P_{by2} = -P_{ay2} = -0.0050P$$

This force is additive to the shear force computed earlier, making the total y component of shear force equal to

$$P_{by} = -0.0050P - 0.177P = -0.182P$$

The total limit shear force in bolt *b* is the vector sum of the two force components:

$$P_{sL} = \sqrt{P_{bz2}^2 + P_{by}^2} = \sqrt{(0.0080P)^2 + (-0.182P)^2} = 0.182P$$

**This was a lot of work. It pays to make simplifying assumptions when we can do so confidently!**

as compared with  $P_{sL} = 0.194P$  calculated with the assumption of 10% extra bolt load caused by misalignment

## Example Problem 4-d: Estimating Bolt Loads for a More Complex Tension Joint

1. Problem statement: Calculate the peak bolt tension for the applied loads shown.

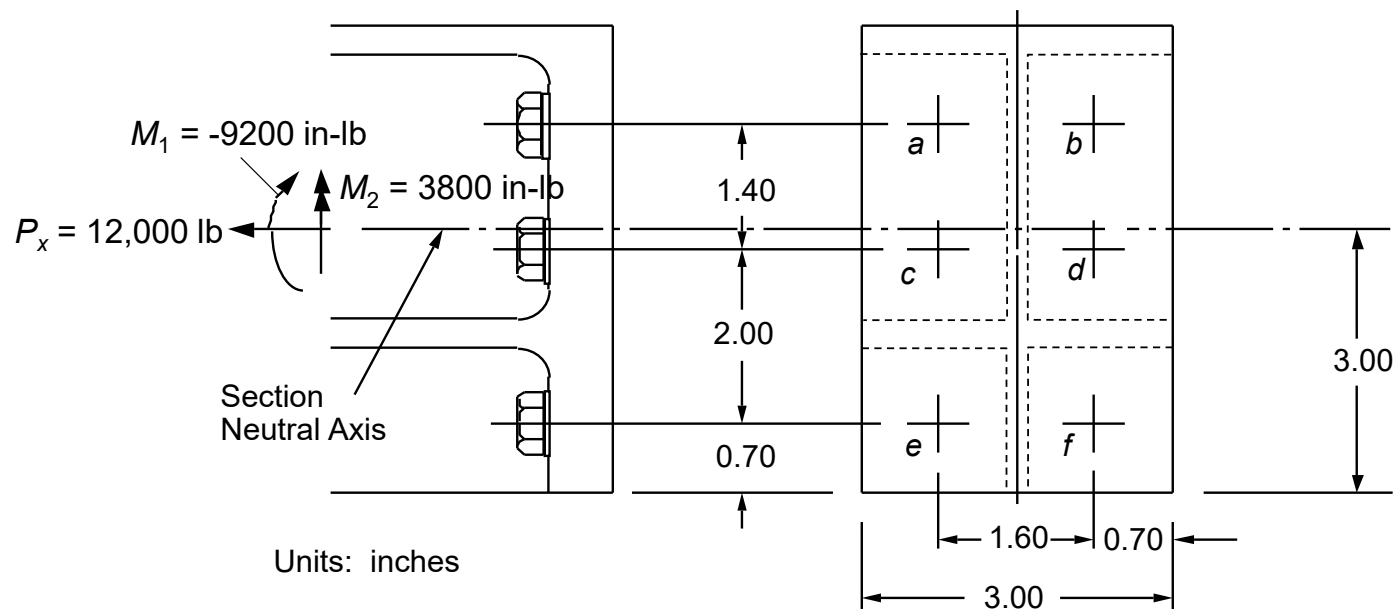

2. Make a quick estimate.

**What is your estimate, and what is your reasoning?**

continued

## Example Problem 4-d, continued

3. Locate the centroid of the bolt pattern:

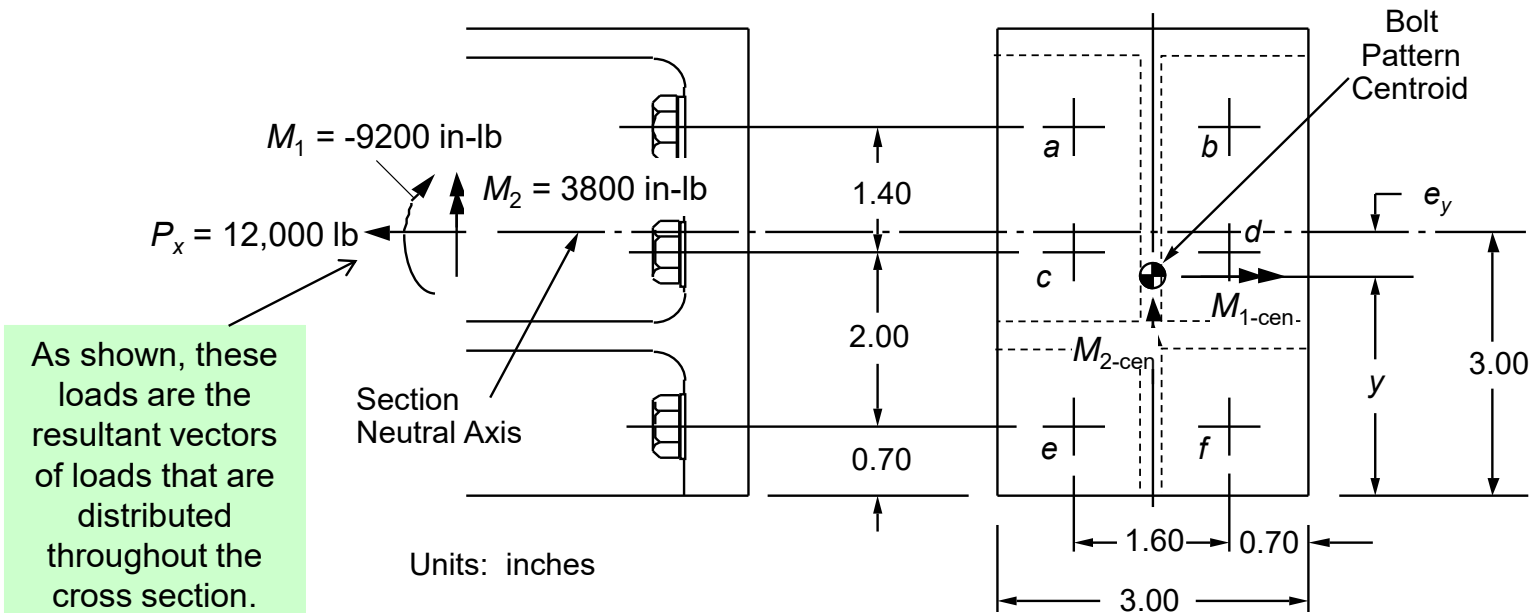

$$y = \frac{2}{6} [0.70 + (2.00 + 0.70) + (1.40 + 2.00 + 0.70)] = 2.50''$$

$$e_y = 3.00 - 2.50 = 0.50''$$

continued

## Example Problem 4-d, continued

4. Transform member loads to bolt-pattern centroid.

$$\begin{aligned}M_{1\text{-cen}} &= M_1 - e_y P_x = M_1 - 0.50P_x \\M_{2\text{-cen}} &= M_2 \pm 0.050P_x\end{aligned}$$

assumed 0.050" maximum misalignment

Solve for centroidal loads for the given applied loads:

$$\begin{aligned}M_{1\text{-cen}} &= -9200 - 0.50(12,000) = -15,200 \text{ in - lb} \\M_{2\text{-cen}} &= 3800 + 0.050(12,000) = 4400 \text{ in - lb}\end{aligned}$$

continued

## Example Problem 4-d, continued

5. Compute bolt loads in terms of centroidal loads:

Let's separately work out the contributions ( $P_{t0}$ ,  $P_{t1}$ , and  $P_{t2}$ ) of the three applied loads.

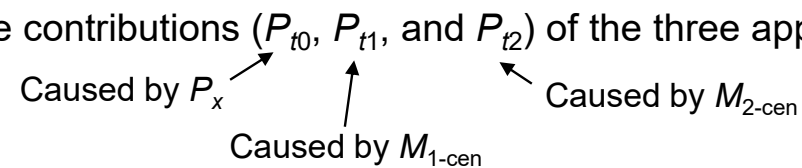

a. caused by axial load,  $P_x$ :

$$P_{t0} = \frac{P_x}{6} = 0.167P_x$$

b. caused by weak-axis moment,  $M_{2-cen}$ :

$$P_{t2} = \frac{\pm M_{2-cen}}{3(1.60)} = \pm 0.208M_{2-cen}$$

continued

## Example Problem 4-d, continued

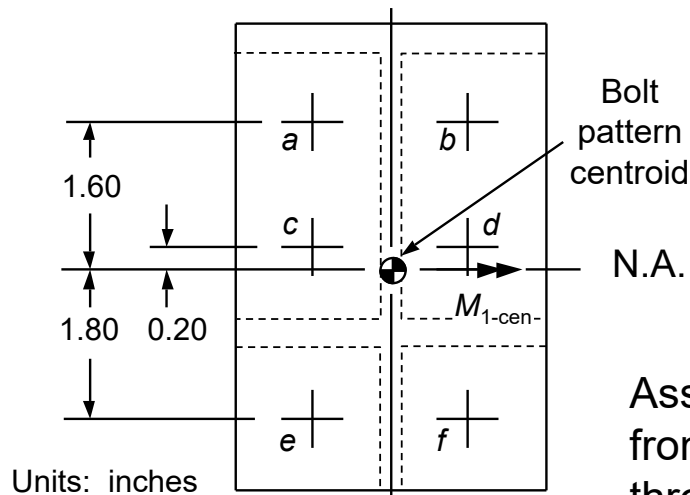

c. bolt tension caused by  $M_{1-cen}$

Note regarding sign convention: A positive  $M_{1-cen}$  causes tension in bolts  $e$  &  $f$  and compression in bolts  $a - d$  (based on our assumption that loads are carried only by bolts).

Assuming bolt loads are proportional to distance from the neutral axis (N.A.), which passes through the centroid:

Bolt tension caused by  $M_{1-cen} \Rightarrow$

$$P_{at1} = P_{bt1} ; P_{ct1} = P_{dt1} ; P_{et1} = P_{ft1}$$

$$P_{at1} = -\left(\frac{1.60}{1.80}\right)P_{et1} ; P_{ct1} = -\left(\frac{0.20}{1.80}\right)P_{et1}$$

continued

## Example Problem 4-d, continued

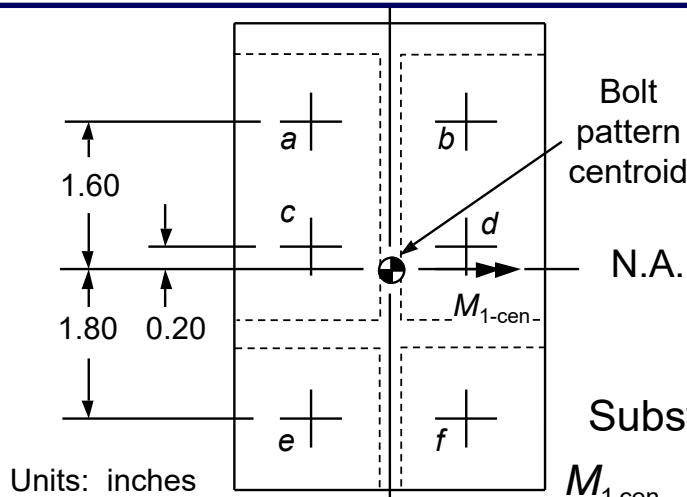

c. bolt tension caused by  $M_{1-cen}$  (continued)

The forces in the bolts must balance the applied moment at the centroid.

Substitute:

$$\begin{aligned}
 M_{1-cen} &= 2(1.80)P_{et1} - 2(0.20)P_{ct1} - 2(1.60)P_{at1} \\
 &= 2(1.80)P_{et1} - 2(0.20)\left(\frac{-0.20}{1.80}\right)P_{et1} - 2(1.60)\left(\frac{-1.60}{1.80}\right)P_{et1} \\
 &= 3.600P_{et1} + 0.044P_{et1} + 2.844P_{et1} = 6.49P_{et1}
 \end{aligned}$$

Bolt loads:

$$\text{e and f: } P_{et1} = P_{ft1} = \frac{1}{6.49} M_{1-cen} = 0.154 M_{1-cen}$$

$$\text{a and b: } P_{at1} = P_{bt1} = -\left(\frac{1.60}{1.80}\right) P_{et1} = -0.137 M_{1-cen}$$

No need to calculate loads in bolts c and d

**Why?**

continued

## Example Problem 4-d, continued

Combining terms, we find the limit tensile load in bolts *e* & *f*:

$$\begin{aligned}
 P_{ftL}, P_{etL} &= P_{t0} + P_{et1} \pm P_{t2} \\
 &= 0.167P_x + 0.154M_{1\text{-cen}} \pm 0.208M_{2\text{-cen}} \quad \text{(two equations)}
 \end{aligned}$$

from axial force      from strong-axis moment      from weak-axis moment

And the limit tensile load in bolts *a* & *b*:

$$\begin{aligned}
 P_{btL}, P_{atL} &= P_{t0} + P_{at1} \pm P_{t2} \\
 &= 0.167P_x - 0.137M_{1\text{-cen}} \pm 0.208M_{2\text{-cen}} \quad \text{(two equations)}
 \end{aligned}$$

Given  $P_x = 12,000$  lb,  $M_{1\text{-cen}} = -15,200$  in-lb, and  $M_{2\text{-cen}} = 4400$  in-lb, the limit tensile load is highest in bolt *b*:

$$\begin{aligned}
 P_{tL} = P_{btL} &= 0.167(12,000) - 0.137(-15,200) + 0.208(4400) \\
 &= 2000 + 2080 + 917 = \mathbf{5000 \text{ lb}}
 \end{aligned}$$

6. Compare with our quick estimate: Does the answer make sense? continued

## Example Problem 4-d, continued

7. Combine equations from Steps 4 and 5:

$$\text{From Step 4: } M_{1\text{-cen}} = M_1 - e_y P_x = M_1 - 0.50P_x$$

$$M_{2\text{-cen}} = M_2 \pm 0.050P_x$$

$$\text{From Step 5: } P_{ftL}, P_{etL} = 0.167P_x + 0.154M_{1\text{-cen}} \pm 0.208M_{2\text{-cen}}$$

$$P_{btL}, P_{atL} = 0.167P_x - 0.137M_{1\text{-cen}} \pm 0.208M_{2\text{-cen}}$$

Combined:

$$\begin{aligned} P_{ftL}, P_{etL} &= 0.167P_x + 0.154(M_1 - 0.50P_x) \pm 0.208(M_2 \pm 0.050P_x) \\ &= 0.100P_x + 0.154M_1 \pm 0.208M_2 \end{aligned}$$

$$\begin{aligned} P_{btL}, P_{atL} &= 0.167P_x - 0.137(M_1 - 0.50P_x) \pm 0.208(M_2 \pm 0.050P_x) \\ &= 0.246P_x - 0.137M_1 \pm 0.208M_2 \end{aligned}$$

continued

## Example Problem 4-d, conclusion

8. Calculate bolt loads:

Given  $P_x = 12,000$  lb,  $M_1 = -9200$  in-lb, and  $M_2 = 3800$  in-lb, use the equations we just derived (repeated below) to find the highest bolt load.

$$\begin{aligned} P_{ftL}, P_{etL} &= 0.100P_x + 0.154M_1 \pm 0.208M_2 \\ &= 570 \text{ lb}, -1010 \text{ lb} \end{aligned}$$

$$\begin{aligned} P_{btL}, P_{atL} &= 0.246P_x - 0.137M_1 \pm 0.208M_2 \\ &= 5000 \text{ lb}, 3420 \text{ lb} \end{aligned}$$

↖ Limit tensile load,  $P_{tL}$

Same as we had before (Step 5). We have derived and validated four equations that will find the highest bolt load regardless of the combination of applied loads.

We can put these equations into a spreadsheet or possibly directly into the loads analysis.

## Example Problem 4-e: Same Joint as for Example Problem 4-d, but Loaded Only by Moment $M_2$

**When there is little or no applied axial force, a joint can react a bending moment by heel-and-toe action (prying).**

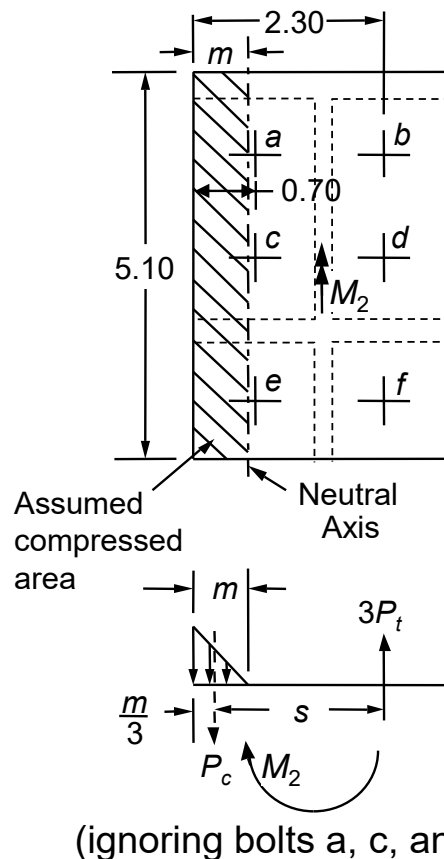

1. Find location of neutral axis,  $m$ :  
 3 bolts at 2.30" from edge  
 3 bolts at 0.70" from edge

$$m = \frac{5.10m\left(\frac{m}{2}\right) + 3(2.30 + 0.70)\left(\frac{E_b}{E_c}\right)A_s}{5.10m + 6\left(\frac{E_b}{E_c}\right)A_s}$$

$E_b$  = bolt modulus of elasticity  
 $E_c$  = fitting modulus of elasticity  
 $A_s$  = cross-sectional area of a bolt's full-diameter body

This equation reduces to

$$2.55m^2 + \left(\frac{6E_bA_s}{E_c}\right)m - \frac{9.00E_bA_s}{E_c} = 0$$

Let's assume the fittings are aluminum ( $E_c = 10.5 \times 10^6$  psi) and the bolts are steel ( $E_b = 29 \times 10^6$  psi), 5/16" dia. ( $A_s = 0.0767$  in<sup>2</sup>).

Substituting values and using the quadratic equation,  **$m = 0.651$ "**

(ignoring bolts a, c, and e) (This method is approximate, adapted from the method used for analyzing a reinforced concrete beam. See Ref. 49, p. 14-10, as well as other civil engineering references.)

continued

## Example Problem 4-e, conclusion

To simplify the problem, let's ignore the contributions of bolts *a*, *c*, and *e*:

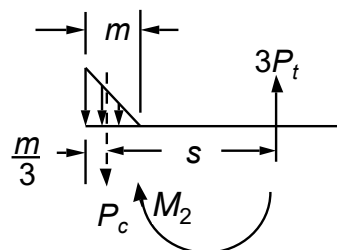
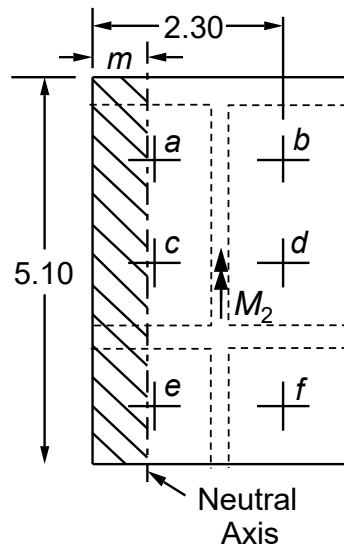

(ignoring bolts *a*, *c*, and *e*)

2. Compute the couple distance *s* for reacting the applied moment:

$$s = 2.30 - \frac{m}{3} = 2.30 - \frac{0.651}{3} = 2.08''$$

3. Calculate tension in bolts *b*, *d*, and *f*

$$M_2 = 3P_t s$$

$$P_t = \frac{M_2}{3s} = \frac{M_2}{3(2.08)} = 0.160M_2$$

vs.  $P_t = 0.208M_2$  when we assumed earlier that the moment is carried solely by the bolt pattern. The heel-and-toe assumption reduces the bolt load by 23%.

**But we can't assume the heel-and-toe load path exists while also assuming an applied axial load is divided solely between the bolts.**

**Why not?**

**Because we'd be using two conflicting assumptions.**

**Example Problem 4-f: Same Joint as for Example Problems 4-d and 4-e:  
Trying the Method Used in Problem 4-e with both  $P_x$  and  $M_2$  Applied**

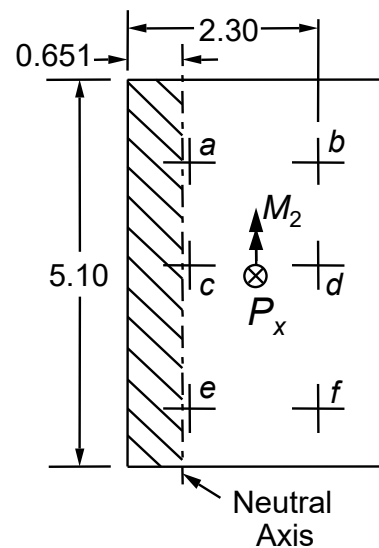

- To simplify this problem, let's assume the axial force,  $P_x$ , is aligned with the bolt-pattern centroid.
- We are tempted to divide  $P_x$  by 6 bolts and assume the moment is reacted by heel-and-toe action:

$$P_t = 0.167P_x + 0.160M_2$$

- But dividing  $P_x$  by 6 is based on the assumption that the neutral axis passes through the bolt centroid. The compressed area of aluminum is ignored.
- The assumed locations for the neutral axis are inconsistent: If the joint carries moment as shown at left, the axial load,  $P_x$  increases the moment by  $P_x$  times distance to neutral axis.
- Thus, the above equation is unconservative.
- Let's calculate bolt tension based on the assumption of heel and toe. (Next page)

continued

## Example Problem 4-f, continued

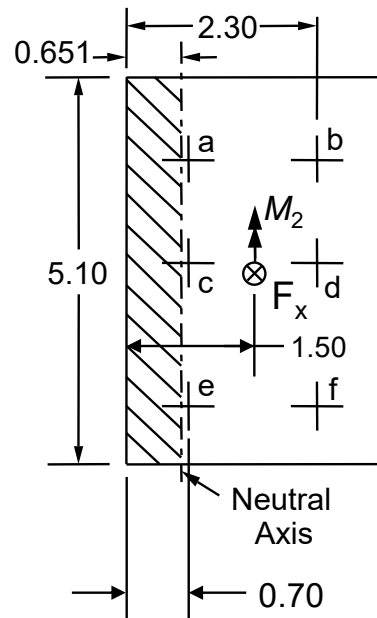

At the neutral axis, the moment,  $M_{2-na}$ , is increased by  $P_x$ :

$$M_{2-na} = M_2 + (1.50 - 0.651)P_x = M_2 + 0.849P_x$$

and the peak bolt tension is

$$P_t = 0.160(M_2 + 0.849P_x) + P_x \left[ \frac{\left( \frac{E_b}{E_f} \right) A_s}{5.10(0.651) + 6 \left( \frac{E_b}{E_f} \right) A_s} \right]$$

$$= 0.160M_2 + 0.136P_x + 0.046P_x$$

$$= 0.182P_x + 0.160M_2 \quad \text{as compared with } P_t = 0.167P_x + 0.160M_2 \text{ when we used inconsistent assumptions.}$$

$$E_b = 29 \times 10^6 \text{ psi}$$

$$E_f = 10.5 \times 10^6 \text{ psi}$$

$$A_s = 0.0767 \text{ in}^2$$

continued

## Example Problem 4-f, continued

It's even more revealing to look at the compression surface. With consistent assumptions, the resultant compressive load,  $P_c$ , is

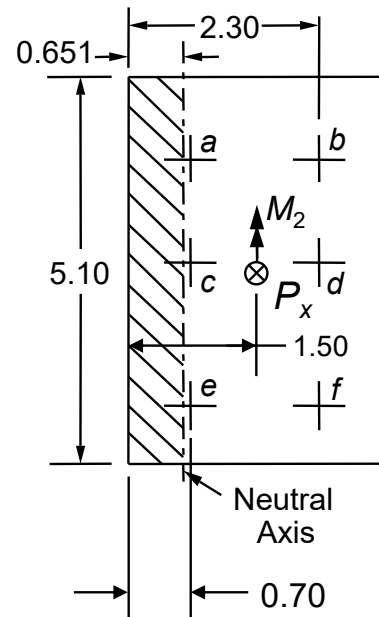

$$P_c = \frac{1}{2.08} (M_2 + 0.849P_x) - P_x \left[ \frac{5.10(0.651)}{5.10(0.651) + 6 \left( \frac{E_b}{E_f} \right) A_s} \right]$$

$$= 0.481M_2 + 0.408P_x - 0.723P_x$$

$$= -0.315P_x + 0.481M_2$$

- The axial force,  $P_x$ , relieves the compression.
- The compressive force goes to zero if the axial force exceeds about 1.52 times the applied moment—which means the loads can be carried only by the bolts:

$$P_t = \frac{P_x}{6} + \frac{M_2}{3(2.30 - 0.70)} = 0.167P_x + 0.208M_2$$

## Comparison of Calculated Bolt Loads for Example Problems 4-d and 4-f

Method 1:  $P_t = 0.167P_x + 0.208M_2$  (loads reacted by bolts only)

Method 2:  $P_t = 0.182P_x + 0.160M_2$  (heel and toe, with consistent assumptions)

Method 3 (invalid):  $P_t = 0.167P_x + 0.160M_2$  (heel and toe, inconsistent assumptions)

		Maximum calculated bolt tension (lb):		
$P_x$ (lb)	$M_2$ (in-lb)	Method 1: Bolts only	Method 2: Heel and toe	Method 3 (invalid): Inconsistent heel & toe
0	10000	2080	<b>1600</b>	1600
2000	8000	1998	<b>1644</b>	1614
4000	6000	1916	<b>1688</b>	1628
6000	4000	1834	<b>1732</b>	1642
8000	2000	<b>1752</b>	N/A	1656
10000	0	<b>1670</b>	N/A	1670

Method 3 is invalid (and unsafe) because it is based on inconsistent assumptions. Loads cannot distribute in this manner in a real joint.

→ When the critical failure mode has enough ductility, loads will find the strongest load path that satisfies the conditions for static equilibrium.

- Conclusions:**
- Use consistent heel-and-toe when applied moment dominates.
  - Use the bolts-only method when tension is significant.

## Example Problem 4-g

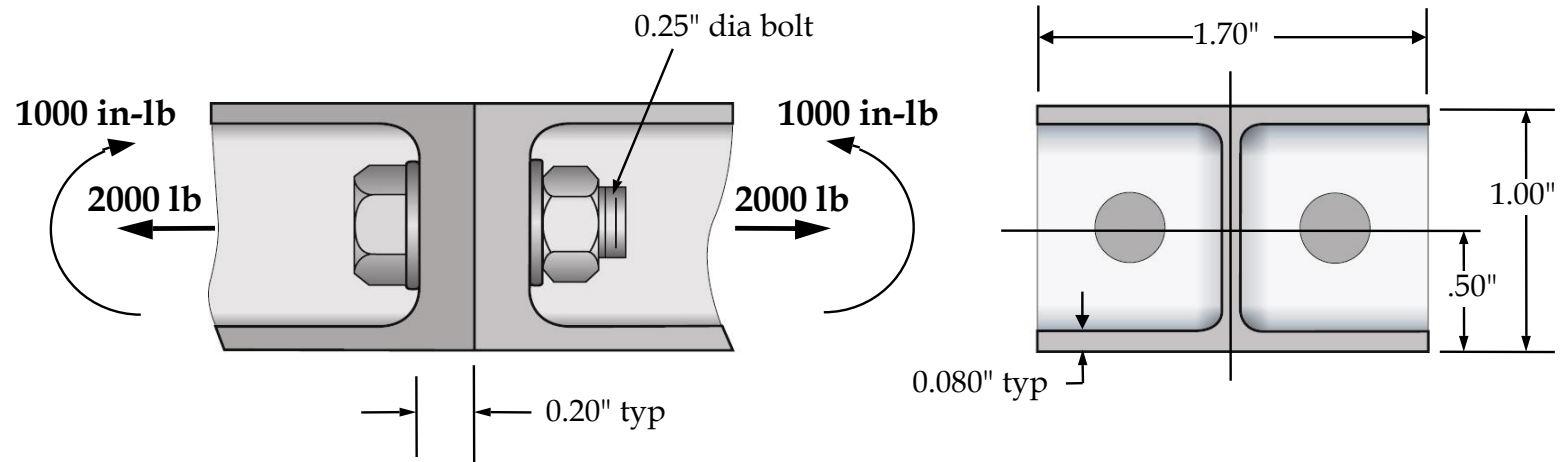

**Calculate or estimate the applied tensile load on each bolt.**

Assume the bolts themselves carry no bending moment.

continued

## Example Problem 4-g, conclusion

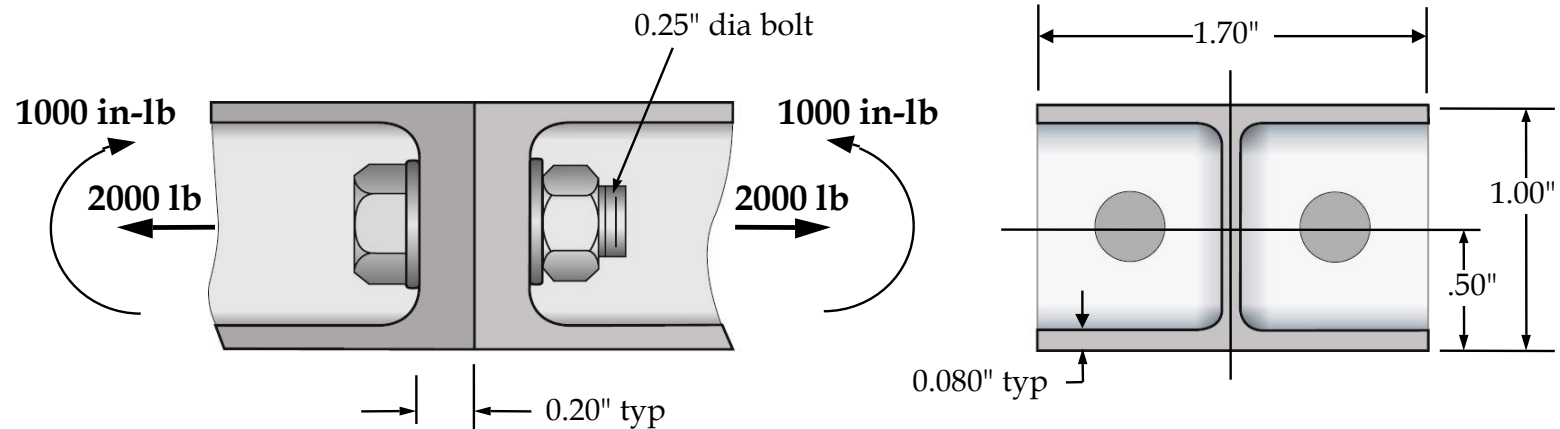

We're tempted to divide the 2000 lb axial load equally between the two bolts and add the extra bolt tension caused by the 1000 in-lb moment, which we compute with heel-and-toe analysis (locate the neutral axis), but our assumptions would not be consistent. In actuality, this joint would find a neutral axis, and loads would be reacted as shown below.

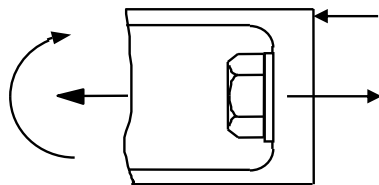

However, the applied tension adds to the moment about the neutral axis, and the joint becomes a lot more flexible in rotation than it would be if there were no applied tension. The joint acts more "pinned" than "fixed."

**If the joint must carry moment while under tension, this is not a good design!**

## Estimating Fastener Loads for Sheet-metal Skin Panels

Classical approach:

1. Compute panel running loads (force per unit length; e.g., lb/in).
2. Compute fastener loads as running load  $\times$  spacing.
3. Find the vector sum to compute peak fastener shear load.

**Caution: This method applies only when the critical failure mode is ductile (e.g., ductile panel materials and fasteners designed to be bearing critical rather than shear critical, as discussed in Sec. 5).**

## Classical Method of Computing Peak Fastener Shear for a Skin Panel

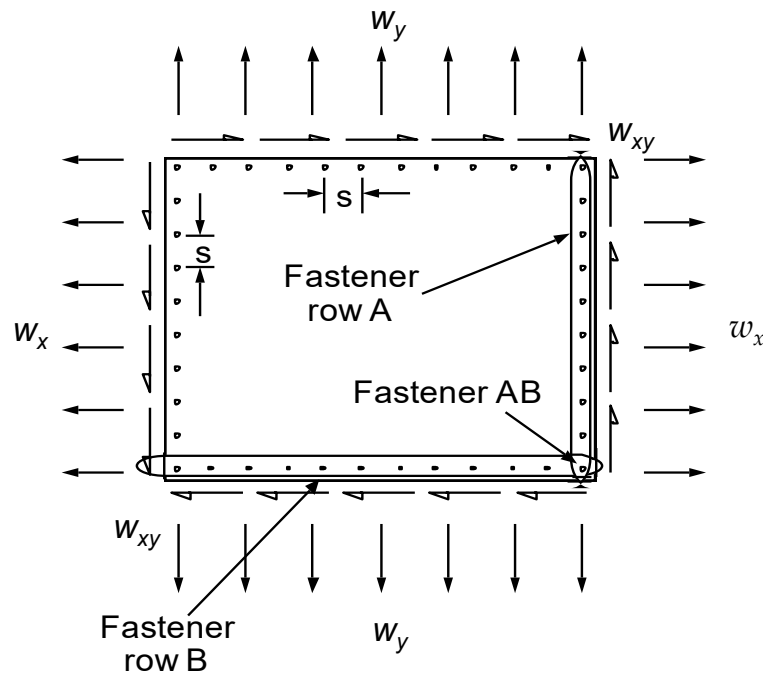

Running load,  $w$  = force per unit length (e.g., lb/in)

Fastener row A carries  $w_x$  and  $w_{xy}$ :

$$P_{Ax} = w_x s \quad P_{Ay} = w_{xy} s$$

Fastener row B carries  $w_y$  and  $w_{xy}$ :

$$P_{Bx} = w_{xy} s \quad P_{By} = w_y s$$

The highest load is on the corner fastener, AB:

$$P_{ABx} = w_x s + w_{xy} s$$

$$P_{ABy} = w_y s + w_{xy} s$$

Resultant fastener shear:

$$P_{ABs} = \sqrt{P_{ABx}^2 + P_{ABy}^2}$$

**See caution on previous page.**

## 5. Failure Modes and Assessment Methods

- Understanding Stress Analysis
- An Effective Process for Strength Analysis
- Bolt Tension and Shear
- Tension Joints
- Shear Joints
- Identifying Potential Failure Modes
- Bolted Shear Joints with Composite Materials

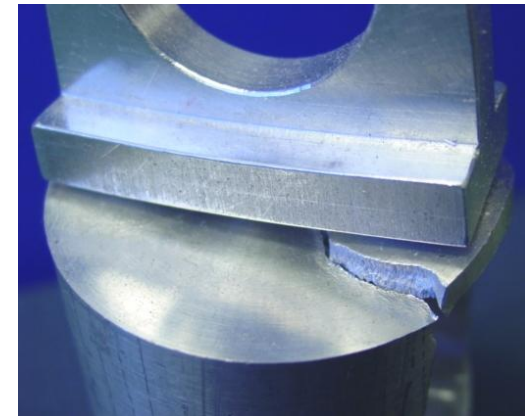

Permission is granted by Instar for anyone to freely copy, distribute, and print this material, but only in its unaltered form. This section may be separately copied or printed, but only in its entirety, including this page and with headers and footers intact. Unaltered individual figures and tables and portions of text may be copied or used, but only with text in quotes and with the following statement "Source: Design and Analysis of Bolted Joints (DABJ) course book, Thomas P. Sarafin, Instar Engineering and Consulting, Inc. Reproduced with permission." The date of last revision also should be included in the reference. If you have questions, contact [tom.sarafin@instarengineering.com](mailto:tom.sarafin@instarengineering.com).

## Objectives of Analysis

The general objective of analysis is to help understand a problem.

Specific objectives of analysis depend on the problem being addressed.

Regarding structural analysis of bolted joints,

- To the researcher or college professor, the objectives might be ...
  - To understand the state of stress in a particular part.
  - To understand how the tensile load in a preloaded bolt changes with applied load.
- To the engineer, the objectives are usually much different:
  - To ensure designed joints can withstand environments and applied loads and function as needed.
  - To make designs efficient.

**In this course, we will continue to view analysis from the engineer's perspective.**

## Understanding Stress Analysis from the Engineer's Perspective

from Instar's course "Spacecraft Structures, from Concept to Launch (SCS)"

**To the engineer, stress analysis is not about predicting stresses.  
It's about making designs efficient and avoiding failure!**

### ***Stress analysis:***

- Often thought of as the process of predicting stresses caused by applied loads
- Actually, to the engineer, it is a process of relating applied loads to allowable loads (or to allowable stresses, more often) in an apples-to-apples comparison
- Allowable stresses are derived from tests, but the stress itself is not measured.
  - Load is measured and then converted (by some process) to stress.

### **An apples-to-apples comparison means two things:**

- 1. The structural design and failure mode of concern correspond to those that were tested to derive the allowables.**
- 2. We use a method of converting load to stress that is consistent with the way in which the allowable stress was derived.**

**Apples to oranges is acceptable if we use an appropriate uncertainty factor.  
When it's apples to elephants, we won't know what factor to use!**

## The Best Approach to Strength Analysis for Metallic Joints

In regions of changing geometry and stress concentration, ductility invalidates linear-elastic analysis for ultimate strength.

Local yielding in high-stress regions causes loads to redistribute, which usually (but not always) increases strength. The state of stress itself changes.

Thus, linear-elastic FEA is an extremely limited tool for strength analysis when using ductile materials.

Even inelastic FEA is of limited use!

What failure theory would we use? The von Mises criterion applies to onset of yielding, not rupture.

**There is no failure theory that applies to ductile rupture for all part geometries.** How the stress state changes after local yielding begins is dependent on geometry.

**The best approach to strength analysis of parts and joints in which stress concentrates is to use empirical or semi-empirical methods, based on tests of specimens that are similar to the design being assessed.**

## An Effective Process for Strength Analysis

1. Start with a drawing or solid model of the structure.
  - You’re assessing a design, not a finite element model!
2. Identify the structural requirements.
  - How much can the structure permanently deform without adversely affecting function (e.g., alignment)?
3. Draw a free-body diagram.
  - Take time to understand the load paths.
4. Identify and envision potential failure modes.
  - **Ultimate failure** is rupture or collapse.
  - **Yield failure** is usually defined from step 2, above.
5. Identify or calculate appropriate allowables.
  - Allowable loads or stresses that correspond to the identified potential failure modes; empirically based.
  - Development testing may be necessary.
6. Predict design loads or stresses that correspond to the allowables.
  - Finite element analysis might be best.
7. Calculate margins of safety.

Improve design

Don't waste time analyzing a bad design!

Key steps!

Finite element analysis will predict loads and stresses, but the engineer must identify potential failure modes and appropriate allowables.

From Instar’s course “Spacecraft Structures, from Concept to Launch” (SCS)

## Failure Modes for Threaded Fasteners: Tension

The allowable ultimate tensile load,  $P_{tu\text{-allow}}$ , for a bolt is the minimum strength defined in the bolt's specification or procurement specification, which in most cases is ...

$$P_{tu\text{-allow}} = F_{tu} A_t \quad (\text{Eq. 5.1})$$

$F_{tu}$  = allowable ultimate tensile stress  
 $A_t$  = tensile stress area (at threads; see Sec. 2)

To count on this strength, the mating nut or insert must have a specified minimum strength that is at least this high. (See Sec. 6 for thread stripping when using tapped holes.)

Make sure you're using a bolt designed for tensile loading. If the head is too thin, it can fail at a load lower than that given by Eq. 5.1.

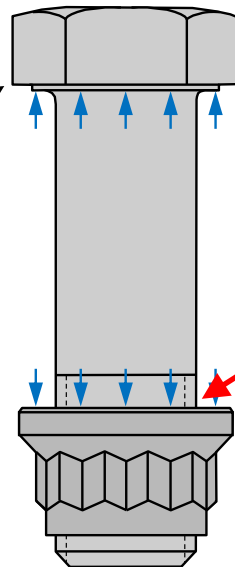

If the bolt is designed for tensile use and is matched with an appropriate nut or insert, ...

- the bolt normally ruptures through the threaded cross section before the threads strip,
- and the bolt will usually fail just outside the first engaged thread.

This is normally a ductile failure—to some extent.

## A Bolt that Failed in a Tension Test

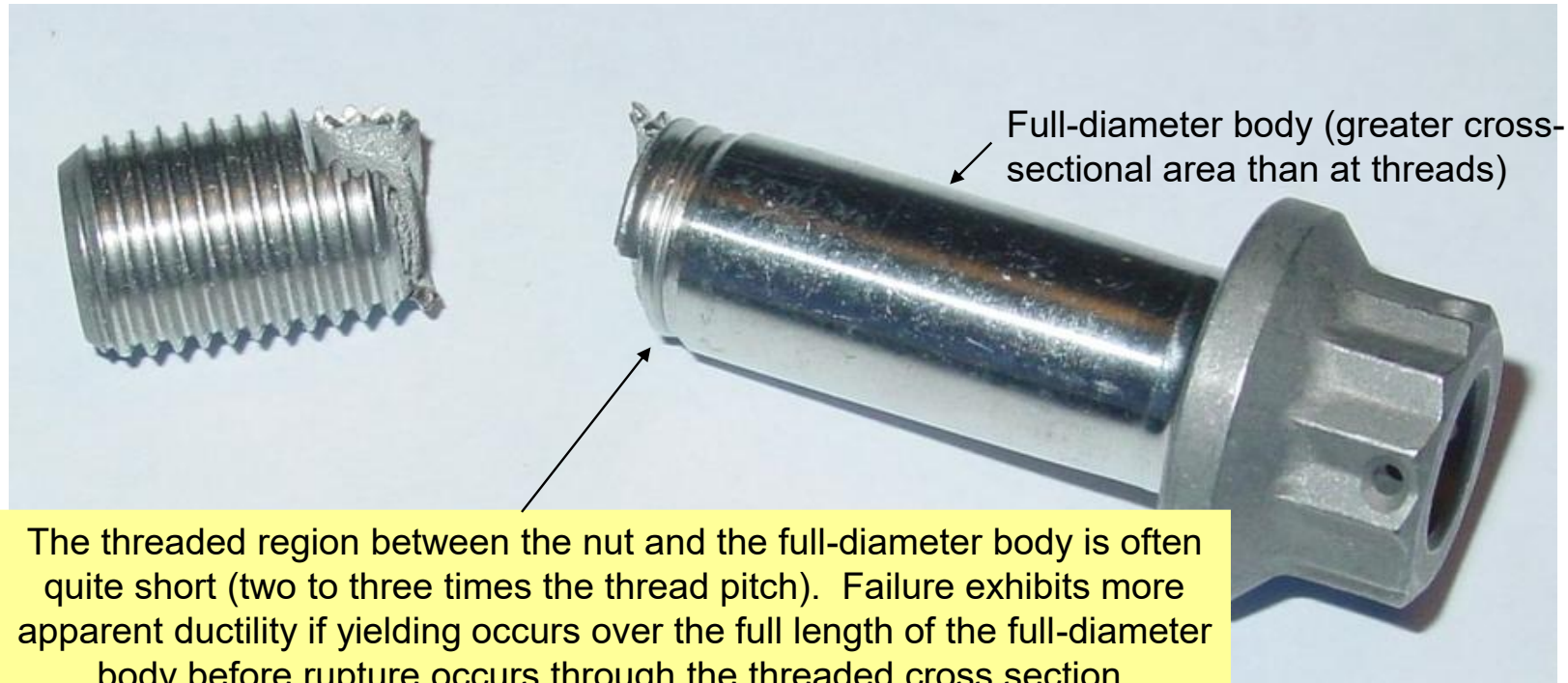

The threaded region between the nut and the full-diameter body is often quite short (two to three times the thread pitch). Failure exhibits more apparent ductility if yielding occurs over the full length of the full-diameter body before rupture occurs through the threaded cross section.

Thus, for tensile loading, a bolt with a full-diameter body should be made of a material that has a yield strength that is no more than about 75 - 80% of its ultimate strength, such as 160-ksi A-286 (a.k.a. A286), for which  $F_{ty} = 120$  ksi. This is not the case with ultra-high-strength fasteners and 160-ksi titanium fasteners.]

**These bolts have little plastic displacement before rupture.**

## Bolt Shear Strength—Threads Not in Shear Plane or in Bearing

If the full-diameter body is in the shear plane, the allowable ultimate shear load per shear plane is

$$P_{su\text{-allow}} = F_{su} A_s = F_{su} \left( \frac{\pi D^2}{4} \right) \quad \text{(Eq. 5.2)}$$

NASA-STD-5020B Eq. 12)

$F_{su}$  = allowable ultimate shear stress  
 $A_s$  = full-diameter shear area  
 $D$  = nominal bolt diameter

**Caution: I recommend using this equation only if no more than one thread (or runout thread) is in bearing because failure can occur through the threaded cross section (see next page) when threads get close to the shear plane.**

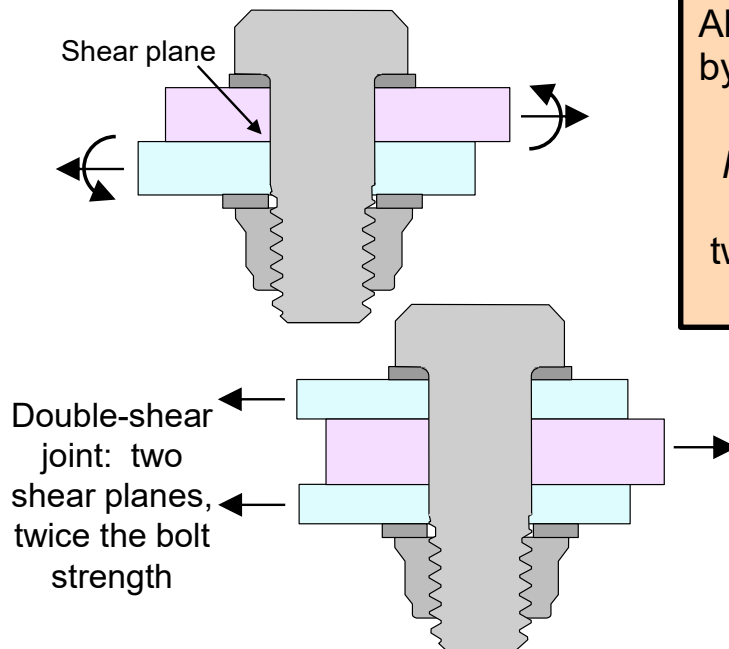

Although Eq. 5.2 is traditionally accepted in industry (and by NASA-STD-5020B) for single-shear joints, it's actually not apples-to-apples with test data.

$F_{su}$  is typically derived from double-shear tests of solid cylinders (pins), calculated as failure load divided by twice the pin's cross-sectional area. The state of stress in the fastener is more complex for single shear.

**Tests at Marshall Space Flight Center (Ref. 42) suggested that Eq. 5.2 (12) may over-predict strength by about 5%. After discussing this observation, the 5020 team decided to accept the equation as it appears above (one of the reasons for a fitting factor!).**

**Additional testing is warranted.**

## Bolt Shear Strength—Threads in Shear Plane or in Bearing

If the threads are in the shear plane:

$$P_{su\text{-allow}} = F_{su} A_m \quad (\text{Eq. 5.3})$$

(NASA-STD-5020B Eq. 13, based on tests conducted at NASA Marshall Space Flight Center, Ref. 42)

where  $F_{su}$  = allowable ultimate shear stress  
 $A_m$  = minor-diameter area (see Sec. 2)

I also would use this equation for a floating fastener that has a full-diameter body if more than one thread (or runout thread; see Sec. 7) is in bearing. When threads get close to the shear plane, failure can occur at the threads.

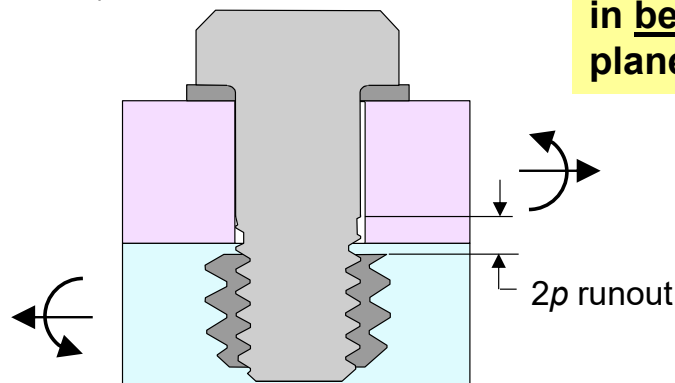

Avoid tapped holes and inserts for high-shear applications. Use a shear pin or other such feature if friction won't reliably carry the load.

In the Ref. 42 test, bolts from the procurement lot were tested to failure in single shear, with threads not in the shear plane.  $F_{su}$  was derived from test results using Eq. 5.2, and that value of  $F_{su}$  was then used to derive Eq. 5.3.

Thus, if Eq. 5.2 is somewhat unconservative, so is Eq. 5.3.

We'll address in Secs. 8 and 9 the effects of preload combined with applied tension, bolt yield analysis, and interaction of tension, shear, and bending.

## Potential Failure Modes for Tension Joints

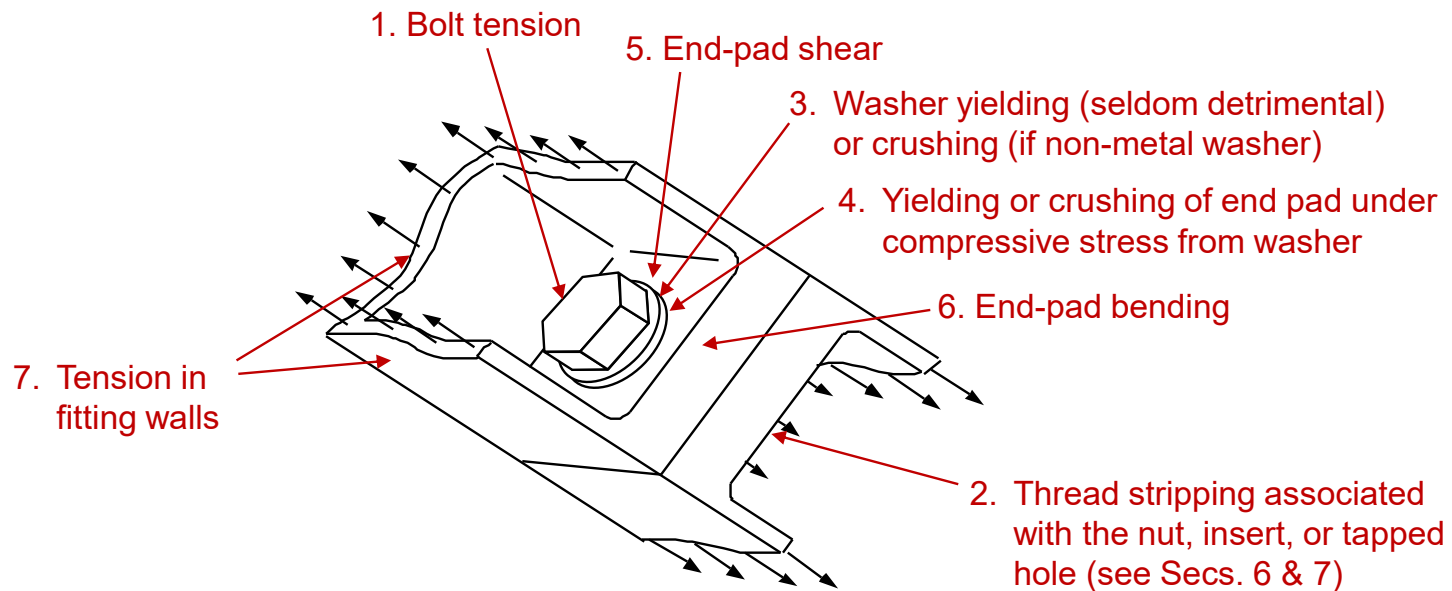

### Design guidelines:

- Select a nut or an insert that is at least as strong as the bolt (reduces risk of relatively brittle failure or of the analyst forgetting to check the nut or insert).
- Make the end pads thick enough to avoid bending and shear failures.
- Tuck the bolt close to the tension walls to reduce end-pad bending, hence thickness, and make the joint stiff.

## Assessing End-Pad Bending and Shear

Up until the late 1990s, Lockheed Stress Memo 88a was commonly used throughout the aerospace industry.

- Semi-empirical; developed in the 1950's
- Marked “Proprietary” to Lockheed, unfortunately!
- Even if it weren't proprietary, we wouldn't be able to independently assess this method because actual test data and method derivation are not available.

When I asked in 1992, Lockheed would not give permission to publish this method in the open domain.

- Liability concern

The book *Airframe Stress Analysis and Sizing* (ref. 17) presents a method that resembles the 88a method but is simpler.

- However, no basis given; clearly derived from 88a
- Very limited; compares favorably with 88a only when severe geometry constraints are met
- Use with caution

**The aerospace industry needs a publically available, test-substantiated method of analysis for tension-type fittings. Additional testing is warranted.**

**As stated previously in this section, FEA does not apply to ductile rupture for bolted joints.**

## Example of End-pad Yield in a Tension Joint

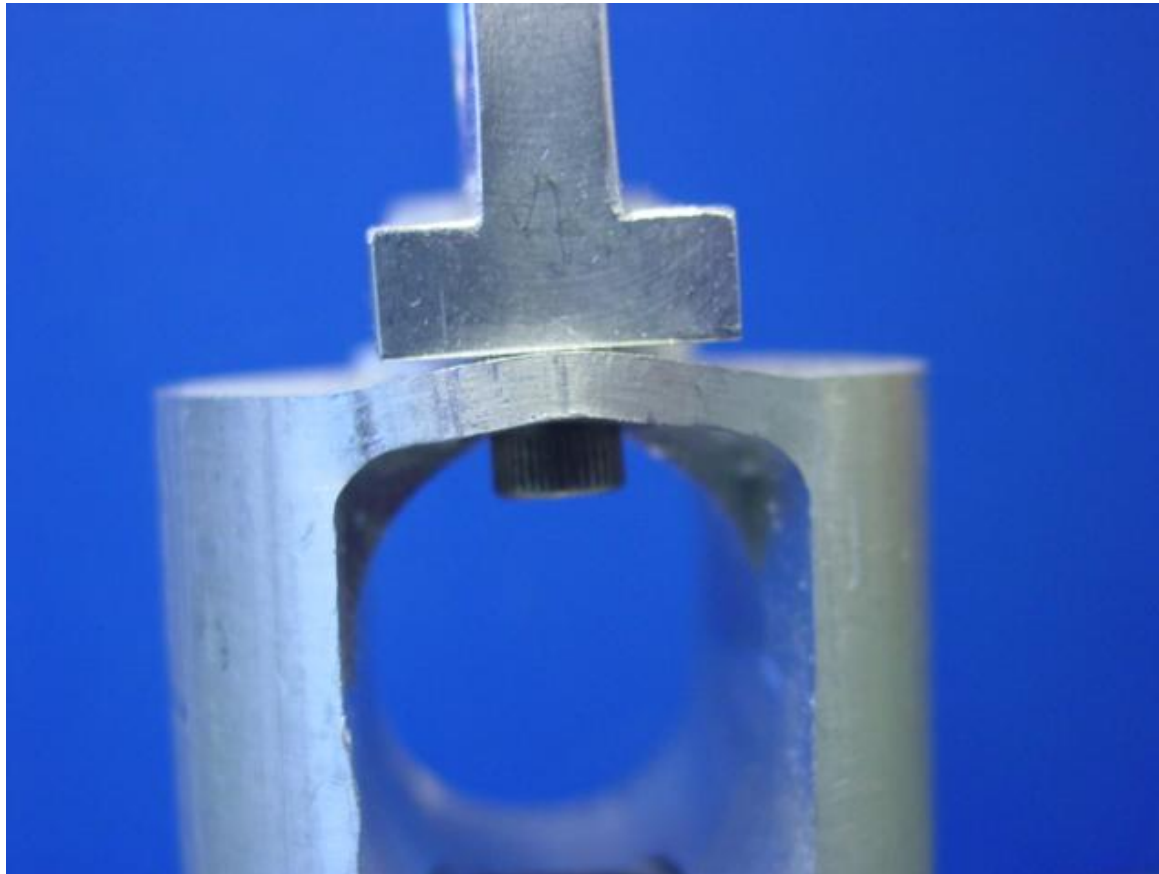

## An End Pad Can Rupture in Shear

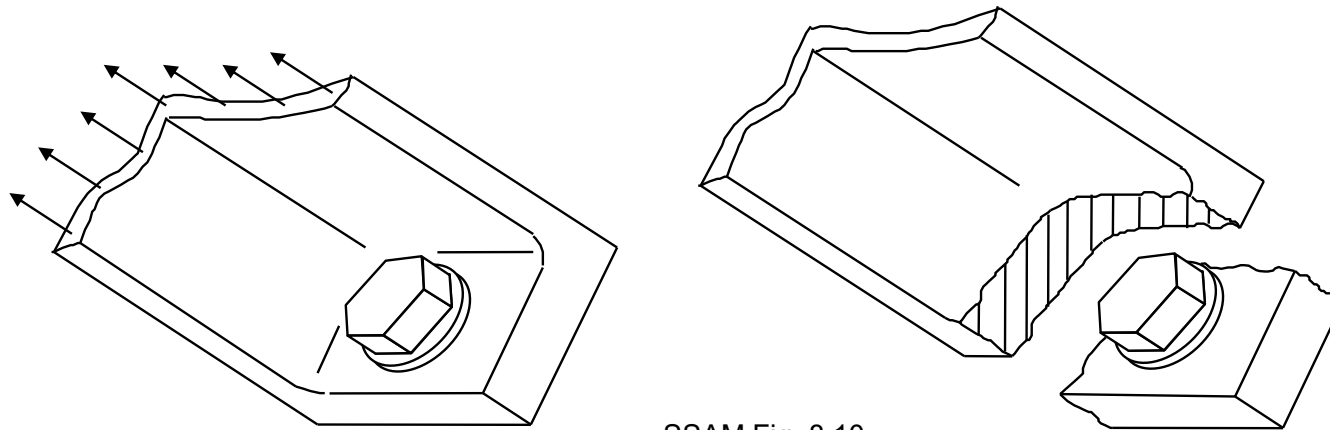

SSAM Fig. 8.10

In absence of an empirical method, a conservative method of estimating the allowable load for end-pad shear, for the joint shown above, is to multiply the allowable shear stress by an effective shear area that is equal to thickness multiplied by half the circumference of the bolt-head (or circular washer face for the bolt head).

**This method is conservative for end-pad shear but is not necessarily on the safe side for end-pad bending.**

## Example of Ultimate Shear Failure in an End Pad

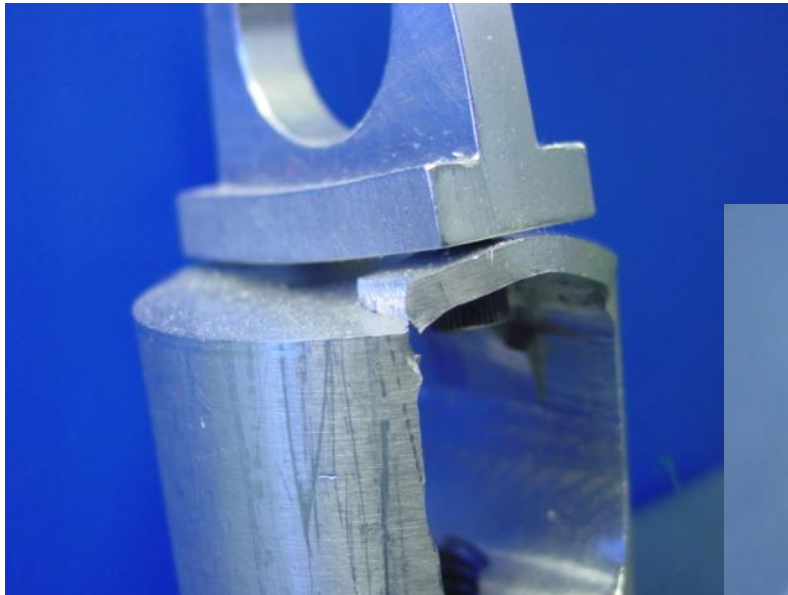

Material: 6061-T6 aluminum alloy

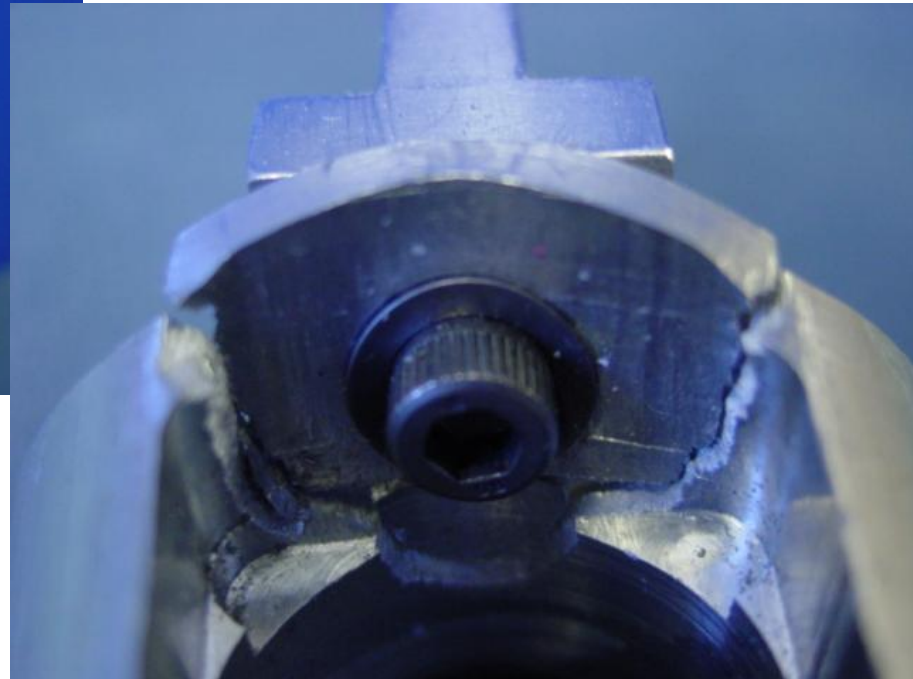

## Example of How Ductility Can Improve Ultimate Strength

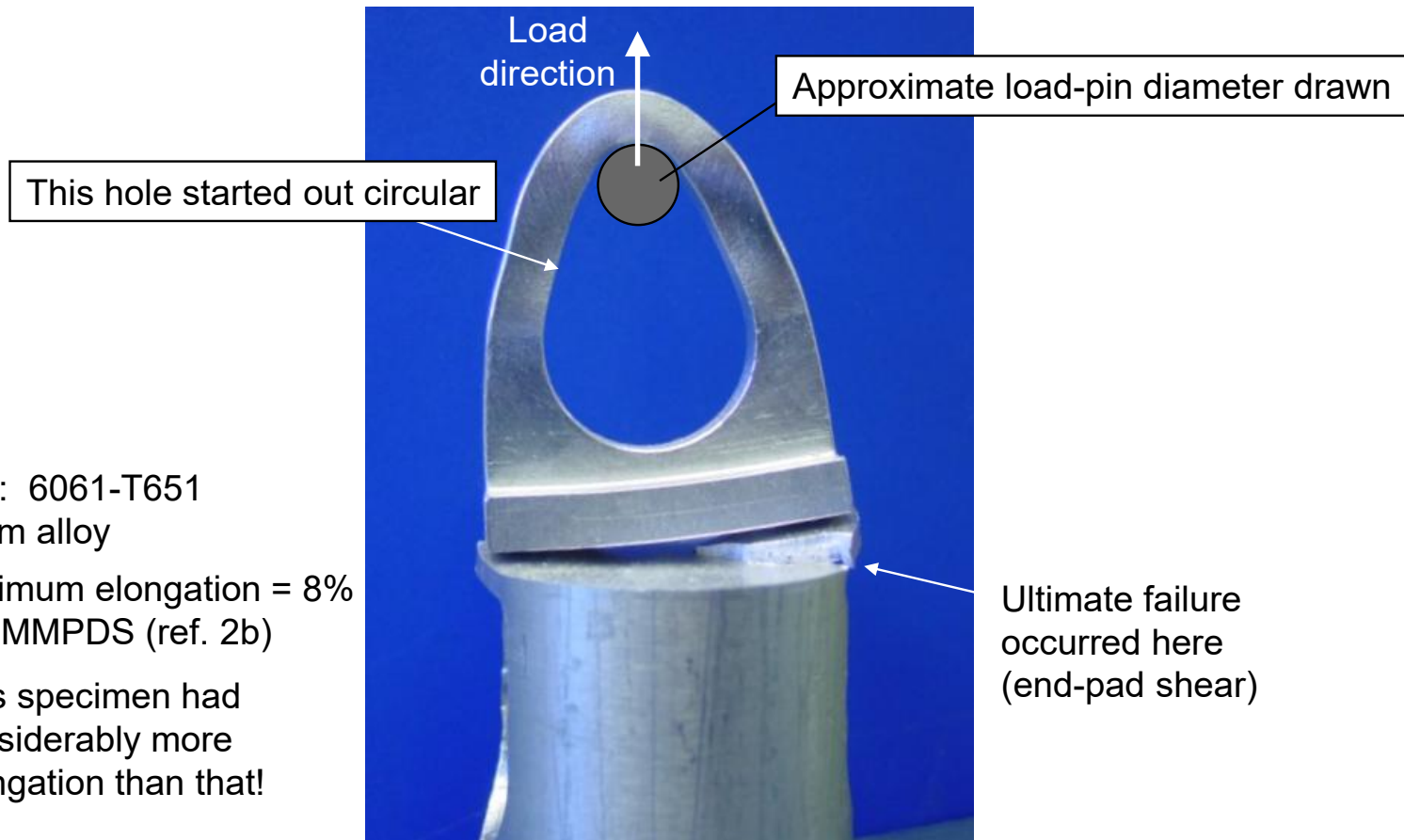

Material: 6061-T651  
aluminum alloy

- Minimum elongation = 8% per MMPDS (ref. 2b)
- This specimen had considerably more elongation than that!

## Strength Test of a Tension Joint

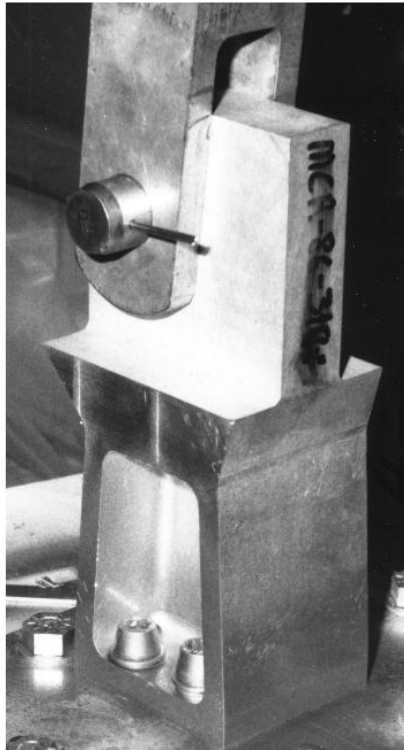

Material: 2219-T87 aluminum alloy

The end pad ruptured in shear, then failure propagated.

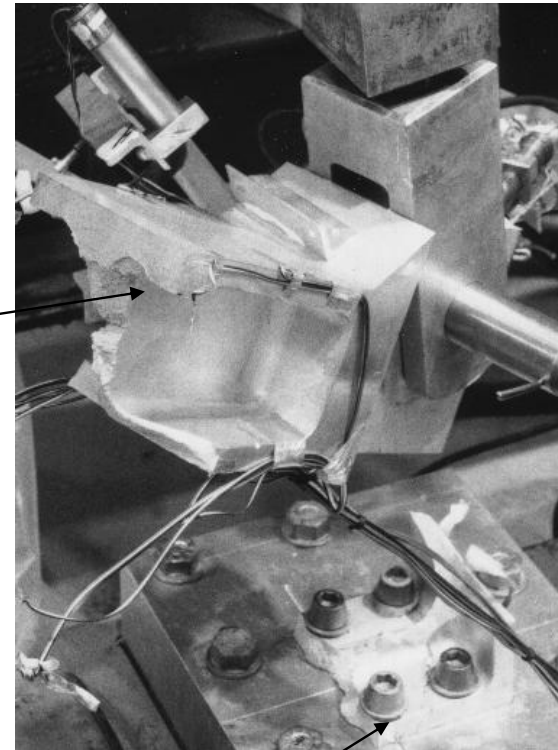

Well before the end pad failed in shear, it ruptured locally from the edge of the hole to the edge of the part, causing load to redistribute.

## Insert Failure

Two commonly used types of threaded inserts:

- Solid bushing-style inserts (e.g., Keenserts®)
  - Helical wire inserts (e.g., Heli-Coils®)
- ← compared in Sec. 7

Common failure mode: thread stripping

- Bolt to insert: normally the bolt threads fail
  - Must have adequate engagement in insert
  - Make sure the specified minimum strength of the insert is high enough for your application—and preferably at least as high as the bolt's minimum tensile strength.
- Insert to fitting: normally the fitting material fails
  - Solid metallic fittings: pull-out strength based on effective shear-engagement area and fitting-material shear strength.
  - Sandwich panels: pull-out failure mode and strength depend on configuration, materials, and process variables. Do your own tests to establish allowables.

**Most inserts have two strength values to check: (1) pull-out strength, which depends on the parent material, and (2) load rating, which is independent of parent material and is given in the insert spec or the procurement spec as a required minimum strength.**

**We'll investigate thread stripping and pull-out strength in Sec. 6.**

## Potential Failure Modes for Shear Joints

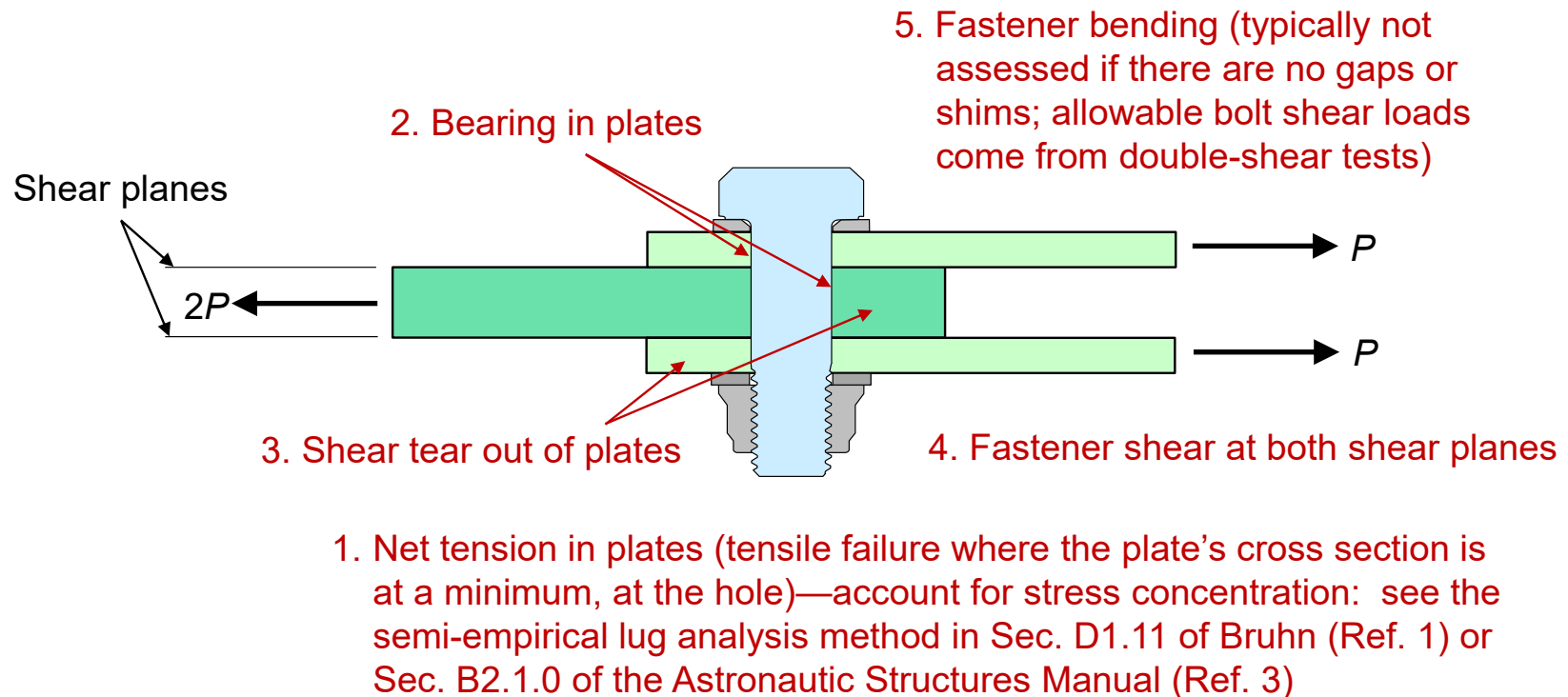

**Joint slip under the design yield load may be considered failure as well if friction is being counted on (e.g., to maintain alignment of critical interfaces)**

## Bearing Stress

For a double-shear joint without shims, **bearing stress**,  $f_{br}$ , is calculated as the average contact stress between the fastener body and the surface of the hole:

$$f_{br} = \frac{P_{br}}{Dt} \quad \leftarrow \text{Bearing load acting on a plate} \quad \text{(Eq. 5.4)}$$

Given an allowable bearing ultimate stress,  $F_{bru}$ , the allowable bearing ultimate load is

$$P_{bru\text{-allow}} = F_{bru}Dt \quad \text{(Eq. 5.5)}$$

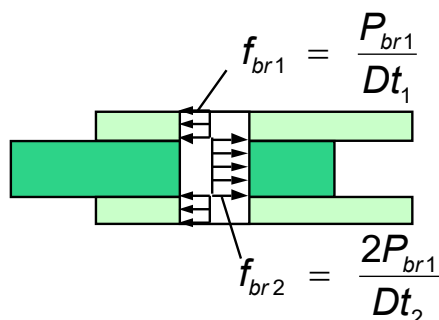

Assumed distribution of contact pressure

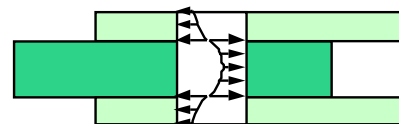

Actual distribution of contact pressure

$D$  = bolt or pin diameter  
 $t$  = plate thickness

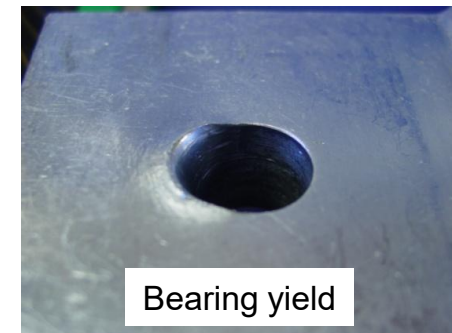
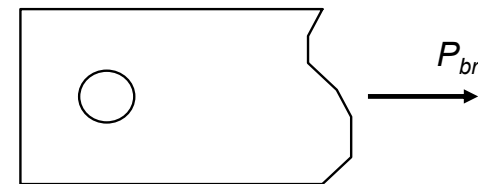

## Bearing and Shear Tear Out

Reference 2b (MMPDS) provides allowable yield and ultimate bearing stresses,  $F_{bry}$  and  $F_{bru}$ , for  $e/D = 2$  and  $e/D = 1.5$

- For  $1.5 < e/D < 2$ , interpolate to find the allowable (per MMPDS).

Shear tear-out of plates is typically encompassed by ultimate bearing-strength analysis when  $e/D \geq 1.5$

- For  $e/D > 2$ , use allowables for  $e/D = 2$
- For  $e/D < 1.5$ , the following methods (both considered conservative with use of a 1.15 fitting factor) have been used:
  1. Define an equivalent lug, as shown at right, and analyze it using the semi-empirical lug-analysis method in Bruhn (ref. 1) Sec. D1.11 and the Astronautic Structures Manual (ref. 3) Sec. B2.1.0.
  2. Derive an allowable bearing stress by interpolating between the  $e/D = 1.5$  allowable and zero at  $e/D = 0.5$ .

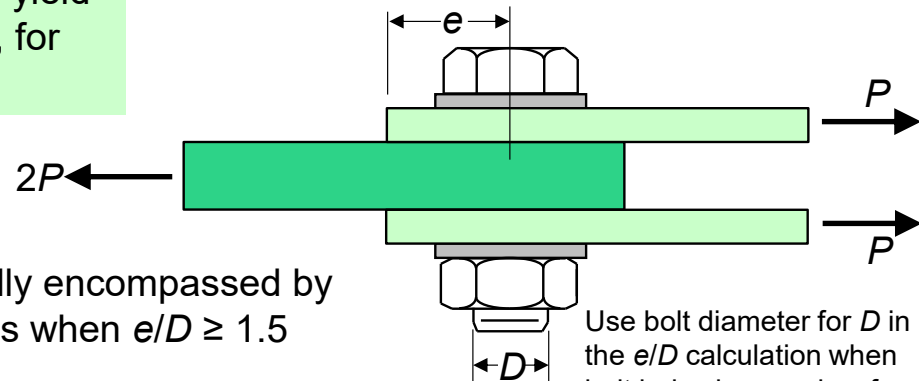

Use bolt diameter for  $D$  in the  $e/D$  calculation when bolt holes have only a few thousandths of an inch clearance; for larger holes use bolt-hole diameter.

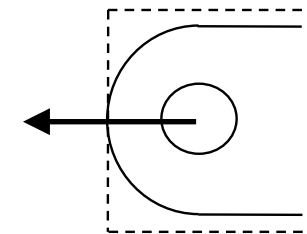

## Applicability of MMPDS Bearing Allowables

- Bearing allowables apply only for double-shear joints.
  - Testing per ASTM E238 puts the pin in double shear.
  - Higher bearing-stress peaking occurs in single-shear joints.
- Bearing allowables from MMPDS-08 (Ref. 2b) apply only when the ratio of plate thickness to bolt diameter ( $t/D$ ) is between 0.25 and 0.50.
  - The limitation used to be  $0.18 \leq t/D \leq 1.00$  (Ref. 2a, MIL-HDBK-5H, 1998).
  - It presumably changed in MMPDS as a result of additional test data.
- MMPDS-08 Sec. 1.4.7 says “Due to differences in results obtained between dry-pin and wet-pin tests, designers are encouraged to consider using a reduction factor with published bearing stresses for use in design.”
  - Tests are done per ASTM E238, with specially cleaned (“dry”) pins.
  - Tests with pins not cleaned per this process (“wet” pins) “can show bearing (strengths) at least 10% lower” (MMPDS-08 Sec. 1.4.7).
- The tests are conducted without shims, which can concentrate bearing stresses at the mating surfaces and reduce joint strength.

## Bearing Margins of Safety

For a joint that meets the limitations for which bearing allowables apply and is not alignment critical (see related discussion on the following pages), bearing margins of safety are calculated for yield and ultimate as follows:

$$MS_y = \frac{F_{bry}}{f_{bry}} - 1$$

$$MS_u = \frac{F_{bru}}{f_{bru}} - 1$$

where

$F_{bry}$  = allowable bearing yield stress

$F_{bru}$  = allowable bearing ultimate stress

$f_{bry}$  = design yield bearing stress =  $FF_y \cdot FS_y \cdot f_{br}$

$f_{bru}$  = design ultimate bearing stress =  $FF_u \cdot FS_u \cdot f_{br}$

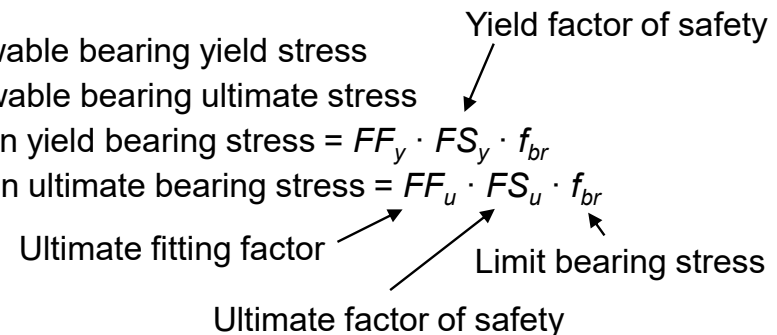

For a joint that does not meet the limitations for which bearing allowables apply, either (a) develop applicable allowables by test or (b) make conservative assumptions or reduce the available allowables by an appropriate knockdown factor to account for uncertainty.

- Without applicable test data, all stakeholders should have a vote on what knockdown factor is “appropriate”.

**Additional testing is warranted.**

## Understanding Bearing “Yield”

Typical (hypothetical) results of a shear-joint test:

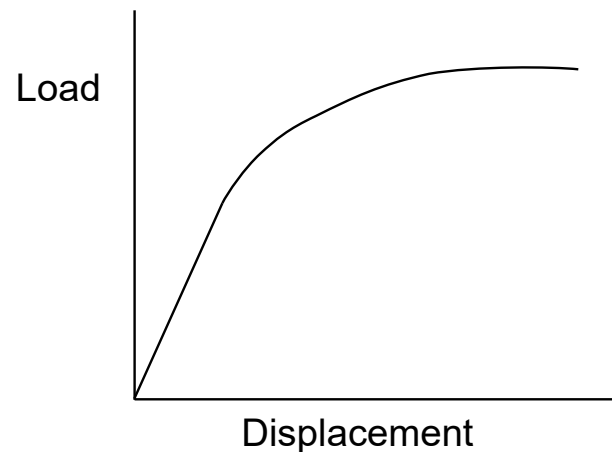

With data like this, how would you define “yield”?

**How much permanent displacement corresponds to the allowable bearing yield stress,  $F_{bry}$ , from MMPDS?**

## Fastened Shear Joints in Alignment-Critical Applications

Bearing yield allowables correspond to permanent displacement equal to 2% of the pin or bolt diameter for a given plate (4% if yielding occurs in plates on both sides of the joint).

- Example: for a ¼”-dia bolt, 4% is 0.010”
- Can your structure (or mechanism) still function properly with this much permanent deformation?
- Unless you do your own tests, you won’t know an allowable stress that corresponds to less deformation than that.

With the same materials and plate thicknesses, a single-shear joint will suffer permanent deformation at a load that can be surprisingly low. Bearing allowables are based on tests with the pin in double shear.

- Unless you do your own tests, for a single-shear joint you won’t be able to determine a dependable allowable yield load when calculating bearing stress with Eq. 5.4.
- Shims reduce yield strength even further. (How much? You won’t know without relevant test data.)

**If you must use fastened shear joints in alignment-critical structures, either design them as friction joints or do early development tests to determine appropriate allowables.**

## Example Problem 5-a: Allowable Load for a Shimmed Single-Shear Joint

Calculate the allowable yield load ( $P_{y\text{-allow}}$ ) and the allowable ultimate load ( $P_{u\text{-allow}}$ ).

5/8" dia. bolt, full-diameter body in shear plane, no threads in bearing

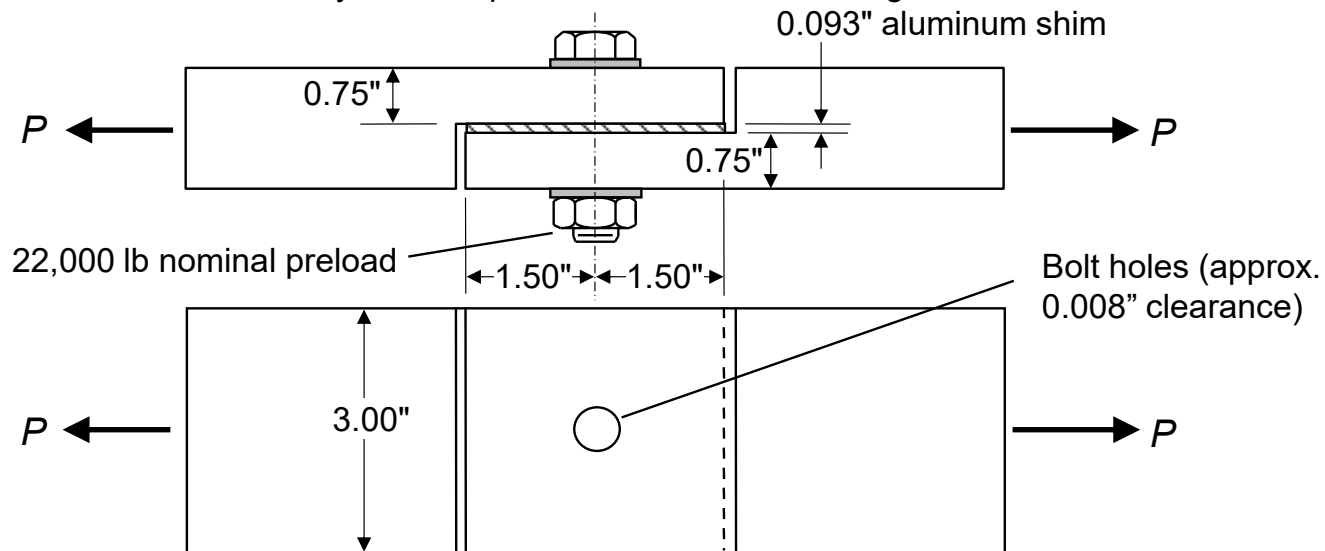

Fastener material: A-286 alloy

$$F_{ty} = 120 \text{ ksi}$$

$$F_{su} = 95 \text{ ksi}$$

$$F_{tu} = 160 \text{ ksi}$$

Fitting material: Aluminum alloy;

$$F_{ty} = 49 \text{ ksi}$$

$$F_{bry} = 94 \text{ ksi (for } e/D = 2)$$

$$F_{tu} = 62 \text{ ksi}$$

$$F_{bru} = 123 \text{ ksi (for } e/D = 2)$$

Edge-distance ratio

A-basis allowable bearing stresses

continued

## Example Problem 5-a, continued: Single-shear Joint with Shim

This joint violates all the conditions for which allowable bearing stresses apply:

- Single shear rather than double shear
- Shim
- Plates much thicker than half the bolt diameter

**In classes taught between 1996 and 2010, I asked approximately 1000 aerospace structural engineers to calculate allowable loads for this joint.**

**Answers: calculated allowable ultimate loads ranged from 2000 lb to 90,000 lb!**

**We can reliably assess a joint only if the analysis is based on meaningful test data!**

continued

## Example Problem 5-a, continued: Test Setup

We tested this joint at Martin Marietta in the mid 1980s, but not with enough variables or specimens to establish statistically appropriate allowable loads or to derive an empirical method of analysis for shimmed single-shear joints.

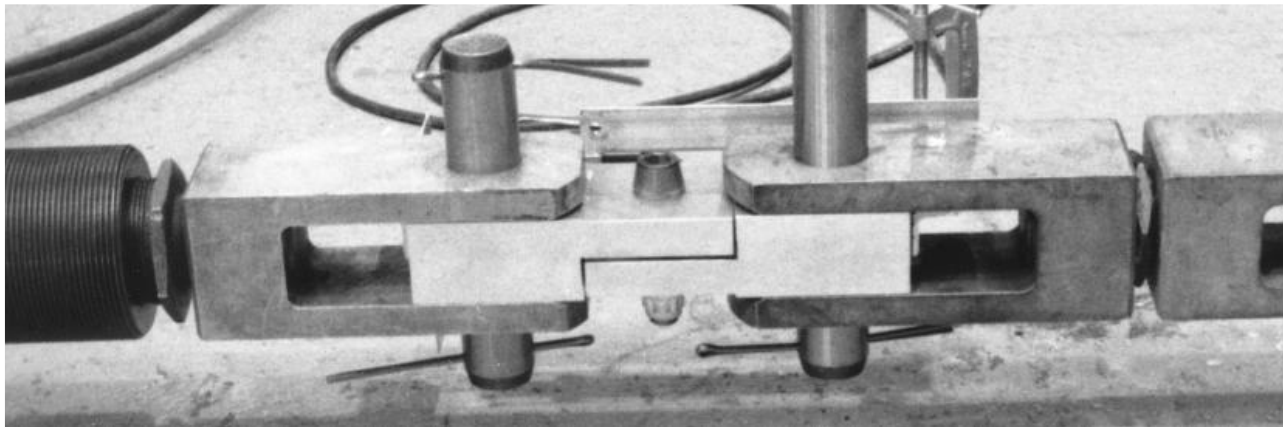

Not shown (far side): LVDT to measure displacement from one part to the other

LVDT = linear variable differential transformer

continued

## Example Problem 5-a, conclusion: Test Results

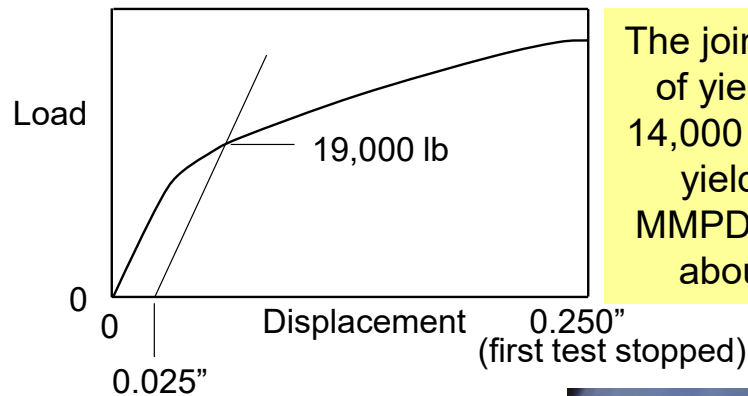

The joint saw an onset of yielding at about 14,000 lb and suffered yield failure (per MMPDS definition) at about 19,000 lb.

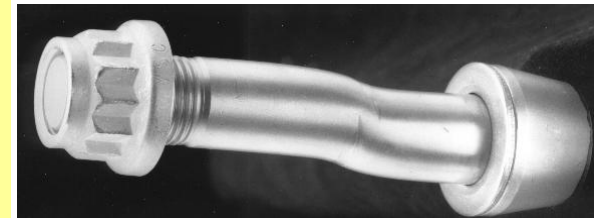

Bent bolt from first test

The second test was run to failure. The joint carried an ultimate load of 35,500 lb.

As compared with 29,100 lb calculated allowable shear load for the bolt using Eq. 5.2!

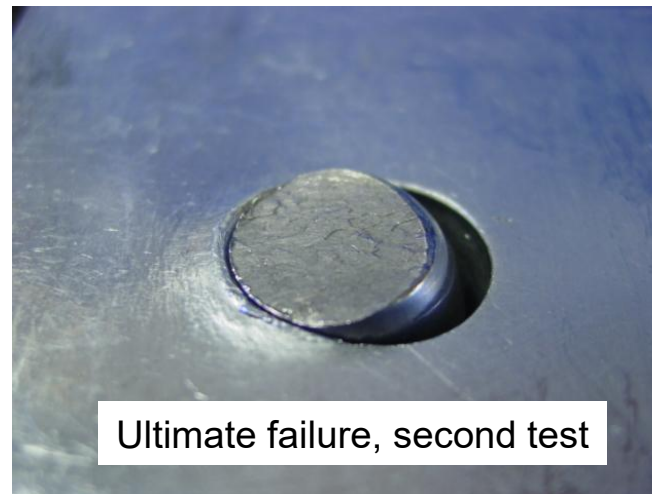

Ultimate failure, second test

Section 9 herein proposes a method of assessing certain shear joints, based on tests at Marshall Space Flight Center.

## Design Guidelines for Shear Joints

- When practical, make the joint double shear rather than single shear to reduce local bending effects and to provide twice the bolt shear strength.
- If you must go with a single-shear joint in an alignment-critical assembly, ...
  - design it to be a friction joint (no slip at the design yield load—discussed in Sec. 9),
  - or keep high margins and use conservative assumptions when assessing bearing and bolt bending,
  - or perform tests to determine appropriate allowable loads.
- To maximize bearing strength, make the edge-distance ratio,  $e/D$ , at least 2.0.
  - Rule of thumb: Avoid  $e/D < 1.5$  in design.
- Make fastener spacing at least  $4D$  (ref. 18, Niu).
- Avoid cyclic slip within clearance bolt holes by doing at least one of the following:
  - Design the joint to carry limit shear load by friction.
  - Use shear pins
  - Minimize bolt-hole clearance.
    - Consider match drilling and reaming, but design to enable these processes at low levels of assembly. Match-drilling at high-levels of assembly can be expensive and risks contamination.
    - See appendix to Sec. 7 for guidance on hole size.
- Make the joint bearing critical. (See next three pages.)

## Fasteners Don't All Carry the Same Shear Load

Even if a joint has tight bolt holes (or interference-fit rivets), some fasteners elastically carry more loads than others.

Example: If the bolts shown below were to elastically share the load  $P$  equally ...

Same materials, outer plates each half as thick as the inner plate

... there would be four times the elastic displacement between the two left-most bolts in the inner plate ...

...as there is in the outer plates ...

...which would cause the fasteners to deform as shown... which is not going to happen!

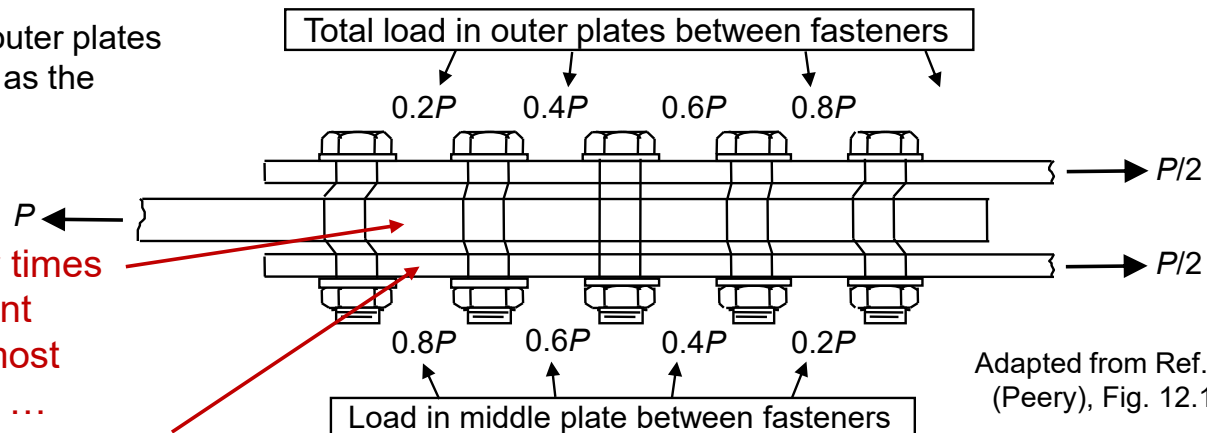

Adapted from Ref. 35 (Peery), Fig. 12.18

In this joint, the two end fasteners want to take all the load so the inner and outer plates have the same displacement between fasteners.

The internal fasteners carry load only to the extent caused by deformation of the highest-loaded bolts and holes (bearing).

## Bearing Ultimate Failure for Ductile Materials



The material can undergo very large plastic deformation, elongating the hole.

Ultimate failure is typically shear tear out.

## When the plates are made of ductile materials, Design Shear Joints to Be Bearing Critical

**Shear-critical joint:** one that has a lower margin of safety for fastener shear than for bearing.

- Can have little plastic deformation before ultimate failure.
- The highest-loaded fasteners can fail before the others take their share of load.
- Result: the joint can “unzip”, as each fastener next to a failed one becomes overloaded and then also fails.

**Bearing-critical joint:** one that has a lower margin of safety for bearing than for fastener shear.

- Bearing failure in ductile materials exhibits more plastic deformation than bolt shear failure, so the bolts share load before failure occurs at the highest loaded bolt.
- Bearing failure in brittle materials shows little deformation prior to rupture, so it doesn't help to make the joint bearing critical.

**Design a joint to be bearing-critical by increasing fastener diameter relative to plate thickness.**

**Even if the joint is bearing-critical, avoid long strings of fasteners in a splice, such as the one shown on the previous page.**

## Example Problem 5-b: Is this a bearing-critical joint or a shear-critical joint?

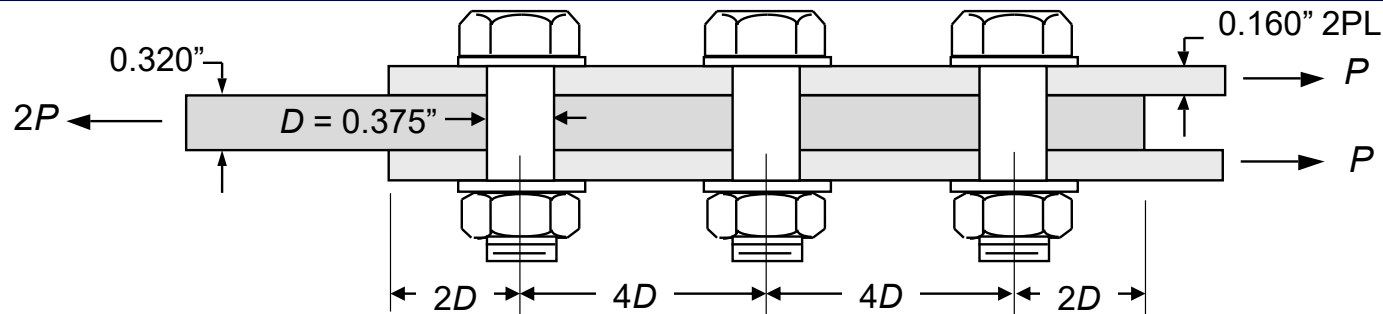

Bolt: A-286 alloy  $F_{su} = 95$  ksi      Plates: Aluminum alloy  $F_{bry} = 94$  ksi (for  $e/D = 2$ )  
 $F_{bru} = 123$  ksi (for  $e/D = 2$ )

### Solution:

1. Calculate the allowable shear ultimate load,  $P_{su\text{-allow}}$ , per bolt and per shear plane:

$$\text{Shear area, } A_s = \frac{\pi(0.375)^2}{4} = 0.1104 \text{ in}^2 \quad P_{su\text{-allow}} = F_{su} A_s = 95,000(0.1104) = 10,500 \text{ lb}$$

$$\text{Total allowable shear ultimate load per bolt with two shear planes} = 2P_{su\text{-allow}} = 21,000 \text{ lb}$$

2. Calculate the allowable bearing ultimate load,  $P_{bru\text{-allow}}$ , per bolt:

The middle plate has twice the load and is twice as thick as the outer plates:

$$P_{bru\text{-allow}} = F_{bru} D t = 123,000(0.375)(0.320) = 14,800 \text{ lb} < 21,000 \text{ lb}$$

**Therefore, the joint is bearing critical**

Note that we should not count on bearing strength of 14,800 lb because the  $t/D$  ratio exceeds MMPDS limits and we didn't reduce the "dry pin" allowable to account for a "wet pin".

## **How Important Is Bearing Criticality for High-strength Bolts Used with Aluminum Joint Members?**

- As noted, shear failure of a bolt—when there is no plastic deformation in bearing—can have little associated displacement.
- But, when using ductile materials, there is always some amount of plastic deformation in bearing before the fastener fails in shear.
  - Typically more plastic deformation in single-shear joints than in double-shear joints
- It takes a lot of load to break a high-strength bolt in shear.
  - As the bolt deforms under load, bearing stress peaks at the faying surfaces.
  - With aluminum joint members, there will be more plastic deformation in bearing at the faying surfaces than, say, if aluminum rivets were to attach steel parts.

**So, to ensure load is shared between bolts, do we really need to make joints bearing critical when using high-strength bolts and aluminum joint members?**

**We should answer this question in the test lab.  
In absence of such testing, though, we should be on the safe side of uncertainty—but not excessively so.**

## Suggested Fitting Factors for Single-shear Joints with High-strength Bolts and Aluminum Joint Members

Suggested fitting factors for assessing ultimate strength of single-shear joints with high-strength (such as A-286) bolts and aluminum plates

No more than two bolts in line with the applied shear load

Maximum hole diameter, $D_{h-max}$ :	< 1.05D	1.05D to 1.08D	1.08D to 1.12D
Bearing critical	1.15	1.15	1.15
Shear critical	1.5	2.0	2.5

Three or four bolts in line with the applied shear load

Maximum hole diameter, $D_{h-max}$ :	< 1.05D	1.05D to 1.08D	1.08D to 1.12D
Bearing critical	1.15	1.15	1.25
Shear critical	2.0	2.5	see example

These suggested factors are based solely on my judgment, in absence of test data.

**Example Problem 5-c:** joint with eight 3/8"-dia bolts

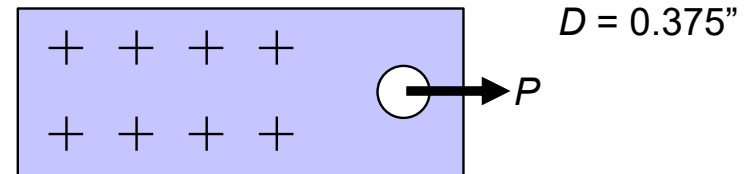

Limit load  $P = 20,000$  lb

Ultimate factor of safety  $FS_u = 1.4$

**Problem statement:** Calculate the design ultimate shear load for a bolt,  $P_{su}$

Two cases for example problem:

Case 1: The joint is shear critical

Hole dia,  $D_h = 0.386 + 0.006/-0.001$

$D_{h-max} = 0.392" = 1.045D$

$$P_{su} = 1.4(2.0)\left(\frac{20,000}{8}\right) = 7,000 \text{ lb}$$

Case 2: The joint is shear critical

Hole dia,  $D_h = 0.4062 + 0.006/-0.001$

$D_{h-max} = 0.4122" = 1.099D$

Assume only two bolts carry all the load:

$$P_{su} = 1.4\left(\frac{20,000}{2}\right) = 14,000 \text{ lb}$$

## Class Problem 5-1: Recognizing Potential Failure Modes

- A. Identify all potential ultimate failure modes of concern.
- B. Explain how you would assess those failure modes and obtain corresponding allowable loads or stresses.

- C. How would you improve the design?

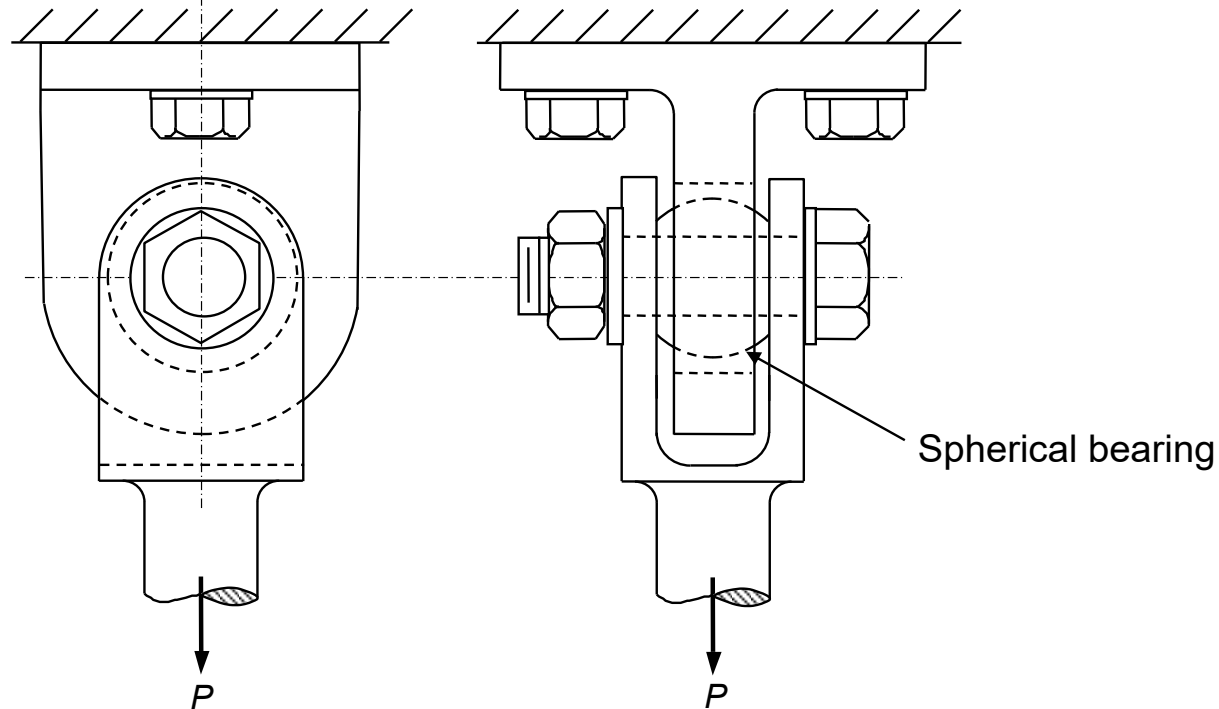

Materials: ductile metals

## Class Problem 5-2: Recognizing Potential Failure Modes

- Identify all potential ultimate failure modes of concern.
- Explain how you would assess those failure modes and obtain corresponding allowables.
- How would you improve the design?

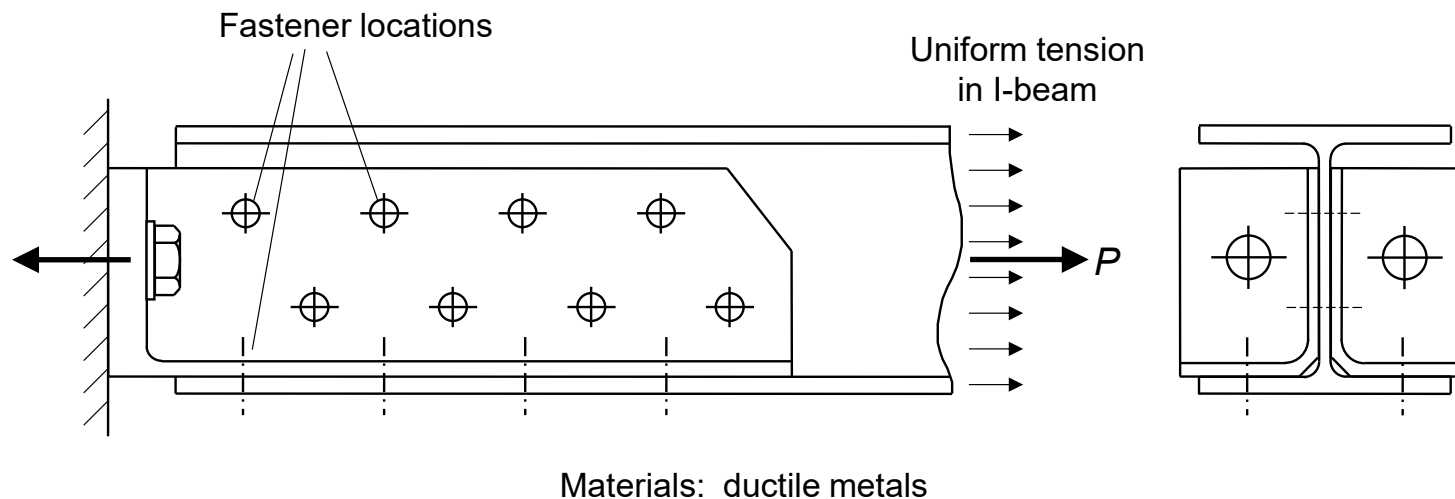

## Class Problem 5-3: Recognizing Potential Failure Modes

- A. Identify all potential ultimate failure modes of concern.
- B. Explain how you would assess those failure modes and obtain corresponding allowables.

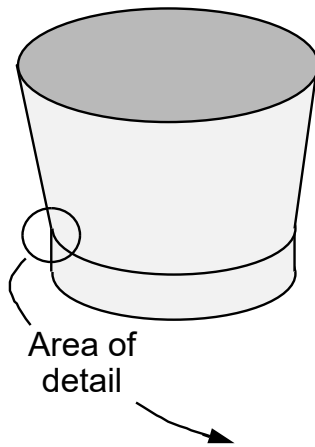

C. How would you improve the design?

Materials: ductile metals

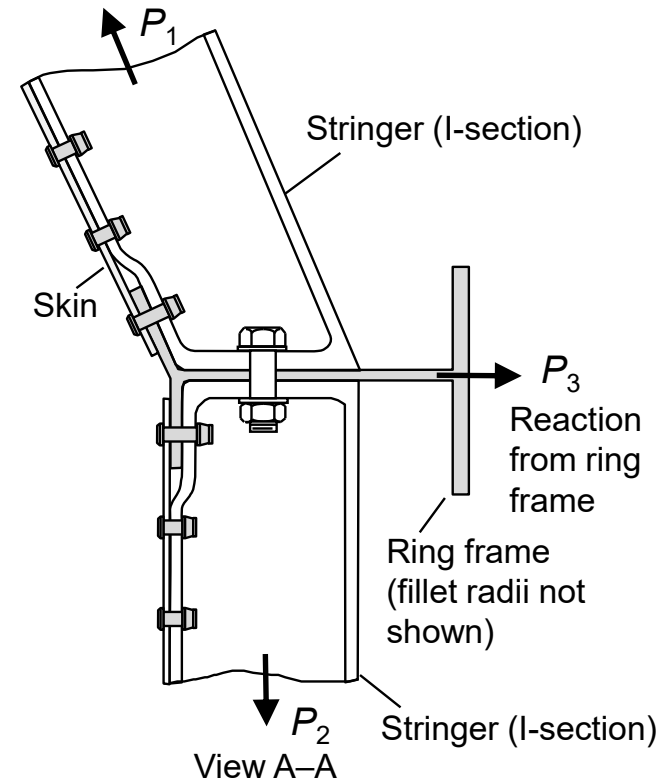
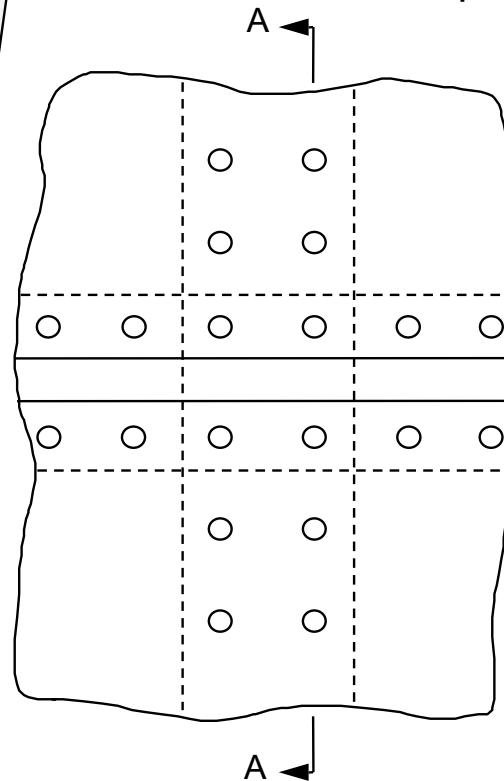

## **Bolting Composites is Similar to Bolting Metals, but with Some Key Differences**

Most composite materials are brittle, not ductile, so they are less tolerant of stress concentrations around fasteners, loads do not distribute as evenly between bolts, and joint strength varies from build to build more than for most all-metallic joints.

- More edge distance and fastener spacing required.
- A well-designed bolted joint normally develops only 20% to 50% of the full laminate tensile strength (ref. 19, Niu).

Composite laminates have low strength for interlaminar normal (through-thickness) stress.

- Use them in shear joints because you can't avoid through-thickness stress in tension joints.
- Reduce installation torque (lower clamping force).

**For a shear joint attaching composite parts, adhesive bonding typically provides greater strength than bolting when good design practices are followed and the bonding process is well developed and controlled.**

**Use bolts only if disassembly is required or if a bonded joint would see excessive peel (out-of-plane) stress.**

## Failure of a Composite Single-lap Shear Joint

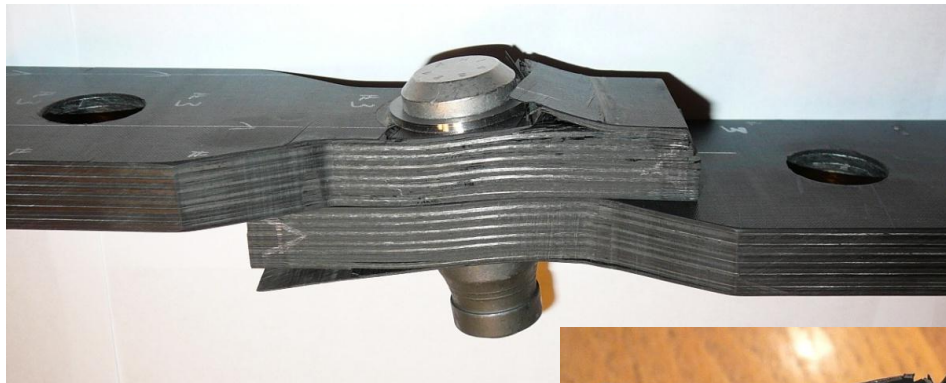

Note: The failures shown here were exacerbated by the test configuration. Aligning the applied load with plates shaped as shown in Example Problem 5-a would increase the failure load and probably be more representative of loading in the actual, large-assembly configuration.

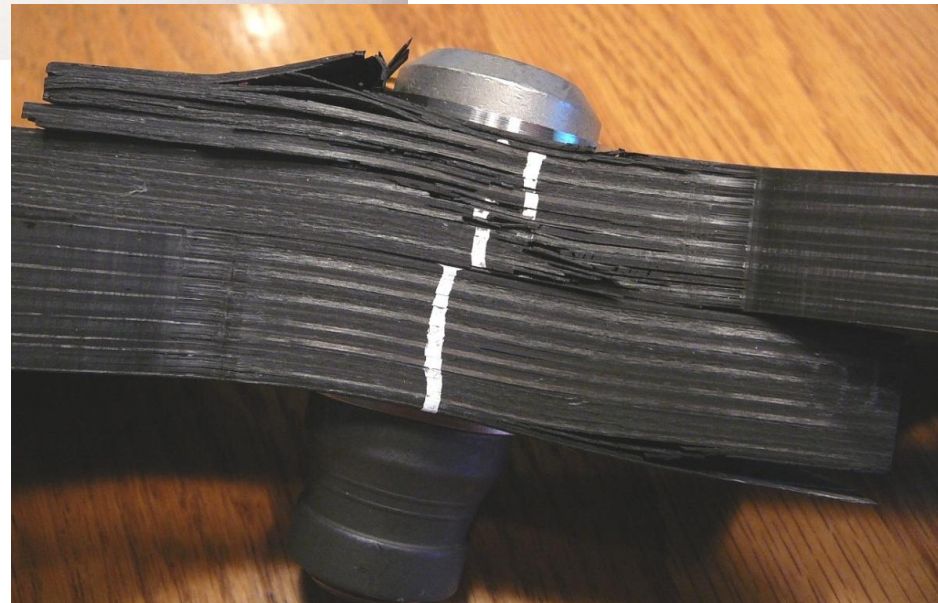

## Guidelines for a Bolted Composite Lap Joint

Recommended minimum spacing and edge distances (ref. 19):

Testing shows that adding a third row of fasteners does not increase strength much (Carl Zweben, Ph.D.)

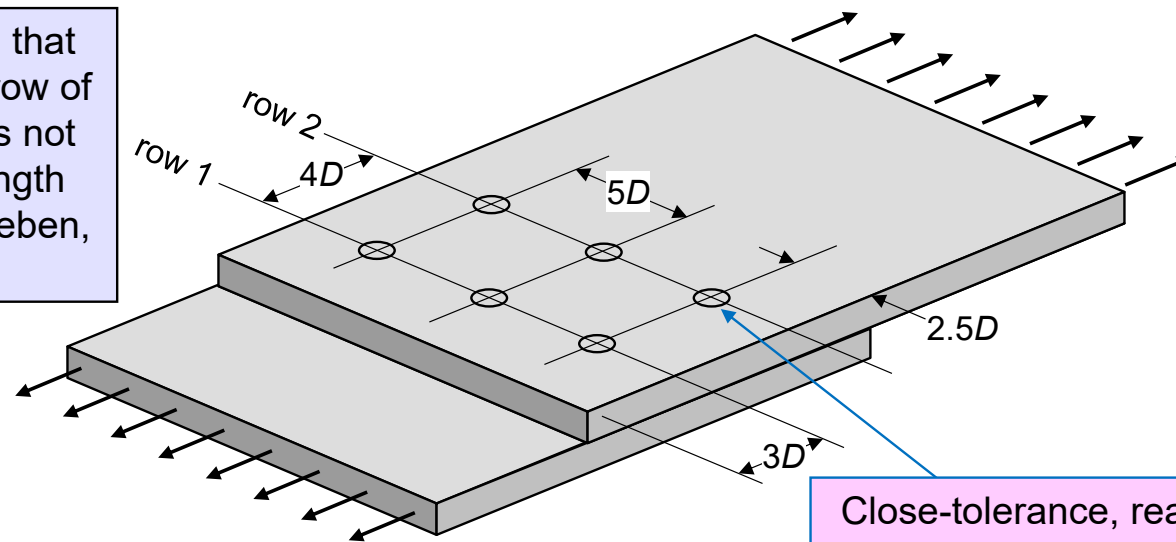

Close-tolerance, reamed holes improve joint strength, but avoid interference fits. 0.002" to 0.004" clearance recommended (Carl Zweben, Ph.D.)

Tests show that quasi-isotropic layups (e.g.,  $[0/\pm 45/90]_{\text{sym}}$ ) can usually develop the greatest joint strength (but still not more than half the laminate strength).

## **Additional Considerations for Fastening Composites**

- Adding bolts to a bonded joint can actually weaken the joint in shear because of stress concentrations around the holes.
  - If you do combine bolts and adhesive bonding, bond the joint before drilling and reaming the holes so you can get close-tolerance holes.
- Many metals, when in contact with carbon fibers, will suffer galvanic corrosion (see Sec. 7).
- Drilling can damage the laminate near the hole.
- Harder to ensure electrical conduction through joints
  - potential for arcing between fasteners in low-Earth orbit
  - copper mesh in the laminate may solve this problem
- Potential for compressive creep under bolt head
  - lost bolt preload

## Recommendations for Bolting (or Bonding) Composites

- Develop a concept for the joint.
  - With preliminary analysis based on available data and methods
- Before committing to the design, do development testing.
  - Build multiple specimens per the intended design and process, and test them to failure.
  - Derive statistically appropriate allowable loads or stresses.
- Because composites are brittle, and to help compensate for less statistical assurance for derived allowable stresses, use higher factors of safety for design than you would use for metals.
- Then proof test each flight joint.
  - And design the structure so that proof testing can be done at relatively low levels of assembly, if possible, so that budget and schedule can tolerate test failure.

**Deciding to omit proof testing without statistical justification is not sound engineering process.**

**Avoiding the need for proof testing composites is not a reasonable goal for low-volume production.**

## Key Points from Section 5

- Strength analysis for bolted joints requires an empirical basis—test data for similar joints.
  - There are no good failure theories for ductile rupture of parts of different geometry.
  - Before a bolt or a fitting made of a ductile material ruptures, local yielding at regions of concentrated stress causes load to redistribute and the state of stress to change—usually increasing strength beyond what is predicted with non-empirical methods.
- To ensure significant plastic deformation—and thus allow internal loads to redistribute—prior to ultimate failure:
  - For tension joints, ...
    - use bolts that are intended for tensile use (thick head that won't fail first),
    - if the bolts have full-diameter bodies, use bolts made of a material that has a tensile yield strength no more than about 75 – 80% of the ultimate tensile strength,
    - and use a nut, threaded insert, or tapped hole that is at least as strong as the bolt.
  - For shear joints, make the joint bearing critical.

(continued)

## Key Points from Section 5 (continued)

- Use the effective process for strength analysis, as presented in this section.
- Understand and account for the differences when designing a bolted joint with composites or other brittle materials rather than ductile materials.
- Remember: Stress analysis is not just something we do after the design is complete; it's part of the design process.
  - Take time to understand load paths and identify failure modes in the design process, before starting detail analysis.
  - Stop analyzing bad designs!

## **6. Thread Stripping and Pull-out Strength**

- How Threads Fail
- Computing Thread Shear Areas Based on Geometry
- Reducing Calculated Shear Areas by a Knockdown Factor
- Results of Pull-out Testing: #10 Fastener Installed in a Tapped Hole
- Test Results with Heli-Coils<sup>®</sup>
- Appendix: Comparison of Methods for Assessing Pull-out Strength

Permission is granted by Instar for anyone to freely copy, distribute, and print this material, but only in its unaltered form. This section may be separately copied or printed, but only in its entirety, including this page and with headers and footers intact. Unaltered individual figures and tables and portions of text may be copied or used, but only with text in quotes and with the following statement "Source: Design and Analysis of Bolted Joints (DABJ) course book, Thomas P. Sarafin, Instar Engineering and Consulting, Inc. Reproduced with permission." The date of last revision also should be included in the reference. If you have questions, contact [tom.sarafin@instarengineering.com](mailto:tom.sarafin@instarengineering.com).

## Thread Failure

From the process for strength analysis in Sec. 5:

- Start with a drawing
- Add the applied loads and reactions to the drawing
- Identify and envision potential failure modes

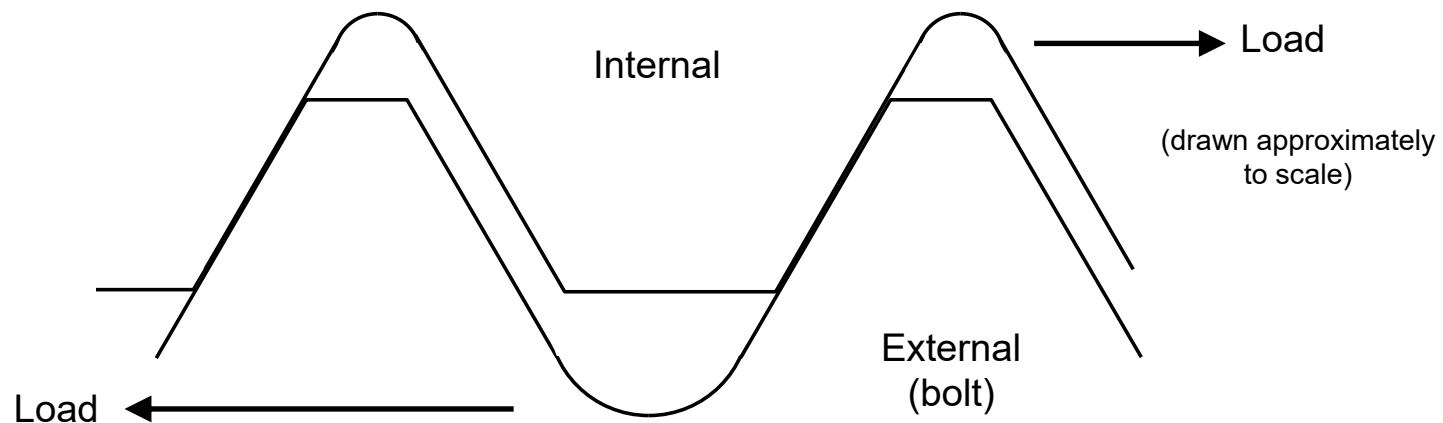

**If the threads were to fail, they would fail in shear.**

**Where would failure occur?**

## Potential Failure Surfaces for Thread Stripping

1. Internal thread fails in shear

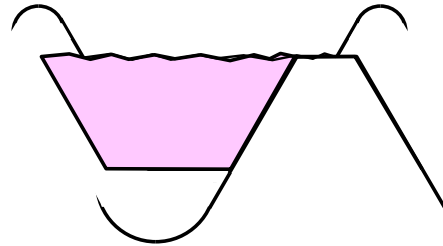

2. External thread fails in shear

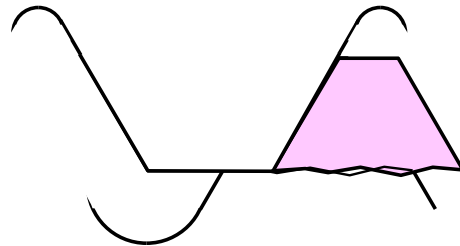

One of the above would occur before both threads fail in shear

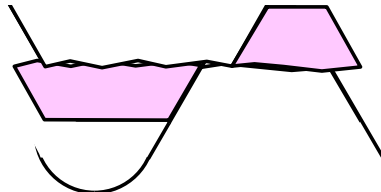

Which would fail first?

It depends on relative material strength.

But the internal thread has greater shear engagement area.

**Pull-out load** (a.k.a. **pull-out strength**): The tensile load in a bolt that causes threads to strip

## Shear Engagement Areas (a.k.a. **Shear Areas for Threads**) Based on Thread Geometry

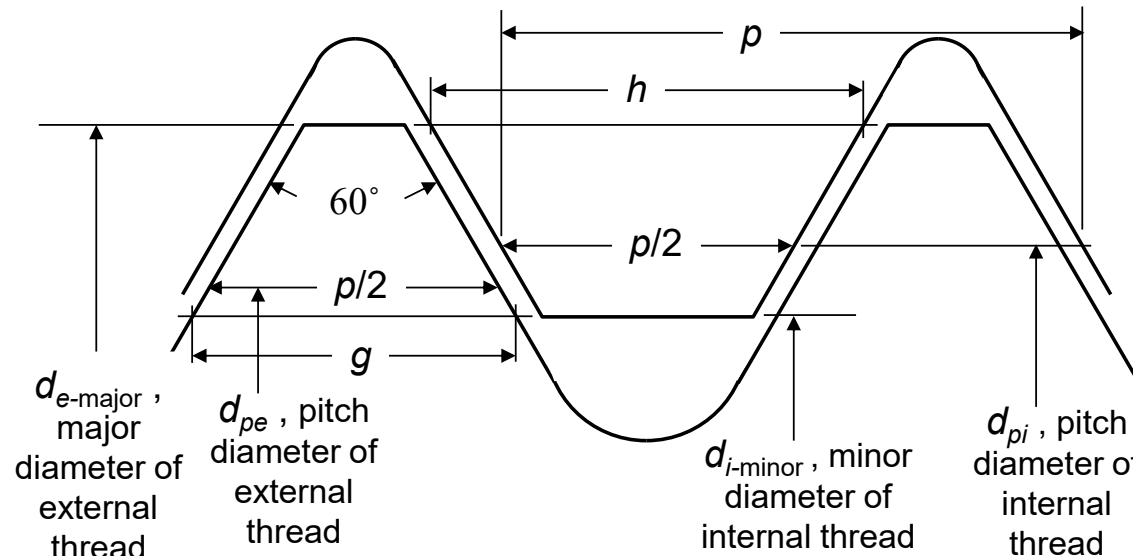

$$L_e = \text{length of engagement}$$

$$n = \text{no. threads/inch}$$

$$p = 1/n$$

$$n_t = \text{no. threads engaged} = nL_e$$

(Eq. 6.1)

From the above geometry,

$$g = \frac{p}{2} + (d_{pe} - d_{i\text{-minor}}) \tan 30^\circ \quad \text{(Eq. 6.2)}$$

so the shear area for ...

... external threads is  $A_{se} = \pi d_{i\text{-minor}} g n_t$  (Eq. 6.4)

$$h = \frac{p}{2} + (d_{e\text{-major}} - d_{pi}) \tan 30^\circ \quad \text{(Eq. 6.3)}$$

... internal threads is  $A_{si} = \pi d_{e\text{-major}} h n_t$  (Eq. 6.5)

Note: These equations appear in Appendix B of Ref. 8 (UN and UNR spec), in slightly different form along with the caution that “effective shear areas are ... somewhat less than the geometric values.” We’ll revisit this statement later in this section.

## Maximum and Minimum Shear Areas for Threads

Using extreme dimensional tolerances and Eqs. 6.1 through 6.5, the minimum and maximum shear areas, as calculated by geometry, are

$$\text{External threads} \left\{ \begin{array}{l} A_{se-\min} = \pi d_{i-\min, \max} \left[ \frac{p}{2} + (d_{pe, \min} - d_{i-\min, \max}) \tan 30^\circ \right] n_{t, \min} \quad (\text{Eq. 6.6}) \\ A_{se-\max} = \pi d_{i-\min, \min} \left[ \frac{p}{2} + (d_{pe, \max} - d_{i-\min, \min}) \tan 30^\circ \right] n_{t, \max} \quad (\text{Eq. 6.7}) \end{array} \right.$$

$$\text{Internal threads} \left\{ \begin{array}{l} A_{si-\min} = \pi d_{e-\text{major}, \min} \left[ \frac{p}{2} + (d_{e-\text{major}, \min} - d_{pi, \max}) \tan 30^\circ \right] n_{t, \min} \quad (\text{Eq. 6.8}) \\ A_{si-\max} = \pi d_{e-\text{major}, \max} \left[ \frac{p}{2} + (d_{e-\text{major}, \max} - d_{pi, \min}) \tan 30^\circ \right] n_{t, \max} \quad (\text{Eq. 6.9}) \end{array} \right.$$

**CAUTION:** It may appear that it would be conservative to use the minimum shear areas, as calculated with Eqs. 6.6 and 6.8.

But shear areas calculated directly from thread geometry such as this tend to be over-predicted (thus unsafe) for reasons given in the upcoming example.

After the example, we'll revisit these equations with use of a “knockdown” factor.

## Example Problem 6-a: Deriving an Allowable Load for Pull-out Assessment

160-ksi, A-286, #10, NAS1351 fine-thread socket head cap screw fully engaged into a tapped hole in 6061-T651 aluminum plate that is 0.250" +/- 0.010" thick:

UN & UNR Class 3 threads (ref. 8):

$$0.1840 \leq d_{e\text{-major}} \leq 0.1900$$

$$0.1674 \leq d_{pe} \leq 0.1697$$

$$0.1560 \leq d_{j\text{-minor}} \leq 0.1641$$

$$0.1697 \leq d_{pj} \leq 0.1726$$

$$n = 32 \text{ threads per inch}$$

$$p = 1/n = 0.03125"$$

$$0.240" \leq L_e \leq 0.260"$$

$$n_t = nL_e; 7.68 \leq n_t \leq 8.32$$

Use the appropriate spec for the threads you are using.

Using extreme dimensional tolerances and Eqs. 6.6 - 6.9,

$$A_{se\text{-min}} = \pi (0.1641) \left[ \frac{0.03125}{2} + (0.1674 - 0.1641) \tan 30^\circ \right] (7.68) = 0.0694 \text{ in}^2$$

$$A_{se\text{-max}} = \pi (0.1560) \left[ \frac{0.03125}{2} + (0.1697 - 0.1560) \tan 30^\circ \right] (8.32) = 0.0960 \text{ in}^2$$

$$A_{si\text{-min}} = \pi (0.1840) \left[ \frac{0.03125}{2} + (0.1840 - 0.1726) \tan 30^\circ \right] (7.68) = 0.0986 \text{ in}^2$$

$$A_{si\text{-max}} = \pi (0.1900) \left[ \frac{0.03125}{2} + (0.1900 - 0.1697) \tan 30^\circ \right] (8.32) = 0.1358 \text{ in}^2$$

(continued)

## Example Problem 6-a, continued

Allowable ultimate shear stresses for the given materials:

For external threads,  $F_{su} = 95$  ksi

For internal threads,  $F_{su} = 27$  ksi

Computed minimum pull-out strength using  $A_{se-min}$  and  $A_{si-min}$ :

For external threads,  $P_{poe,min} = 0.0694(95,000) = 6590$  lb

For internal threads,  $P_{poi,min} = 0.0986(27,000) = 2660$  lb

Considering the 27-ksi shear allowable for 6061-T651 is A-basis (99%), the actual shear strength could be as high as 35 ksi or so. Using this strength and the calculated maximum shear area of 0.1358 in<sup>2</sup>, the calculated pull-out load for internal threads is 4750 lb.

However, it would be unwise to count on a strength of 2660 lb for several reasons:

- We've neglected Poisson's effect—radial contraction of external threads.
- Threads at the material surfaces may not perfectly meet the specified dimensions, and there's typically a small chamfer at the lead-in for the tap.
- There will be small imperfections in geometry caused by the tapping process.
- The first thread takes the most load; it yields and load spreads, but how evenly?
- Thread yielding may reduce shear engagement area.

To be safe, let's reduce the calculated strength by 30% (0.70 knockdown factor) to get an allowable load:

$$P_{pou-allow} = 0.70(2660) = 1860 \text{ lb}$$

based only on my engineering judgment for a #10 screw

## Results of Example Problem 6-a Compared with Test Results

### Test information:

- NAS1351 (UNRF) socket-head cap screw, A-286
- 6061-T651 aluminum alloy plate, 1/4" thick, tapped through
- From our analysis, we've concluded the pull-out strength should be somewhere between 1860 lb and 4750 lb.

### Actual results of one test:

- **Ultimate strength was 2871 lb**
- In the range we predicted
- Data from multiple specimens would have shown scatter (especially if we used different procurement lots of fasteners and 6061-T651).

Test conducted at the U.S. Air Force Academy in March 2002

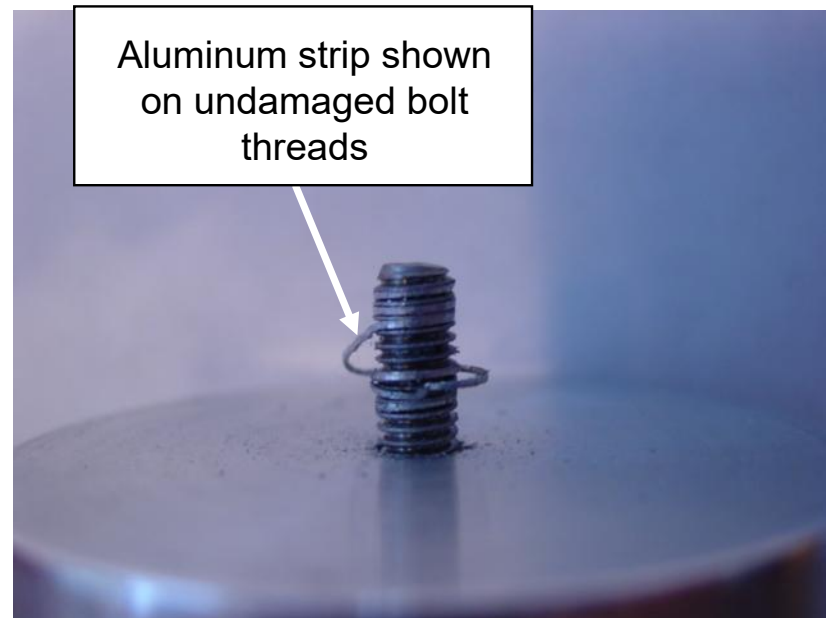

### Conclusions:

**Pull-out strength in a tapped hole is difficult to predict.**

**It's best to be safe by using uncertainty (knockdown) factors.**

## Pull-out Test Results: Load vs. Displacement

This data is from the test described on the previous page.

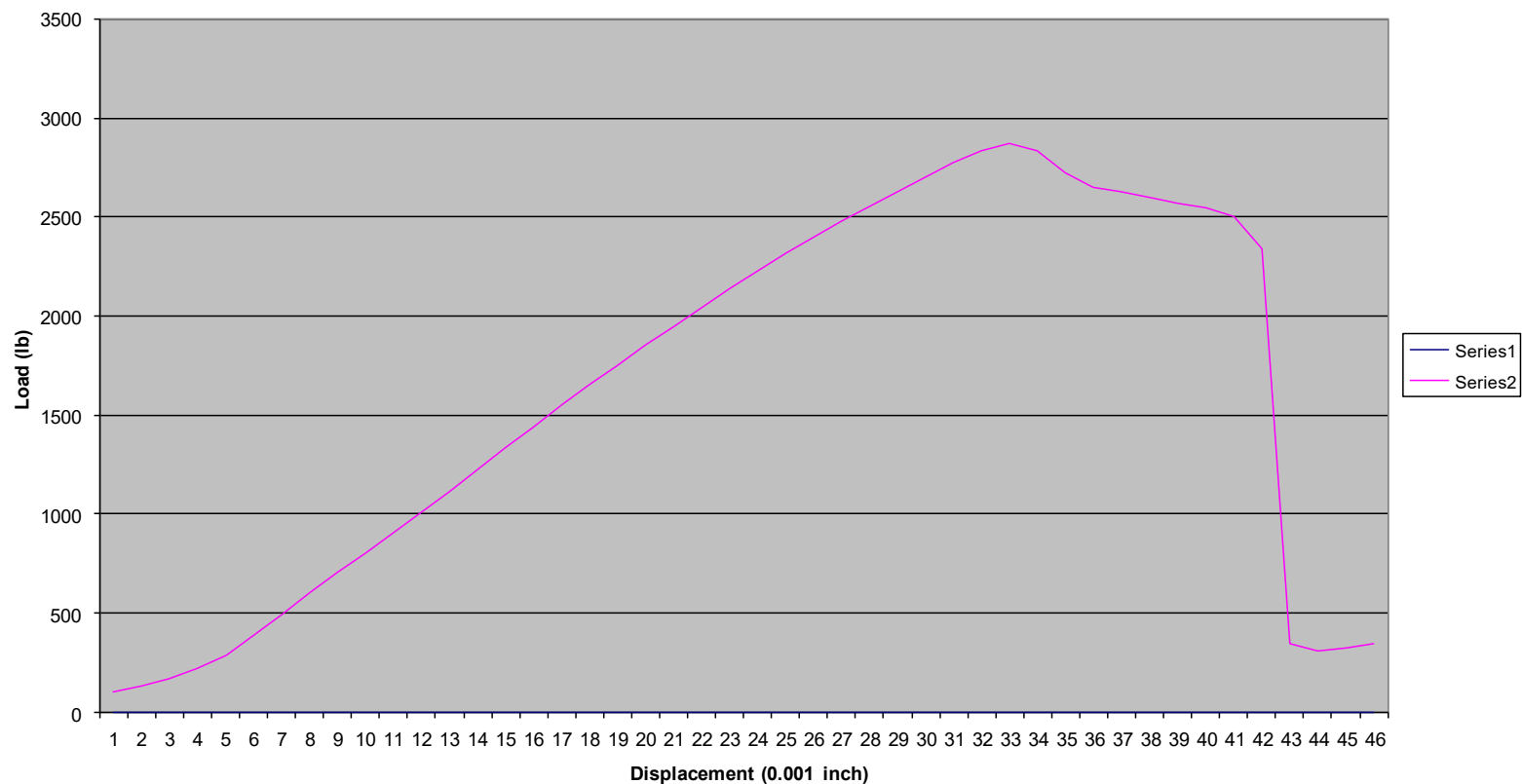

## Design Shear Areas for Pull-out Analysis

Including a knockdown factor,  $\lambda$  (lambda), in Eqs. 6.6 and 6.8 for minimum shear areas ...

Design shear area for external threads engaged in a tapped hole,

$$A_{se\text{-design}} = \lambda \pi d_{i\text{-minor,max}} \left[ \frac{p}{2} + (d_{pe,\text{min}} - d_{i\text{-minor,max}}) \tan 30^\circ \right] n_{t,\text{min}} \quad (\text{Eq. 6.10})$$

Design shear area for internal threads of a tapped hole,

$$A_{si\text{-design}} = \lambda \pi d_{e\text{-major,min}} \left[ \frac{p}{2} + (d_{e\text{-major,min}} - d_{pi,\text{max}}) \tan 30^\circ \right] n_{t,\text{min}} \quad (\text{Eq. 6.11})$$

Allowable loads for pull-out assessment (bolts in tapped holes in solid blocks of material):

External threads:

$$P_{poe\text{-allow}} = F_{su-e} A_{se\text{-design}} \quad (\text{Eq. 6.12})$$

Internal threads:

$$P_{poi\text{-allow}} = F_{su-i} A_{si\text{-design}} \quad (\text{Eq. 6.13})$$

$L_e$  = length of engagement (limited to 1.5D)  
 $n$  = no. threads/inch  
 $p = 1/n$   
 $n_{t,\text{min}}$  = minimum number of threads engaged  
 $\lambda$  = knockdown factor  
 $d_{i\text{-minor,max}}$  = maximum minor diameter of internal threads  
 $d_{pe,\text{min}}$  = minimum pitch diameter of external threads  
 $d_{e\text{-major,min}}$  = minimum major diameter of external threads  
 $d_{pi,\text{max}}$  = maximum pitch diameter of internal threads  
 $F_{su-e}$  = allowable ultimate shear stress for bolt threads  
 $F_{su-i}$  = allowable ultimate shear stress for internal tapped threads

**Table 6-1, Dimensions for UN and UNR Class 3 Threads (Ref. 8)**

Size	Nominal diameter, D	Threads per inch, n	Pitch, p	External Threads, Class 3A				Internal Threads, Class 3B				
				Max. major dia,	Min. major dia,	Max. pitch dia,	Min. pitch dia,	Max. minor dia,	Min. minor dia,	Max. pitch dia,	Min. pitch dia,	
				$d_{e-major,max}$	$d_{e-major,min}$	$d_{pe,max}$	$d_{pe,min}$	$d_{i-minor,max}$	$d_{i-minor,min}$	$d_{pi,max}$	$d_{pi,min}$	
Fine threads, UNF and UNRF	#2	0.0860	64	0.01563	0.0860	0.0822	0.0759	0.0744	0.0752	0.0691	0.0779	0.0759
	#4	0.1120	48	0.02083	0.1120	0.1075	0.0985	0.0967	0.0968	0.0894	0.1008	0.0985
	#6	0.1380	40	0.02500	0.1380	0.1329	0.1218	0.1198	0.1186	0.1110	0.1243	0.1218
	#8	0.1640	36	0.02778	0.1640	0.1585	0.1460	0.1439	0.1416	0.1340	0.1487	0.1460
	#10	0.1900	32	0.03125	0.1900	0.1840	0.1697	0.1667	0.1641	0.1560	0.1726	0.1697
	1/4	0.2500	28	0.03571	0.2500	0.2435	0.2268	0.2243	0.2190	0.2110	0.2300	0.2268
	5/16	0.3125	24	0.04167	0.3125	0.3053	0.2854	0.2827	0.2754	0.2670	0.2890	0.2854
	3/8	0.3750	24	0.04167	0.3750	0.3678	0.3479	0.3450	0.3372	0.3300	0.3516	0.3479
	7/16	0.4375	20	0.05000	0.4375	0.4294	0.4050	0.4019	0.3916	0.3830	0.4091	0.4050
	1/2	0.5000	20	0.05000	0.5000	0.4919	0.4675	0.4643	0.4537	0.4460	0.4717	0.4675
Coarse threads, UNC and UNRC	#2	0.0860	56	0.01786	0.0860	0.0819	0.0744	0.0728	0.0737	0.0667	0.0765	0.0744
	#4	0.1120	40	0.02500	0.1120	0.1069	0.0958	0.0939	0.0939	0.0849	0.0982	0.0958
	#6	0.1380	32	0.03125	0.1380	0.1320	0.1177	0.1156	0.1139	0.1040	0.1204	0.1177
	#8	0.1640	32	0.03125	0.1640	0.1580	0.1437	0.1415	0.1388	0.1300	0.1465	0.1437
	#10	0.1900	24	0.04167	0.1900	0.1828	0.1629	0.1604	0.1555	0.1450	0.1661	0.1629
	1/4	0.2500	20	0.05000	0.2500	0.2419	0.2175	0.2147	0.2067	0.1960	0.2211	0.2175
	5/16	0.3125	18	0.05556	0.3125	0.3038	0.2764	0.2734	0.2630	0.2520	0.2803	0.2764
	3/8	0.3750	16	0.06250	0.3750	0.3656	0.3344	0.3311	0.3182	0.3070	0.3387	0.3344
	7/16	0.4375	14	0.07143	0.4375	0.4272	0.3911	0.3876	0.3717	0.3600	0.3957	0.3911
1/2	0.5000	13	0.07692	0.5000	0.4891	0.4500	0.4463	0.4284	0.4170	0.4548	0.4500	

**Table 6-2, Shear Areas for UN and UNR Class 3 Threads, with Length of Engagement = 1D**

Size	Nominal diameter, D	Minimum Shear Area Based on Geometry Alone		Suggested Knock-down Factor, $\lambda$	Suggested Design Shear Areas (Eqs. 6.10 and 6.11)		
		External threads	Internal threads		External threads, $A_{se\text{-design}}$	Internal threads, $A_{si\text{-design}}$	
Fine threads, UNF and UNRF	#2	0.0860	0.00956	0.01463	0.50	0.00478	0.00732
	#4	0.1120	0.01694	0.02594	0.50	0.00847	0.01297
	#6	0.1380	0.02713	0.04025	0.55	0.0149	0.0221
	#8	0.1640	0.03997	0.05747	0.65	0.0260	0.0374
	#10	0.1900	0.05359	0.07805	0.70	0.0375	0.0546
	1/4	0.2500	0.10074	0.13736	0.75	0.0756	0.1030
	5/16	0.3125	0.16254	0.21756	0.75	0.122	0.163
	3/8	0.3750	0.24156	0.31392	0.80	0.193	0.251
	7/16	0.4375	0.33313	0.43344	0.80	0.267	0.347
	1/2	0.5000	0.44356	0.56656	0.80	0.355	0.453
Coarse threads, UNC and UNRC	#2	0.086	0.00938	0.01493	0.50	0.00469	0.00746
	#4	0.112	0.01652	0.02636	0.50	0.00826	0.01318
	#6	0.138	0.02624	0.04088	0.55	0.0144	0.0225
	#8	0.164	0.03932	0.05800	0.65	0.0256	0.0377
	#10	0.190	0.05271	0.07981	0.70	0.0369	0.0559
	1/4	0.250	0.09617	0.14062	0.75	0.0721	0.1055
	5/16	0.313	0.15701	0.22197	0.75	0.118	0.166
	3/8	0.375	0.23211	0.32238	0.80	0.186	0.258
	7/16	0.438	0.32110	0.44308	0.80	0.257	0.354
	1/2	0.500	0.42687	0.58192	0.80	0.341	0.466

You can scale the areas in this table for actual minimum length of thread engagement, but to be safe I would go only up to 1.5D.

Suggested knockdown factors are based solely on judgment. Use an ultimate factor of safety and a fitting factor. Critical joints should be verified by test.

See the appendix to this section for a comparison with other methods of thread-stripping analysis.

## **An Important Caution Regarding Thread-Stripping Analysis**

**The presented method of assessing thread stripping is meant only for bolts in tapped holes in “solid blocks” ( $e/D$  edge distance ratio of at least 1.5) made of ductile materials.**

**This method is not for parts made of brittle materials and not for bolts used with nuts or threaded inserts, which expand under load, thus reducing the shear engagement area.**

## Thread Engagement and Thread Stripping per NASA-STD-5020B

### Sec. 4.7.4:

*To avoid thread stripping as the critical failure mode, thread engagement in an internally threaded part other than a nut, nut plate, or insert should be selected to ensure the minimum number of engaged complete threads such that the fastener would fail in tension before threads would strip. It is desirable to have the fastener fail in tension before the threads strip to facilitate ease of repair and to increase the likelihood that any failed hardware may be detected. In addition, fastener tensile failures typically exhibit more plastic deformation prior to rupture, allowing loads to redistribute between fasteners before failure occurs in any one threaded fastening system.*

## Back to Example Problem 6-a: Now Let's Use a Heli-Coil® Insert

- Same screw (#10-32, 160 ksi) and same plate material (6061-T6) and thickness ( $\frac{1}{4}$ "
- Stainless steel Heli-Coil
- In most cases, an insert adds strength because the tapped hole in the aluminum is of larger diameter, making a larger shear engagement area in the weak material.
- An insert doesn't always increase strength, though. In our example,
  - The internal threads in the aluminum are indeed at a larger diameter: The maximum pitch diameter of the internal thread is now 0.2123", as compared with 0.1726" for the case with no insert (23% greater diameter and shear area per thread).
  - But Heli-Coils are sold in  $\frac{1}{2}$ - $D$  length increments, and the  $\frac{1}{4}$ " thickness leaves room only for a 1- $D$  insert (length of insert,  $L_i$  = bolt diameter; in this case,  $L_i$  = 0.190").
    - Thus, there are now only  $0.190 \times 32 = 6.08$  threads engaged, as compared with 7.68 threads (minimum) for the case with no insert and 0.240" thickness (21% fewer threads engaged).
  - The theoretical shear engagement area for the internal thread is about the same, with or without the insert.

**What do you think: Will the insert increase the pull-out strength?**

## Test Results: #10-32 Fasteners in Heli-Coil® Inserts

- NAS1351 (UNRF) socket head cap screw, A286 (160 ksi ult tensile strength)
- 6061-T651 aluminum alloy plate, ¼” thick
- 1-D stainless-steel, helical-coil insert

12 specimens tested:

- **Average pull-out strength = 2481 lb**  
(as compared with 2871 lb for one test with no insert)
- Range: 2318 lb to 2635 lb

**However, the failure mode was not stripping of the internal threads.**

**The threads on the screw stripped!**

**Same for all 12 specimens.**

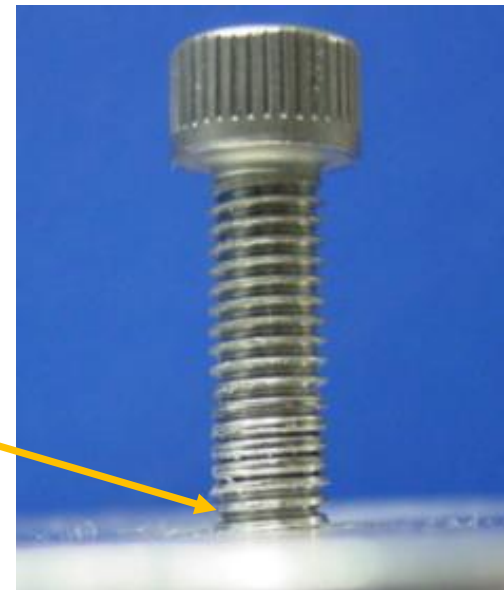

Test conducted at the U.S. Air Force Academy in March 2002

## What caused the screw threads to strip at such a low load?

A plausible theory: The insert wire expanded into the soft aluminum and rotated.

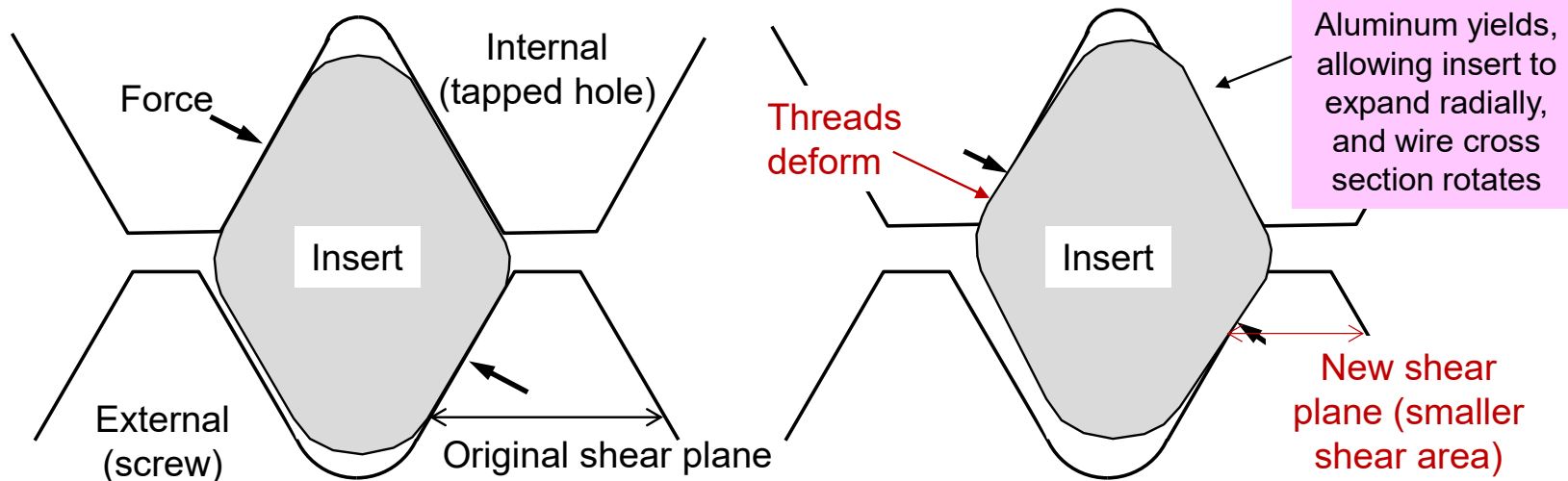

**Linear theory is sometimes unconservative!**

**Recommendation: Don't try to calculate thread stripping when using Heli-Coils! Adhere to the insert's procurement specification (NASM8846 for helical-coil inserts, Table V), which provides guidance for insert length needed to provide full fastener strength depending on shear strength of parent material. If using a shorter length, reduce the allowable load.**

For 6061-T651 aluminum alloy, fully developing the fastener strength requires a 2-D insert!

## Pull-out Test Results: Load vs. Displacement, With Insert

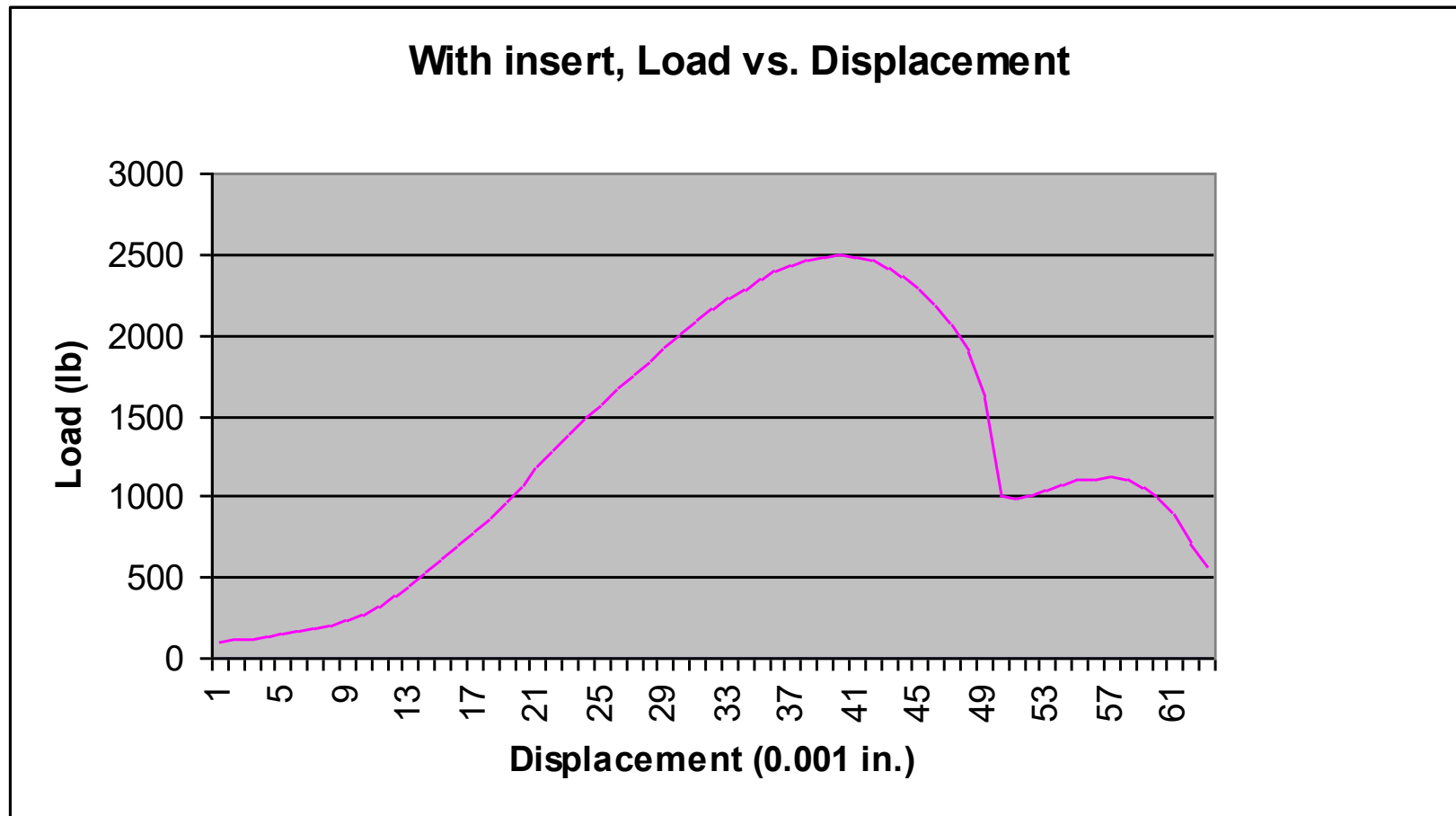

Test conducted at the U.S. Air Force Academy in March 2002

## More Results of Insert Pull-out Test

Of the 12 specimens tested (the test described on the preceding pages, #10-32 cap screws),

- 4 fasteners were not preloaded
- 4 were torqued to 60 in-lb
- 4 were torqued to 100 in-lb, which yielded the fasteners

Which do you think carried the highest applied tensile load?

Test results:

<u>Install. torque</u>	<u>Average strength</u>	<u>Unbiased sample standard deviation</u>
None	2428 lb	81 lb
60 in-lb	2454 lb	121 lb
100 in-lb	2561 lb	50 lb

- Conclusions:**
1. Sample size is too small to draw clear conclusions, but the trend was that strength increased with higher preload.
  2. The reason for this trend is unknown (strengthening of aluminum from rotation of Heli-Coil under pressure, allowing less expansion of Heli-Coil?).
  3. The objective was to see if preload interacts with applied load to reduce strength, and this clearly was not the case.

## Appendix to Section 6

# Comparison of Methods Used To Assess Thread Stripping (Pull-out Strength)

Two other methods of thread-stripping (pull-out) analysis appear in Ref. 20 (Barrett) and Ref. 23 (Bruhn supplement).

These methods are presented in the following pages, along with my comments and a comparison of methods.

## Method in Ref. 20 (Barrett)

From Ref. 20 p. 21, the allowable load for pull-out assessment is

$$P_{po-allow} = \frac{\pi d_m F_{su} L_e}{3} \quad (\text{Eq. 6.14})$$

where  $d_m$  = mean diameter of threaded hole  
 $\approx d_{pi}$ , the pitch diameter for  
internal threads  
 $F_{su}$  = allowable ultimate shear stress  
for the weaker material  
 $L_e$  = length of engagement

which makes the design shear area for both  
external and internal threads ...

$$A_{se-design} = A_{si-design} = \frac{\pi d_{pi} L_e}{3} \quad (\text{Eq. 6.15})$$

My comments on this method are on the next page ...

## Method in Ref. 20 (Barrett)—Comments

My comments on the Ref. 20 method and the applicable text in the reference:

- The same equation is used to calculate pull-out strength for internal and external threads, even though internal threads have greater shear area.
- The equation doesn't account for thread form and class.
- Text says “The 1/3 factor is empirical,” but no reference to test data or report given.
- The text also says “If the threads were perfectly mated, this factor (1/3) would be 1/2 ...”, which is not true. “The 1/3 is used to allow for mismatch between threads.” An inaccurate statement
- No stated limit on  $L_e$ .
- Bottom line: This method has the benefit of being quite simple and is probably conservative for  $L_e \leq 1.5D$  or  $2.0D$ , sometimes excessively so.

## The Method in Bruhn Supplement

From Ref. 23 (Bruhn supplement) p. 76, the “load at which threads strip from nut,” which I’ll assume is meant to be the allowable load for assessing pullout for internal threads, is

$$P_{poi-allow} = 0.4\pi d_{e-major} L_e F_{su-i} \quad (\text{Eq. 6.16})$$

and the “load at which threads strip from bolt” is

$$P_{poe-allow} = 0.4\pi d_{i-minor} L_e F_{su-e} \quad (\text{Eq. 6.17})$$

which makes the design shear areas for external and internal threads ...

$$A_{se-design} = 0.4\pi d_{i-minor} L_e \quad (\text{Eq. 6.18})$$

$$A_{si-design} = 0.4\pi d_{e-major} L_e \quad (\text{Eq. 6.19})$$

where

$L_e$  = length of engagement

$d_{e-major}$  = major diameter of external threads

$d_{i-minor}$  = minor diameter of internal threads

$F_{su-e}$  = allowable ultimate shear stress for bolt threads

$F_{su-i}$  = allowable ultimate shear stress for internal tapped threads

My comments on this method are on the next page ...

## The Method in Bruhn Supplement—Comments

My comments on this method and the applicable section of the reference:

- The 0.4 factor is for “efficiency of nut (or bolt) threads.” No reference or test substantiation given.
- The text says the equations apply “for bolt-nut combinations and tapped hole combinations.” No acknowledgement that nuts expand under load, thus pulling threads away from the bolt’s threads. Do not use these equations when bolts are paired with nuts or threaded inserts, only for bolts in holes tapped in solid blocks of material.
- The text says “If the bolt material has a higher strength than the nut material the threads will be stripped from the nut.” This is true only if the bolt’s material strength is significantly higher than that of the nut material; internal threads have greater shear area.
- The equations don’t account for thread class.
- Doesn’t say whether to use maximum, minimum, or nominal thread dimensions. Use of max minor diameter of internal thread gives higher strength for external threads, per Eq. 6.18, but actually reduces strength for external threads.
- No stated limit on  $L_e$ .
- Bottom line: This method also is quite simple and is probably conservative for  $L_e \leq 1.5D$  or  $2.0D$ .

**Table 6-3, Comparison of Methods for Pull-out Assessment  
UN and UNR Class 3 Threads, with Length of Engagement = 1D\***

Size	Nominal diameter, $D$	Knockdown factor, $\lambda$ , used in Eqs. 6.10 & 6.11	Design Shear Areas for External Threads, $A_{s\text{-design}}$			Design Shear Areas for Internal Threads, $A_{s\text{-design}}$			
			Eq. 6.10 with knockdown factors suggested herein	Ref. 20 (Barrett), Eq. 6.15	Ref. 23 (Bruhn Suppl.), Eq. 6.18	Eq. 6.11 with knockdown factors suggested herein	Ref. 20 (Barrett), Eq. 6.15	Ref. 23 (Bruhn Suppl.), Eq. 6.19	
			*Scale the suggested areas for actual minimum length of thread engagement, up to 1.5D (see next page).						
Notes:									
<ul style="list-style-type: none"> <li>• For the Ref. 20 method, I used the average of max/min pitch diameter for internal threads.</li> <li>• For the Ref. 23 method, I used the average of max/min thread dimensions.</li> </ul>									
UNF & UNRF Class 3	#2	0.0860	0.50	0.00478	0.00693	0.00780	0.00732	0.00693	0.00909
	#4	0.1120	0.50	0.00847	0.01169	0.01310	0.01297	0.01169	0.01545
	#6	0.1380	0.55	0.0149	0.0178	0.0199	0.0221	0.0178	0.0235
	#8	0.1640	0.65	0.0260	0.0253	0.0284	0.0374	0.0253	0.0332
	#10	0.1900	0.70	0.0375	0.0341	0.0382	0.0546	0.0341	0.0446
	1/4	0.2500	0.75	0.0756	0.0598	0.0675	0.1030	0.0598	0.0775
	5/16	0.3125	0.75	0.122	0.094	0.106	0.163	0.094	0.121
	3/8	0.3750	0.80	0.193	0.137	0.157	0.251	0.137	0.175
	7/16	0.4375	0.80	0.267	0.186	0.213	0.347	0.186	0.238
	1/2	0.5000	0.80	0.355	0.246	0.283	0.453	0.246	0.312
UNC & UNRC Class 3	#2	0.086	0.50	0.00469	0.00679	0.00759	0.00746	0.00679	0.00907
	#4	0.112	0.50	0.00826	0.01138	0.01258	0.01318	0.01138	0.01540
	#6	0.138	0.55	0.0144	0.0172	0.0189	0.0225	0.0172	0.0234
	#8	0.164	0.65	0.0256	0.0249	0.0277	0.0377	0.0249	0.0332
	#10	0.190	0.70	0.0369	0.0327	0.0359	0.0559	0.0327	0.0445
	1/4	0.250	0.75	0.0721	0.0574	0.0633	0.1055	0.0574	0.0773
	5/16	0.313	0.75	0.118	0.091	0.101	0.166	0.091	0.121
	3/8	0.375	0.80	0.186	0.132	0.147	0.258	0.132	0.174
	7/16	0.438	0.80	0.257	0.180	0.201	0.354	0.180	0.238
	1/2	0.500	0.80	0.341	0.237	0.266	0.466	0.237	0.311

## Conclusions

- The Ref. 20 and 23 methods are simple and, in most cases, more conservative than the method suggested herein.
  - Exception: small screws (for which I prefer to be more conservative because small imperfections and thread damage can lead to bigger strength reduction)
- Regardless of the method used, in absence of sufficient test data to account for variation, I recommend using no more than 1.5D length of engagement in the analysis.
  - Based on uncertainty of whether the plastic deformation associated with thread yielding would ensure the bottom thread is carrying its share of load.
- Use these methods only for bolts going into tapped holes in solid blocks of material. When using nuts or threaded inserts, use their specified minimum strengths.

Which of the three presented methods is best?

Unknown because of inadequate test data.

Use the method that makes you feel confident—rather than using the method that shows a positive margin of safety!

Remember, the engineer doing the analysis assumes responsibility for structural integrity.

Account for uncertainty with an ultimate factor of safety and a fitting factor.

## **7. Selecting Hardware and Detailing the Design**

- Selecting Compatible Materials
- Selecting the Nut: Ensuring Strength Compatibility
- Threaded Inserts and Nut Plates
- Use of Washers
- Bolt Features and Geometry
- Selecting Fastener Length and Grip
- Guidelines for Simplifying Assembly
- Establishing Preload
- Torque-Preload Relationship
- Locking Features and Associated NASA-STD-5020B Requirements
- Maintaining Preload with Prevailing-Torque Locking Features
- Appendix 7A.1: Miscellaneous Design Data and Information
- Appendix 7A.2: Additional Torque-Preload Test Data

Permission is granted by Instar for anyone to freely copy, distribute, and print this material, but only in its unaltered form. This section may be separately copied or printed, but only in its entirety, including this page and with headers and footers intact. Unaltered individual figures and tables and portions of text may be copied or used, but only with text in quotes and with the following statement "Source: Design and Analysis of Bolted Joints (DABJ) course book, Thomas P. Sarafin, Instar Engineering and Consulting, Inc. Reproduced with permission." The date of last revision also should be included in the reference. If you have questions, contact [tom.sarafin@instarengineering.com](mailto:tom.sarafin@instarengineering.com).

Table 7-1:

## Materials and Combinations to Avoid for Space Applications

Material	Why it is not suitable
Cadmium, zinc, and tin platings	These materials grow <b>whiskers</b> (hair-like metallic crystals) in a vacuum, especially tin, leading to short circuits and contamination. Cadmium and zinc outgas excessively. Cadmium is toxic.
Silver (when exposed to atomic oxygen)	Excessive oxidation and migration
Silver in contact with titanium when above 450° F	Silver can migrate into grain boundaries of titanium and reduce ductility
Nylon	Outgasses and has temperature limits
Anaerobic adhesives and thread fillers (if not cured properly)	Migrates uncontrollably, then hardens in a vacuum
Carbon steel or low-alloy steel	Becomes brittle and subject to fracture when cold
Metals of similar hardness for both threaded parts without lubricant or a separating coating	<b>Galling</b> (seizing from adhesion of sliding materials under pressure—a common problem with fasteners)

Per NASA-STD-5020B:

- 4.7.1: Materials used in threaded fastening systems shall comply with NASA-STD-6016.
- 4.8.1b: The engineering documentation shall specify required lubricants, coatings, or sealants used in threaded fastening systems, the area to which they are applied, as well as their application processes.

## **A-286: The Most Commonly Used Fastener Material in the Space Industry**

### Advantages:

- High strength
- Good ductility; elongation typically 12% or more
- When treated to 160 ksi (1100 MPa) minimum ultimate tensile strength, minimum yield strength is only 120 ksi (827 MPa).
  - When combined with the material's elongation, this spread between ultimate and yield strengths ensures significant plastic deformation prior to tensile rupture of bolts, even those with full-diameter bodies. (This advantage is lost to some extent when treated to 180 ksi or higher.)
- Nonmagnetic
- Resistant to corrosion and hydrogen embrittlement
- Heat resistant
  - Good up to about 1200° F (650° C)
  - Good toughness at cryogenic temperatures
- Many different aerospace-grade A-286 fasteners available

### Disadvantage:

- Galls easily when mated with materials of similar hardness (use a coating or a lubricant)

**Table 7-2:  
Some Suitable Fastening-System Materials for Space Use**

Bolt	Nut or Insert	Comments
A-286 treated to 160 or 180 ksi	A-286	To prevent galling, use silver-plated nuts, a lubricant, or an insert made of a low-strength material such as 300-series stainless. (Note: Silver plating may not be acceptable at low-Earth orbit.)
Titanium 6Al-4V treated to 160 ksi	A-286 or titanium	Galls even more easily than A-286, so use a lubricant. Better for shear loading than for tension because tensile failure can occur with little plastic deformation* (discussed in Sec. 5 herein). Creeps at high temperature, and low toughness at cryogenic temperatures.
300-series stainless	A-286	Low strength (80 ksi ultimate, 30 ksi yield), so use in lightly loaded applications only.
Inconel 718	Inconel 718	Up to 220 ksi tensile strength. Corrosion resistant and good for a wide range of temperatures. Lubricate to avoid galling. Can fail in tension with little plastic deformation*, same as titanium. Expensive.
MP35N	MP35N or Inconel 718	Up to 300 ksi tensile strength. Corrosion resistant. Lubricate to avoid galling. Can fail in tension with little plastic deformation*, same as titanium. Very expensive.
*if the bolt has a full-diameter body		

Some acceptable lubricants: Molybdenum-disulphide dry film and Braycote 601EF and 602EF grease

**Bolts with full-diameter bodies that are  $\geq 200$  ksi (or 160 ksi titanium) should be reserved for shear joints because they can fail in tension with little apparent ductility.**

## Fastener and Fitting Materials for Attaching Carbon-Fiber Composites

Materials to avoid in contact with carbon fibers:

- Aluminum and magnesium alloys
  - galvanic corrosion
- Low-alloy (e.g., 4130 and 4340) steels and martensitic (e.g., 410 and 420) stainless steels
  - galvanic corrosion
- Cadmium and Zinc coatings
  - rapid deterioration of coating

Acceptable materials:

- A-286
- Titanium
- MP-35N
- Inconel 718
- 304 and 316 stainless steels

Sources: refs. 19 and 22

## Selecting the Nut

The nut should be able to develop the full tensile strength of the bolt. Minimum strength in the nut specification should be at least as high as the bolt's minimum strength.

- Ensures threads will not strip before the bolt breaks through its cross section.
- Thread stripping has less apparent ductility and is hard to detect if it begins when torquing at assembly.

But the ideal nut is made of a ductile material that is weaker than the bolt material.

- Ideally, the internal threads will yield and spread loads more uniformly in the bolt threads, thus reducing stress concentrations and improving fatigue life.

A nut made of a weaker material than the bolt material can still be matched strength-wise with the bolt. The ultimate tensile strength of the nut material doesn't by itself matter. It's a combination of material strength and geometry that ensures threads won't strip before the bolt breaks.

**Match the hardware.**

**For a 160-ksi bolt, use a 160-ksi nut.**

**A “160-ksi nut” is not necessarily made of 160-ksi material; it's designed to develop the strength of a 160-ksi bolt.**

**Even if the bolt is for shear only, when used in a clearance hole it's best to match hardware strength to enable higher preload.**

**Unfortunately, some bolts have small thread lengths and require relatively thin nuts that can't develop the bolt's tensile strength.**

## Examples of Mismatched Hardware

Some combinations in use on space programs (NASA survey results, Dec 2007):

Dia.	Fastener spec	Fastener material	Material min. ultimate tensile strength (ksi)	Specified min. tensile strength for bolt (lb)	Nut or insert	Nut or insert spec	Nut or insert material	Specified min. tensile strength for nut or insert (lb)
#10	NAS1351	A286	160	<b>3200</b>	Keensert	MS51830	Steel	<b>2500</b>
#10	NAS1351	A286	160	<b>3200</b>	Nut	MS21043	A286	<b>2460</b>
#10	NAS6703	A286	160	<b>3620</b>	Nut	NAS1291	A286	<b>2460</b>
#10	NAS6703	A286	160	<b>3620</b>	Nut	NAS1805	A286	<b>4070</b>
3/8	ST12007	MP35N	260	<b>22800</b>	Keensert	MS51831	A286	<b>14050</b>
3/8	NAS1953	A286	180	<b>17100</b>	Nut	NAS1805	A286	<b>17100</b>
3/8	NAS6705U	A286	160	<b>15200</b>	Nut	MS21043	A286	<b>11450</b>

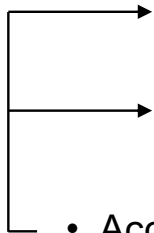

- Acceptable combinations for strength
  - But some sizes are dimensionally incompatible—discussion forthcoming.
- For all other combinations listed above, the nut or insert is the weak link. Threads may strip at a load that is lower than the specified bolt strength, and the analyst may not think to check the nut or insert.

**Match your hardware strength-wise!**  
**In analysis, consider the entire fastening system!**

## Threaded Inserts: Keenserts® and Heli-Coils®

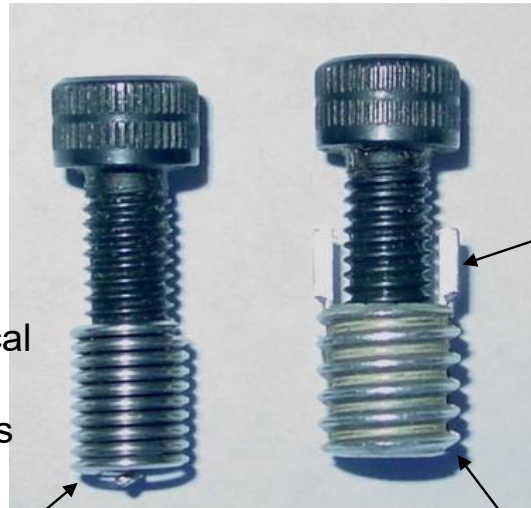

Heli-Coil: helical wire with a diamond cross section

Has a diameter slightly larger than the tapped hole; compressed as it's installed, "locking" in place

Keensert: a threaded bushing

Keys used to lock insert in place

**Check the insert's load rating (specified minimum strength) and pull-out strength. Pick an insert that can fully develop the strength of the bolt.**

Keenserts and Heli-Coils can be purchased as free-running or locking



Heli-Coil

Tang used for installation then broken off

## Heli-Coils® or Keenserts®? How do we choose?

### Why use Heli-Coils?

- Smaller outer diameter, thus requires less edge distance
- Allows smaller true-position tolerance, enabling smaller-diameter holes in the mating part
- Easier to replace a locking Heli-Coil if the locking feature becomes ineffective; Keenserts must be drilled out
- Keys used to stake Keenserts can cause cracks in parent material if the installation process isn't followed properly
- Lighter in weight

### Why use Keenserts?

- Heli-Coils require special tools for tapping and installation
- Higher strength possible for given thickness of parent material
- Strength of a Heli-Coil is more dependent on thread engagement
- Breaking off Heli-Coil tangs creates loose pieces that must be accounted for (Note: tangless Heli-Coils are available)
- Heli-Coils can be pushed in during installation and can back out with fastener removal

**My own preference: Keenserts. They're more robust (fewer problems), in my opinion. But it depends on the situation. Both work.**

**Suggestion: Use free-running Keenserts, with the locking feature (a) in the screw (e.g., polymer patch) or (b) provided with an adhesive liquid thread filler (discussed later in this section).**

## Nut Plates (aka Plate Nuts)

Used for sheets and plates that are too thin for a tapped hole or a threaded insert. Used mainly for shear joints.

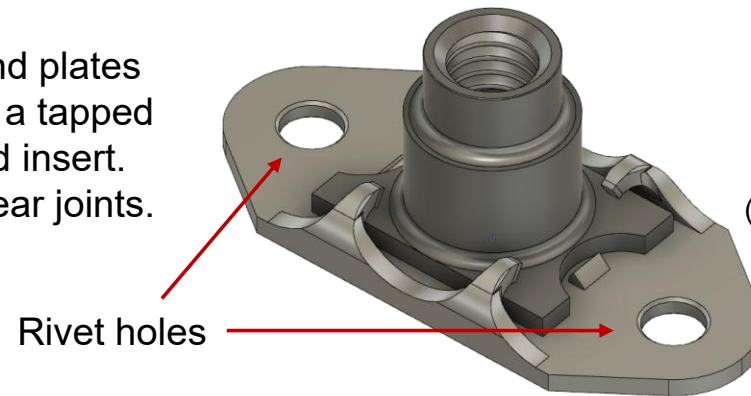

NA2466 floating nut plate  
(image from <https://nafcoua.com/products/na2466-self-locking-two-lug-plate-nut/>)

### Advantages

Once the nut plates are installed, fastener installation is simplified because fewer parts are handled and no access to the nut plate side is needed.

Can keep fastener threads out of the shear plane and out of bearing.

Floating nut plates, with minimum radial float of 0.020" to 0.030", allow holes in mating parts to be tighter than when using threaded inserts.

Locking nut plates are available.

### Disadvantages

Installing nut plates is time consuming and expensive.

Tensile strength is typically that of a 125 ksi fastener\*, so you can't preload as high as when using 160 ksi bolts and 160 ksi nuts or inserts.

Rivet holes introduce additional locations of stress concentration and potential fatigue failure.

Locking feature can wear out with multiple installations.

\*The nut plate shown above is advertised as “160 ksi Ft<sub>u</sub>”, but the minimum tensile strength is the same as for a 125 ksi bolt.

## Use of Washers

Using washers under the bolt head and under the nut usually leads to a better joint:

- Provides a smooth, hard, low-friction surface for contact with the rotating nut or bolt head during torquing
  - prevents damaging the joint members
  - leads to higher, more predictable preload
- Spreads load over greater contact area
  - reduces contact stress on fitting material, which can allow greater preload
  - leads to increased stiffness of clamped fittings, hence less cyclic load for the bolt in a tension joint (addressed in Sec. 8)
- Can span slotted holes or clearance holes
- Accommodates dimensional tolerances
  - can stack washers if needed to ensure proper grip length (up to 3 is commonly permitted)

On the other hand, for small fasteners that will be installed at the vehicle level of assembly and that don't require a high preload, consider omitting washers.

- A washer is another part that can be dropped into the flight assembly.
- When dropped, it must be found!

## Washer Considerations

For the highest preload with high-strength bolts, washers should be made of a high-strength alloy.

- Preferably with lubricant between the nut (or bolt head) and the washer to ensure no galling.
- Washers made of a low-strength alloy such as 300-series stainless may yield or creep under the bolt head, causing some loss of preload.
- Still, 300-series washers are commonly used with A286 bolts.



NAS1149C0363R (300-series CRES) washer that yielded under a preloaded A-286 socket-head cap screw

Washers shouldn't be too thin.

- A 0.032"-thick washer with high-strength bolts of size #10 and larger may "cup" (deform in a dish-like shape) under high preload.
- Thicker washers also serve to spread the clamping force over a larger volume of fitting material.
  - Increases joint stiffness and reduces cyclic loading in the bolt

NASA-STD-5020B, Sec. 4.8.1d:

The engineering documentation shall specify ... the types, locations, and allowable quantities of washers.

## Countersunk Washers Avoid Interference with Head-to-Shank Radius

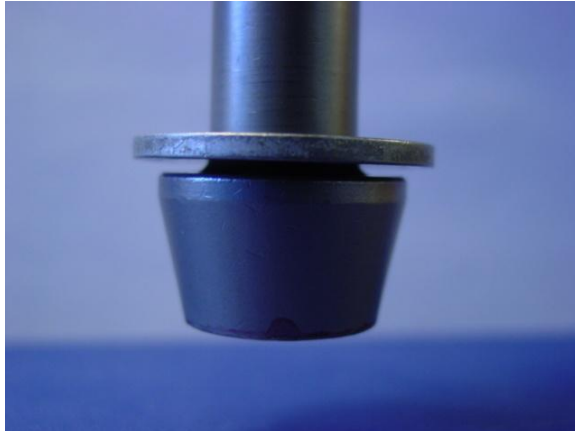

NASA-STD-5020B, Sec. 4.7.3:

Clearance shall be provided for the head-to-shank fillet radius as needed to avoid interference with the clamped parts through the use of chamfered holes or countersunk washers installed under bolt heads with the countersink facing the bolt head.

**But there's a dilemma here for socket-head cap screws:** The under-head radius leads to likely interference with a plain washer, but the head has a small diameter. A standard countersunk washer doesn't leave much contact surface area between the head and the washer (possible galling under high contact stress). Options:

1. Order a custom countersunk washer with a smaller countersink.
2. Use a 300-series SS plain washer and accept the potential interference and washer yielding—and the wider range of variation in preload for given torque.

**When there is potential interference, don't use a washer (or other part without a countersink) made of a high-strength material or the interference may lead to (a) galling when torquing, and subsequent low preload, or (b) bolt failure.**

## Bolt Features and Geometry

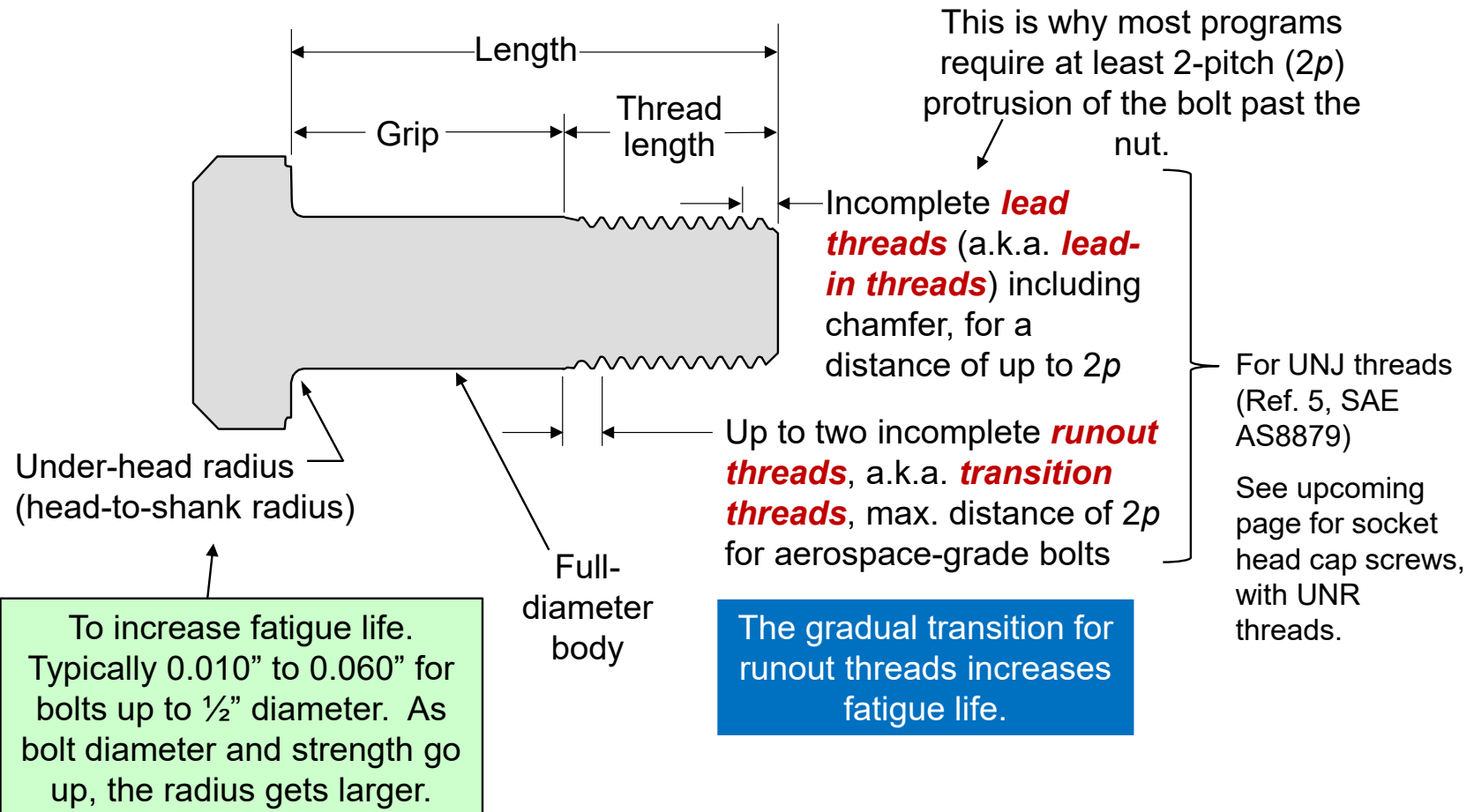

## Runout Threads and Lead Threads per AS8879 (UNJ)

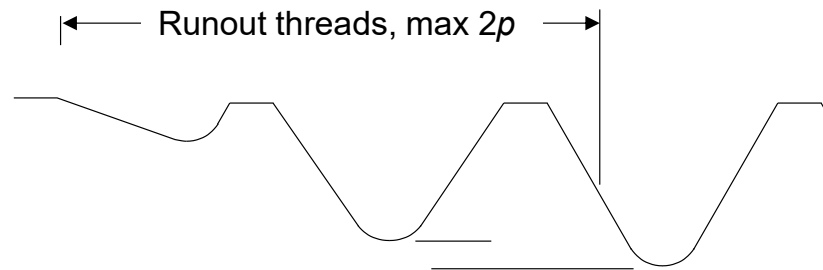

“Unless otherwise specified, threads on externally threaded parts shall terminate between one and two pitches from the start of the unthreaded section, end of full form thread, or fillet radius, as applicable. The root radius of the incomplete thread shall be greater than or equal to the minimum root radius ...” (Ref. 5, SAE AS8879)

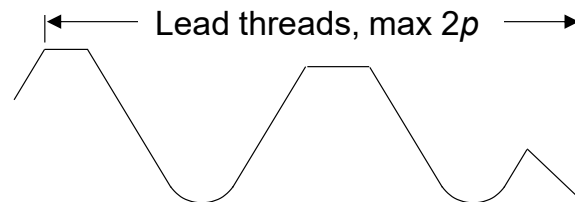

“Unless otherwise specified, the entering end of external threads and internal threads may be outside the specified limits of size for a length not to exceed two pitches, including chamfer. In no case shall the lead threads exceed the specified maximum material condition.” (Ref. 5, SAE AS8879)

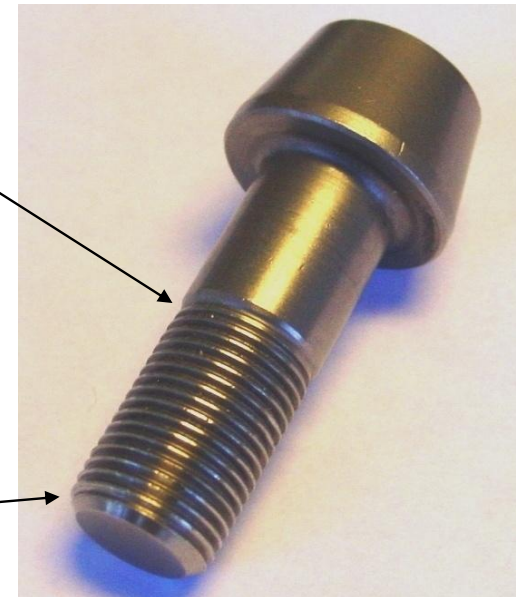

(Drawings adapted from Ref. 37, NAS 498)

## Dimensions for Relatively Long\* Socket Head Cap Screws

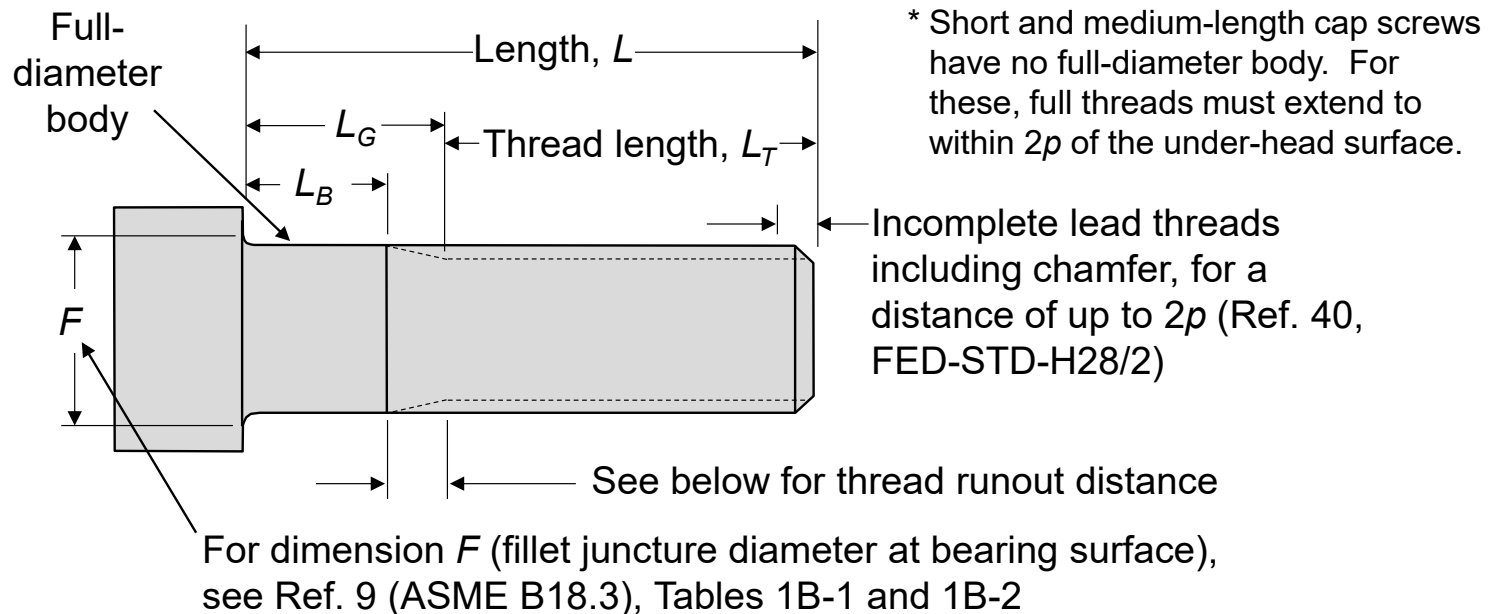

$L_B$  is minimum distance from under-head surface to the end of the full-diameter body  
 $L_G$  is maximum distance from under-head surface to the first complete thread

Per Ref. 9, Table 1C, which specifies  $L_G$  and  $L_B$ , Note (a):

$$L_G - L_B = 5 \text{ times the pitch of the coarse thread (UNRC) for the applicable bolt diameter} \\ \text{(applies for fasteners with UNRC threads and those with UNRF threads as well)}$$

## Use Care in Selecting Bolt Length and Grip

Common problems:

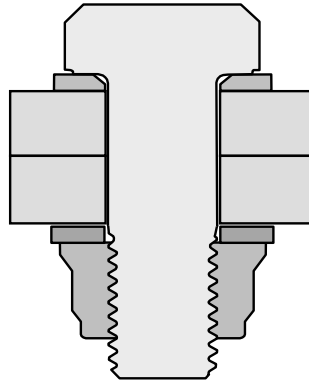

Nut riding up onto the runout threads, leading to little or no preload.

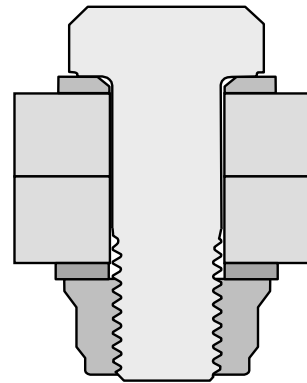

(a) Threads in bearing (okay for a tension joint) and (b) not enough extension past the nut—lack of full thread engagement

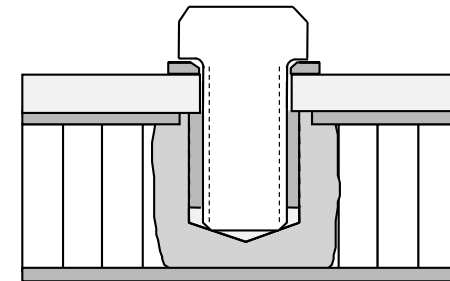

Screw bottoming in a blind hole

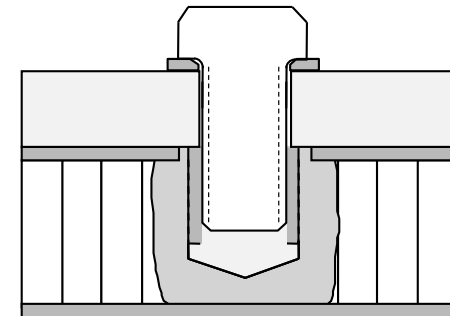

Screw inadequately engaging insert

**These problems are common and can lead to failure.**  
**Control dimensions by design to the extent practical and make sure the people assembling flight hardware are trained to watch for such problems.**  
**Don't rely on either process—design or assembly—alone!**

## Example of the Importance of Attending to Details: Case History, 1988—Shuttle External Tank, Michoud Assembly Facility

A design engineer was walking the factory floor, looking at the structure he had designed, and he noticed something that didn't look right: A bolt protruded too far past the nut.

He had the joint checked, and it was found that nut had ridden up onto the bolt's runout threads. The bolt had been torqued, but the joint was not preloaded.

How had this happened? The assembly procedure said, "Use between one and three washers under the nut as needed to prevent shanking."

There was only one washer under the nut.

When questioned, the technician responded, "What's 'shanking'?"

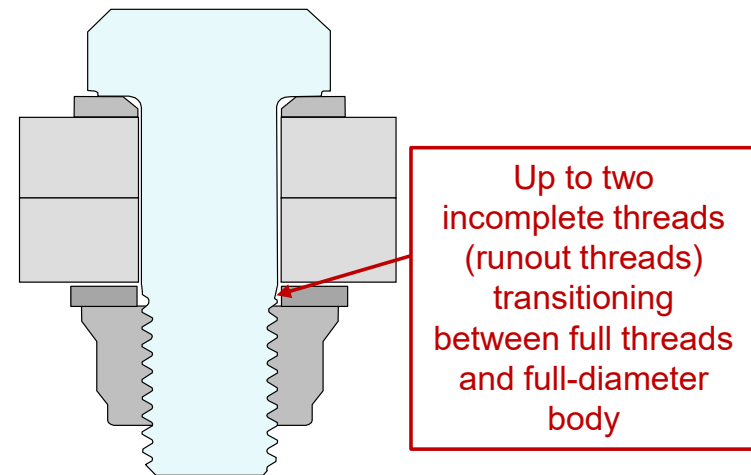

**This problem had a four-million-dollar impact, as each bolted joint in the factory needed to be investigated!**

## Lessons from the External Tank Case History

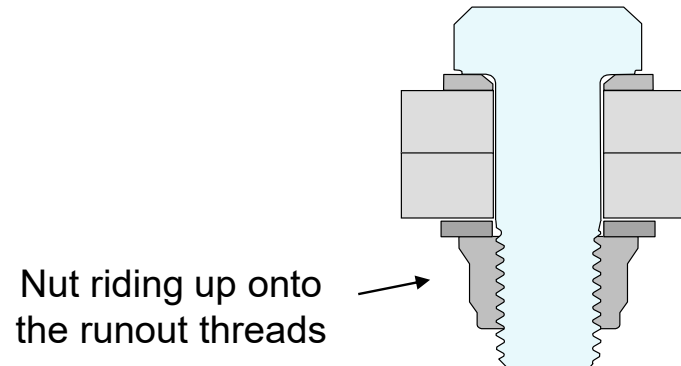

### **Lesson: Putting instructions in assembly procedures is not enough to ensure quality!**

- The design engineer should be responsible for designing a joint that works—considering bolt grip and length, number of washers, part thicknesses, and tolerances—instead of putting the responsibility on the technician.
- To protect against human error and the rare design in which doing the above is impractical, make sure the people assembling flight hardware are craftsmen.
- Assign a responsible engineer—if you are that engineer, make sure your hardware is assembled properly. Visit the assembly area often.

## Dimensional Considerations for Floating Fasteners

Washer under head, with countersink if needed to accommodate head-to-shank radius

Slightly modified version of NASA-STD-5020B Fig. 2

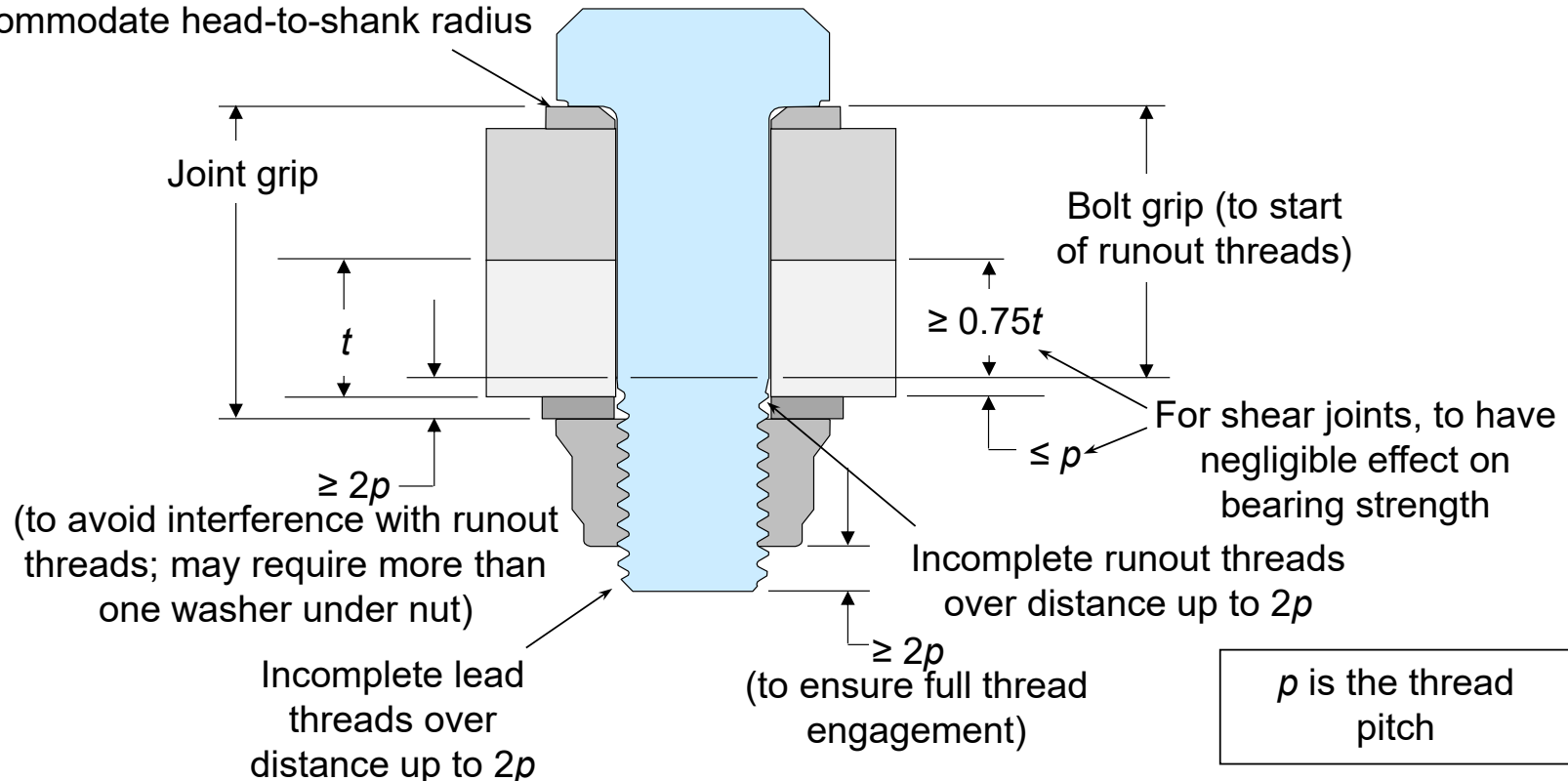

See appendix for dimensional considerations with threaded inserts

## NASA-STD-5020B Requirements Regarding Bolt Length and Grip

### Sec. 4.7.4:

When the threaded fastening system incorporates a prevailing torque locking feature, the fastener length shall be sufficient for fully formed threads to engage the locking feature.

*To ensure that all internal threads are fully engaged, the length of each fastener used with a nut, nut plate, or insert should be selected to extend a distance of at least twice the thread pitch,  $p$ , past the outboard end of the nut, nut plate, or insert.*

### Sec. 4.7.5:

- a. For a fastener with a full diameter body, the bolt grip and the number and type of washers shall be selected to ensure the internal threads do not encroach on the incomplete runout threads of the fastener.
- b. Fasteners threaded into blind holes shall be selected to prevent contacting the bottom of the hole or interfering with incomplete internal threads.

### Sec. 4.8.1: The engineering documentation shall specify:

- a. The part or identifying numbers of fastening system hardware
- c. Dimensions and tolerances necessary to manufacture and assemble the fastened joint and its constituent parts.

## Example Problem 7-a: Matching Hardware Dimensionally

**Problem statement: Check whether the dimensions of the bolt and nut shown are compatible.**

Units: inch

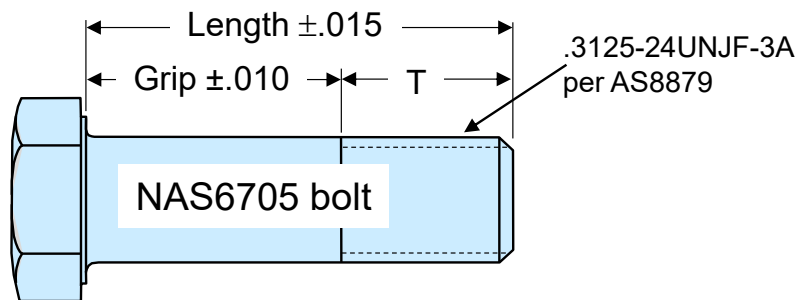

Length and grip are specified;  $T$  is a reference dimension nominally equal to 0.469 for this bolt.

The above tolerances are typical for bolts such as this one. For NAS1351 and 1352 socket head cap screws, the tolerance on length is +0.000/-0.030 or greater.

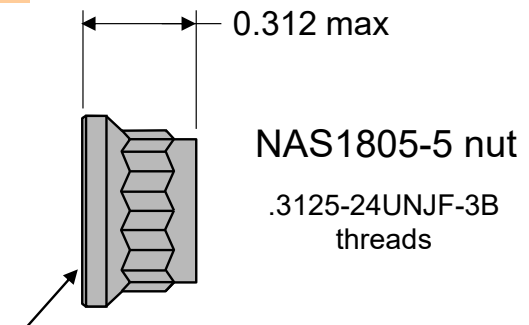

Chamfer (countersink) at lead thread, with minimum diameter of 0.312"; min. chamfer depth\* of 0.012" through which there would be no interference with the bolt's runout threads. So max. effective nut height for thread engagement is  $0.312 - 0.012 = 0.300$ ".

\*Calculations:

Chamfer angle is not specified, but I assume it's 120° to match the thread angle. Minor diameter of internal thread,  $d_{i\text{-minor}}$ , is 0.2719 (minimum).

$$a = \frac{.312 - .2719}{2} = .02005 \quad (.02005) \tan(30^\circ) = .012$$

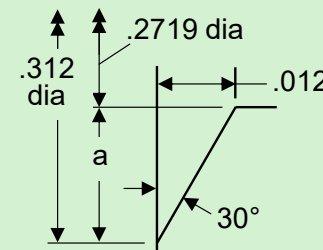

continued

## Example Problem 7-a: Solution

Threads are imperfect for a distance up to  $2p$  from the end of the fastener and also from the end of the full-diameter body, as defined by grip, so the nut must lie in between to ensure no interference and full thread engagement.

Pitch,  $p = 1/24 = 0.0417$   
 $2p = 0.083$

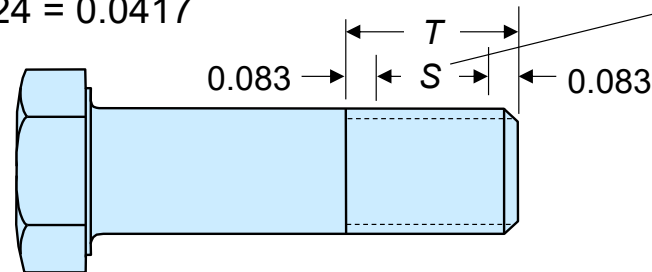

We want the nut to lie fully within dimension  $S$

Units: inch

Using the nominal value for  $T$  (0.469),

$$S = 0.469 - 2(0.083) = 0.303, \text{ which is only } 0.003 \text{ greater than the } 0.300 \text{ effective nut height}$$

**Given dimensional tolerances, this is not a good combination!**

Unfortunately, this type of combination is often used. Inspecting to make sure such a bolt protrudes at least  $2p$  past the nut leads to potential interference with the runout threads—and little or no preload.

**It's often not easy to match hardware. Standardize fasteners and combinations once you find ones that work!**

## Example Problem 7-b: Selecting Bolt Length

**Problem statement: For the design shown, select the bolt dash number**

Tension joint (negligible shear)

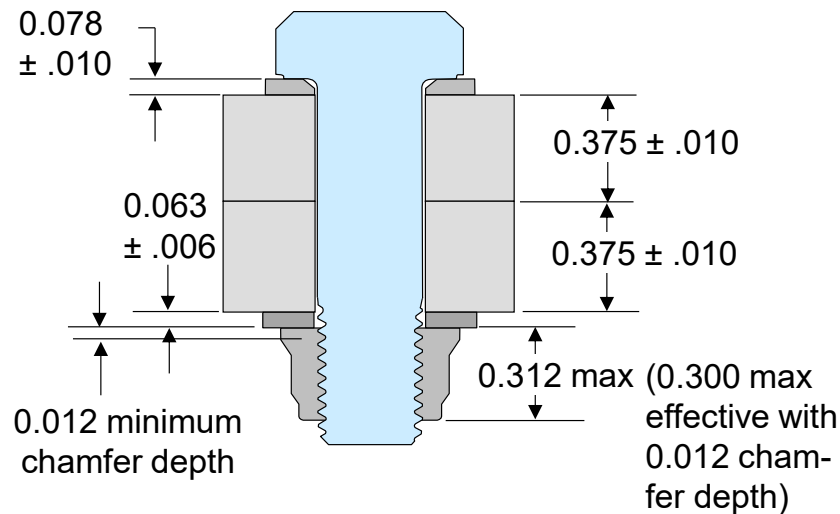

For this problem, we'll ignore the effect of bolt stretch under preload, which will only be a few thousandths of an inch for this joint. In some cases, bolt stretch can be more significant.

Units: inch

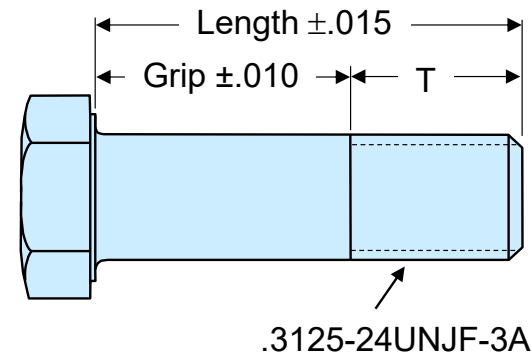

Available lengths:

<u>Dash no.</u>	<u>Grip ± 0.010</u>	<u>Length ±.015</u>
8	.500	1.072
10	.625	1.197
12	.750	1.322
14	.875	1.447
16	1.000	1.572

continued

## Example Problem 7-b, continued

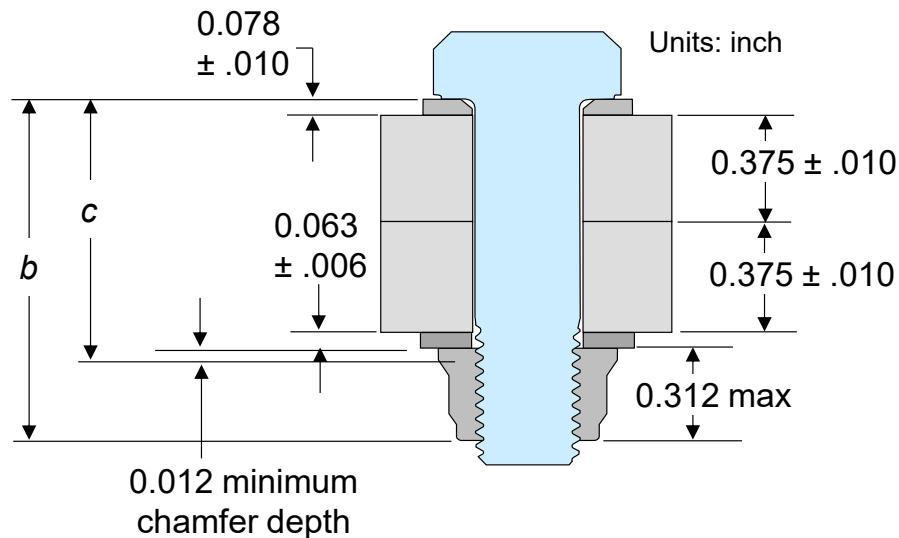

We need to know the minimum value for dimension  $c$ , which will establish the bolt's maximum grip to ensure the nut doesn't get within two  $2p$  of the full-diameter body, where  $p$  is the thread pitch.

We also need the maximum value for  $b$ , which will establish the minimum length as we ensure the bolt protrudes past the nut a distance of at least  $2p$ .

With 24 threads per inch,  $p = 1/24 = 0.0417$ ,  $2p = 0.083$

$$c_{\min} = (0.078 + 0.375 + 0.375 + 0.063 + 0.012) - (0.010 + 0.010 + 0.010 + 0.006) = 0.867$$

$$b_{\max} = (0.078 + 0.375 + 0.375 + 0.063 + 0.312) + (0.010 + 0.010 + 0.010 + 0.006) = 1.239$$

Because this is a tension joint, we don't have to worry about threads in bearing. Doing so would complicate this problem further.

continued

## Example Problem 7-b, continued

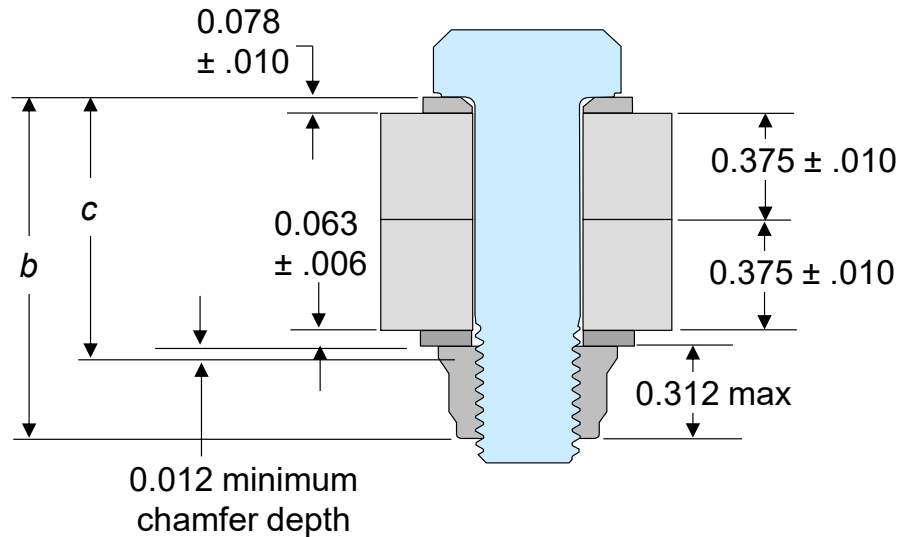

$$c_{\min} = 0.867 \quad b_{\max} = 1.239$$

Maximum grip is thus

$$\begin{aligned} Grip_{\max} &= c_{\min} - 2p \\ &= 0.867 - 0.083 = 0.784 \end{aligned}$$

and minimum length is

$$\begin{aligned} Length_{\min} &= b_{\max} + 2p \\ &= 1.239 + 0.083 = 1.322 \end{aligned}$$

Available lengths:

<u>Dash no.</u>	<u>Grip ±0.010</u>	<u>Length ±.015</u>
8	.500	1.072
10	.625	1.197
12	.750	1.322
14	.875	1.447
16	1.000	1.572

Nominally, it looks like a -12 will work, but not if we include the +/-0.015 tolerance on length.

**Let's look at our options for solving this problem ...**

continued

## Example Problem 7-b, continued: Options

1. Slightly increase the nominal thickness of one or both joint members (load-bearing parts).
  - Not desirable if this a weight-critical design.
2. Tighten the tolerances on the joint members.
  - With computerized machining, we should be able to go to +/-0.005 without driving additional cost.
  - Does not solve the problem in this case, though, at least not by itself.
3. See if adding a washer solves the problem.
  - But remember, each washer has a tolerance on thickness.
4. Consider requiring only  $1.5p$  extension past the nut rather than  $2p$ .
  - It can be argued that the risk of inadequate strength or of not fully engaging the locking feature is lower than the risk associated with interfering with the runout threads and having no preload.
5. Be less conservative in stacking tolerances.
  - See next page ...

## Example Problem 7-b, continued: Pursuing Option 5

We are being conservative to start with by assuming (1) a full distance of  $2p$  for imperfect threads at two locations, (2) maximum nut height, and (3) minimum lead chamfer on the nut.

We may be able to convince ourselves that it's okay to RSS the remaining tolerances.

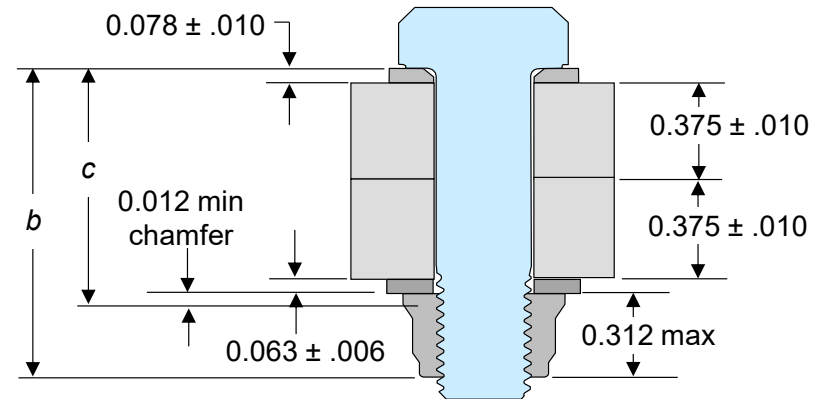

$$c_{\min} = (0.078 + 0.375 + 0.375 + 0.063 + 0.012) - \sqrt{3(0.010)^2 + (0.006)^2 + (0.010)^2}$$

← Grip tolerance

$$= 0.903 - 0.021 = 0.882$$

$$Grip_{\max} = c_{\min} - 2p = 0.882 - 0.083 = 0.799 \text{ vs. } 0.750 \text{ for the } -12 \text{ bolt}$$

← Length tolerance

$$b_{\max} = (0.078 + 0.375 + 0.375 + 0.063 + 0.312) + \sqrt{3(0.010)^2 + (0.006)^2 + (0.015)^2}$$

$$= 1.203 + 0.024 = 1.227$$

$$Length_{\min} = b_{\max} + 2p = 1.227 + 0.083 = 1.310 \text{ vs. } 1.322 \text{ for } -12$$

Because we've included bolt tolerances, we can compare these values with the bolt's nominal dimensions, which means a -12 is acceptable.

Some problems require use of 2 or 3 washers under the nut. The best solution may be to tighten the tolerances on part thickness.

## **Recommendation for Avoiding Problems with Thread Engagement**

**Use fully threaded fasteners if you can keep threads out of bearing!**

- By using a dedicated shear-transfer device, such as a shear pin
- Or by designing to ensure friction will carry the limit shear load.  
(Discussed in Sec. 9)

## Guidelines for Simplifying Assembly from Lou Arthur

- Design to avoid the need for drilling at high levels of assembly, especially in a clean room.
  - Such drilling can be time consuming and risks particulate contamination.
  - Match drilling should be done at low levels of assembly (must design for this).
- Standardize fastening hardware.
  - Establish a list of “approved” hardware.
  - Stock spares.
- Make sure the installation torque is achievable.
- Plan on multiple installations and removals of fasteners.
  - Match thread forms
  - Lubricate threads to avoid galling
  - Locking feature on the separable part
- Provide adequate clearance for wrenches.

**Spend time in the assembly area so you'll build an appreciation of how your design decisions drive cost.**

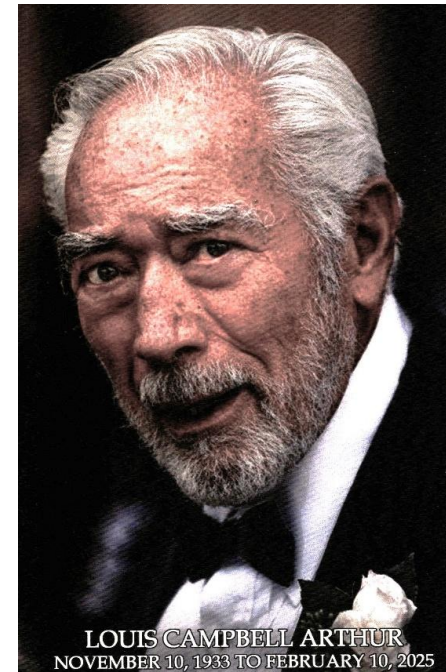

LOUIS CAMPBELL ARTHUR  
NOVEMBER 10, 1933 TO FEBRUARY 10, 2025

Designer of the Voyager  
spacecraft structure

## Example of Inadequate Wrench Clearance



Here they are torquing the bolt head rather than the nut. Why is it better to torque the nut?

**When torquing the bolt head, the full-diameter body turns and can rub against the surfaces of the bolt holes, causing variable friction loss and leading to more variation in preload.**

## Methods of Establishing Preload

- Specifying an installation torque (**torque method** or **torque control**)—the most commonly used method
  - Simple, but not accurate for controlling preload (typically +/- 25% to 50% scatter in preload as a result of many variables)
- Specifying a turn angle to be applied after the nut is snug
  - Can be somewhat more accurate than torque control (depends on who you ask!)
  - More time consuming, thus more expensive, than torque control
- Methods that noticeably increase accuracy but increase cost:
  - Load cell (typically used in the lab only)
  - Measuring shank strain
  - Measuring bolt length change (can achieve preload knowledge within a few percent when using ultrasonic methods)

**Recommendation: Keep assembly simple by using the torque method, and design the joint to be tolerant of preload uncertainty.**

**When you must control preload accurately, use a more-dependable method, such as measuring bolt length change.**

## The Torque Method for Establishing Preload

Preload tends to be nearly proportional to torque. A simple equation applies regardless of thread form:

$$T = KDP_{pi} \quad \text{or} \quad P_{pi} = T/KD$$

$T$  = effective torque = total torque minus **running** (a.k.a. **run-in** or **locking**) **torque** (resisting torque caused by interference from locking feature)

$D$  = bolt nominal diameter

$P_{pi}$  = initial preload (subject to relaxation, creep, and thermal effects; see Secs. 8 and 9)

$K$  = **nut factor** (a.k.a. **torque coefficient**), which accounts for geometry, friction, and other variables; derived from test data

Multiple references state that the nut factor for steel fasteners ...

- installed without lubrication tends to be about 0.2
- when lubricated tends to be about 0.15

} Let's refer to this as the **nominal nut factor**,  $K_{nom}$

However, it is unwise to count on these values for two reasons:

1. Depending on mating materials, lubricant, lubrication process, and other variables,  $K_{nom}$  can be significantly different than the above values.
2. For any given installation,  $K$  can vary widely from  $K_{nom}$ .

See Sec. 9 for related criteria per NASA-STD-5020B

## Example Variation in the Torque-Preload (aka Torque-Tension) Relationship

Ten screws tested, 3 cycles each, the last cycle to failure  
(Source: Ref. 30)

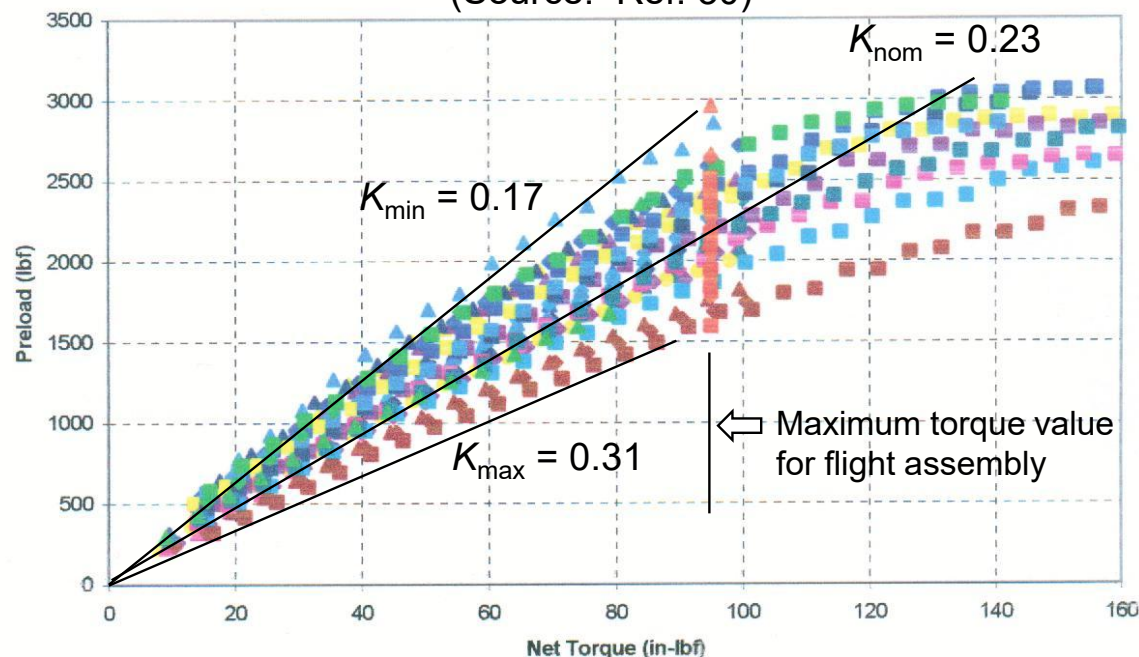

#10 NAS1351, UNRF-3A, A-286 screw in an MS21209 corrosion-resistant steel helical coil insert, with an NAS620C10L washer. No lubricant. Each screw was installed in a fresh insert for the first cycle. “Net torque” (referred to as “effective torque” herein and in NASA-STD-5020B) on the horizontal scale is the amount above running torque from the locking feature.

Most tests such as this are done with fastening hardware that comes from a single procurement lot.

There can be significant variation between lots or suppliers.

This is especially true for socket-head cap screws such as these. The A-286 screws have no requirement for surface roughness. Many of these screws are grit-blasted, resulting in a wide range of surface roughness, which affects the nut factor. (See Appendix 7A.2 herein for sample test data.)

## The Lubrication Process Affects the Nut Factor

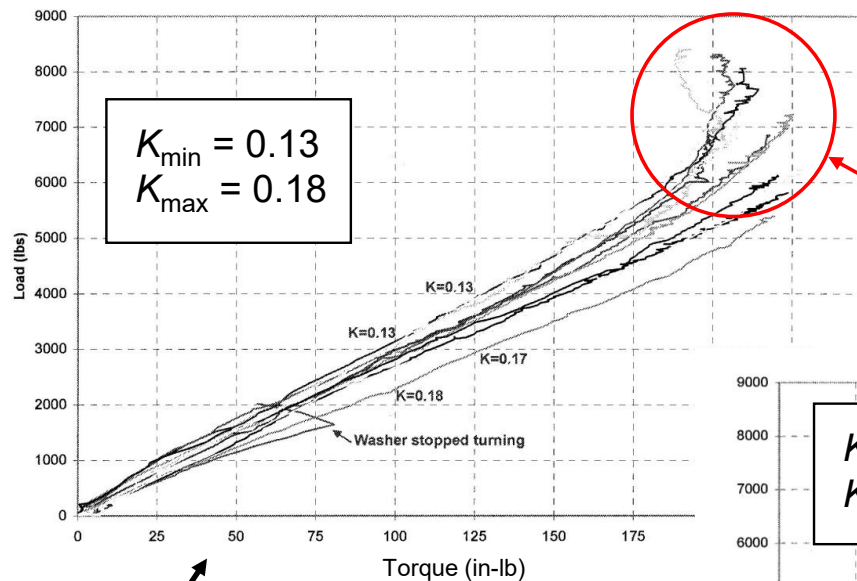

1/4" NAS1954C12 A-286 180-ksi bolts, with an NAS1805 A-286 nut and an NAS1587-4C washer under the nut (torque applied to nut)

(Source: Ref. 31)

Clearly something is wrong with this data; not addressed in the report

Bolt threads sprayed with Miller Stephenson (MS-122AD) lubricant.

Bolt threads sprayed with MS-122AD lubricant, as above. Epoxy primer applied under bolt head, under nut, and on washers.

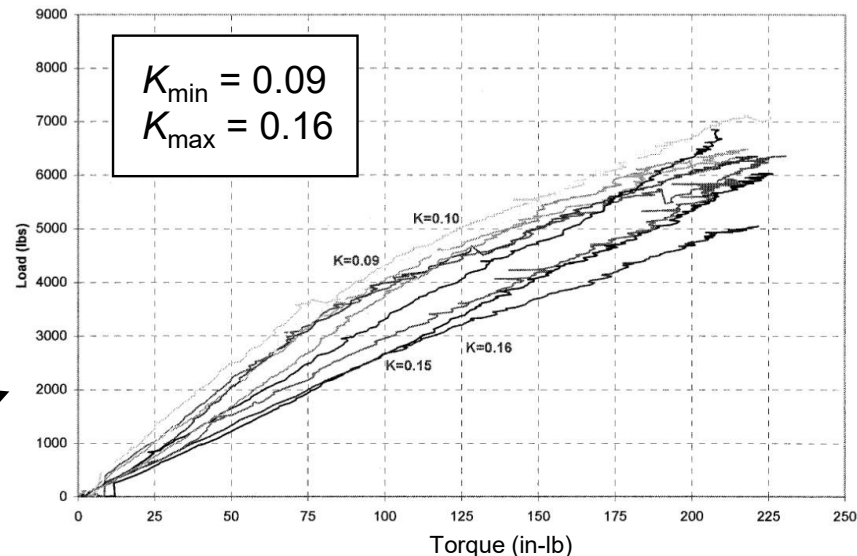

## Torque-Preload Data for Small Fasteners (#2 through #6)

Most available torque-preload data is from testing of fasteners of size #10 and larger.

- Difficult to measure preload for smaller bolts.
- As fasteners get smaller, it's not clear that the same nut factor would apply (e.g., imperfections in geometry may make a bigger difference).

In 2008, NASA Goddard tested small screws (#2 through #6) installed in Heli-Coils (Ref. 36).

- Devised a reliable method of testing.
- NAS 1149 washers, 300-series stainless

B-Basis: 90% probability  
at 95% confidence

Installed in silver-plated CRES Heli-Coils:

Screw Material	Wet Lubrication*				Dry			
	Sample Size	$K_{nom}$	B-Basis $K_{min}$	B-Basis $K_{max}$	Sample Size	$K_{nom}$	B-Basis $K_{min}$	B-Basis $K_{max}$
A286	48	0.165	0.134	0.197	45	0.422	0.259	0.585
300 SS	36	0.180	0.137	0.224	36	0.413	0.273	0.552

Installed in Phosphor Bronze Heli-Coils:

Screw Material	Wet Lubrication*				Dry			
	Sample Size	$K_{nom}$	B-Basis $K_{min}$	B-Basis $K_{max}$	Sample Size	$K_{nom}$	B-Basis $K_{min}$	B-Basis $K_{max}$
A286	48	0.169	0.129	0.210	46	0.373	0.233	0.513
300 SS	36	0.174	0.136	0.211	36	0.339	0.290	0.387

\*Lubrication: Braycote 601EF grease (spaceflight approved) applied to threads and under head of fastener

## Test Data for Titanium Bolts

Bolts: SP7121V3-17TF (old TRW spec replaced by NAS9921V3), #10 titanium, 160-ksi  
 Nuts: MS21043-3, A-286, silver plated, rated for 125 ksi bolts (a mismatch!)  
 Washers: NAS1149C0332R, under nut and bolt head  
 Lubrication: Dry-film lubricant on bolt threads  
 Torque: 45 +/- 2.5 in-lb

Results of 10 tests per case:  
(derived from Ref. 32)

	$K_{\min}$	$K_{\text{nom}}$	$K_{\max}$
Torque applied to nut, 1 washer under nut	0.11	0.14	0.15
Torque applied to nut, 2 washers under nut	0.15	0.17	0.18
Torque applied to nut, 3 washers under nut	0.15	0.18	0.19
Torque applied to bolt, 1 washer under nut	0.12	0.15	0.16
Torque applied to bolt, 2 washers under nut	0.15	0.17	0.20
Torque applied to bolt, 3 washers under nut	0.15	0.18	0.21

**In this test, more washers led to less preload.**

**However, in a test conducted by NASA/JSC (Ref. 30), the opposite effect was observed.**

## Why Bolts Lose Preload

- Short-term relaxation
  - Usually attributed to embedment from local yielding of high points on rough surfaces
- Relative rotation between nut and bolt (or bolt and insert)
  - Usually the result of cyclic slip (overcoming friction)
- Wearing down of high points on rough surfaces as a result of cyclic slip
- Temperature change (addressed in Sec. 8)
  - Preload changes as a result of mismatched coefficients of thermal expansion.
- Material yielding under applied loading or temperature change
  - Bolt, threads, washer, material under washer
- Material creep
  - Bolt (only a high-temperature concern for most high-strength bolt materials)
  - Clamped material (normally a concern only at high temperatures or with non-metallic materials; can be significant with peelable shims because of the adhesive)
- Elastic interaction in joints with multiple fasteners
  - Tightening one fastener affects the preload in the others. (Preload usually drops in neighboring bolts.)
  - Use an iterative tightening process, as you do for the lug nuts when changing a tire.

## Why Do Preloaded Nuts and Screws Rotate Relative to Each Other?

Vibration by itself doesn't cause relative rotation in a preloaded fastening system.

Relative rotation tends to occur when preloaded thread surfaces slip under lateral loading (Haviland\* theory, refs. 14 & 33).

Analogy: if you push a brick laterally on a ramp, it will also slide down the ramp.

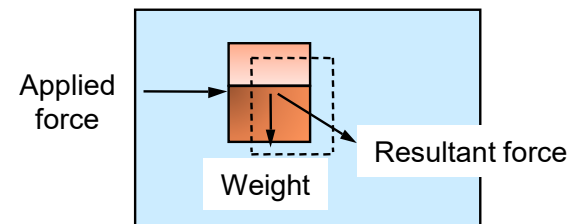
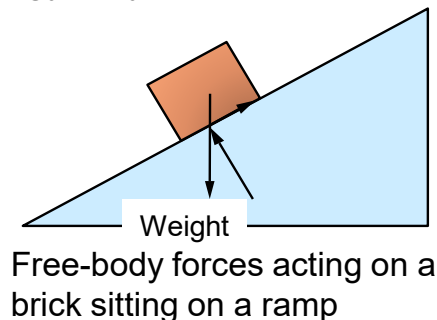

When the resultant force overcomes friction, the brick moves across and down the ramp.

There's almost always a little lateral space between mating threads. Lateral motion (when the lateral force overcomes friction) causes the nut to rotate relative to the bolt as the threads "slide down the ramp" of the helical thread.

**The main purpose of a locking feature is to keep hardware from spinning off completely. The locking features most effective at maintaining preload are those that prevent lateral motion at the threads.**

\*Girard S. Haviland of Loctite Corporation

## Commonly Used Locking Features

**“Lock washers”** (split, helical-spring rings)—used around the house, but not for flight hardware!

- Once fully compressed, they act like normal washers under preload
- If the washer fully relaxes, nothing prevents the nut or bolt from spinning off completely



**Prevailing-torque locking feature** (prevailing torque is often referred to as “running torque” or “run-in torque”)

- The most commonly used locking feature in aerospace
- Can be a deformity, such as ovalization of the end of the nut, or use of nylon patches, pellets, or strips
- Reliably prevents fasteners from backing out completely
- However, it does not maintain preload if the joint slips back and forth in shear (Refs. 14, 21, and 27)



Nylon strip



Nylon patch

Continued

## Commonly Used Locking Features



Lock wire

**Mechanical locking features:** lock wire, safety cable, and cotter pins

- Very reliable for keeping nut from falling off bolt and for losing all preload
- But not for retaining full preload
- Additional labor needed for installation

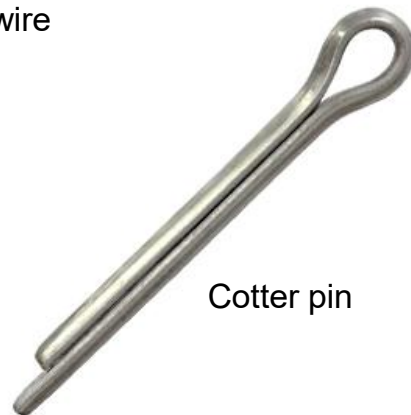

Cotter pin

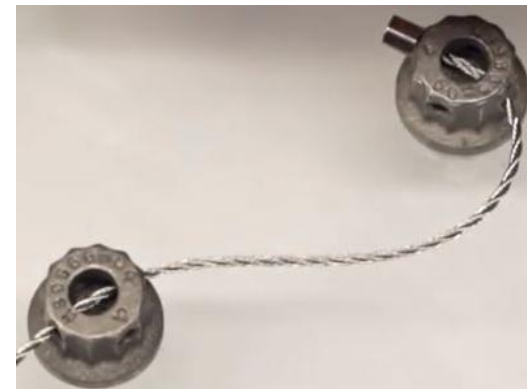

Safety cable being installed

Continued

## Commonly Used Locking Features (continued)

### **Liquid thread fillers and locking compounds**

- Prevent relative rotation by a combination of adhesion and filling space between threads.
  - Tests show that, if properly cured, they maintain preload much better than prevailing-torque locking features in joints subject to cyclic slip.
- Anaerobic adhesives such as Loctite® cure in the absence of oxygen.
  - Whether they properly cure is process dependent; entrapment of air in blind holes can prevent proper cure. If the adhesive remains in liquid form, it does not work.
- Polyurethanes such as Arathane® and Solithane® cure both in and out of the presence of oxygen and are gummy when cured.

### **Epoxy head staking**

- Glob of epoxy over bolt head and onto joint member; also must cure and adhere
- Considered a low-reliability locking feature (NASA-STD-5020B Appendix B.5.1.b)
- Often used for small screws that are enclosed within electronics boxes (See requirements in Ref. 11, NASA-STD-8739.1B)

See NASA-STD-5020B, Appendix B for additional guidance on locking features.

## Spirallock™ Threads

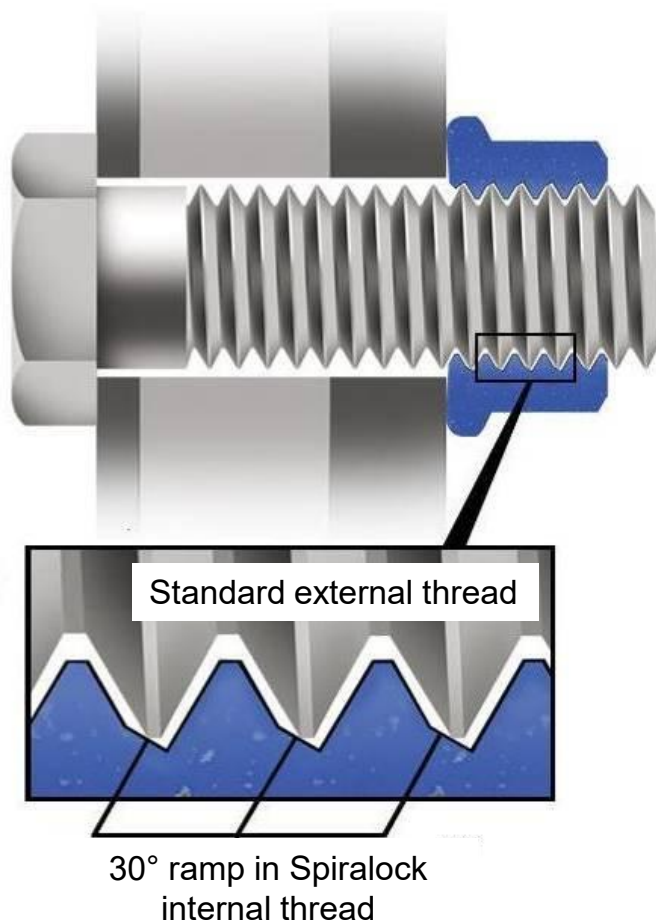

- Internal thread that incorporates a 30° ramp, which prevents lateral relative motion when preloaded
- Tests show they maintain preload very well.
- NASA-STD-5020B does not permit Spirallock as the sole locking feature because locking is dependent on preload and the locking feature is not verifiable.
- But Spirallock threads can be combined with a prevailing-torque locking feature.
  - Prevailing torque satisfies NASA-STD-5020B.
  - Spirallock retains preload.

Image courtesy Stanley Engineered Fastening, which provides Spirallock

## NASA-STD-5020B Requirements for Locking Features

- Sec. 4.6.1: Regardless of the magnitude of preload, each threaded fastening system in spaceflight hardware shall incorporate a minimum of one locking feature that does not depend upon preload to function.
- 4.6.2. A mechanical locking feature shall be used on any bolt subject to rotation in operation (*serves as an axis of rotation between mating parts*).
- 4.6.3. When using locking adhesives, whether as thread-locking compounds or staking materials, installation processes shall be developed and validated prior to implementation to ensure adhesives cure, adhere, and function as expected.
- 4.6.4. The presence and performance (locking moment) of locking features shall be verified using the methods of Table 4, Locking Feature Torque Verification.

See next page for NASA-STD-5020B Table 4.

See NASA-STD-5020B Appendix B for guidance regarding locking features.

## NASA-STD-5020B Table 4, Locking Feature Torque Verification

Locking Feature Type	Method
Mechanical <i>(including, but not limited to, cotter pins, safety wire, and safety cable)</i>	Visual inspection after installation
Prevailing Torque <i>(including, but not limited to, deformed thread features and non-metallic pellets, strips, or patches)</i>	Torque measurement during installation <sup>(1)</sup>
Liquid Locking Compounds <i>(including, but not limited to, adhesives, sealants, thread lockers, and chemical thread pre-coats that are applied to the threads and cured prior to joint assembly)</i>	Torque measurement on witness specimens using the same materials and processes, and processed at the same time, as the hardware being verified <sup>(2)</sup>

<sup>(1)</sup>Verification of prevailing torque locking features by torque measurement may be omitted with prior approval of the delegated NASA Technical Authority if loss of fastener does not credibly cause a catastrophic hazard and if other controls are utilized to minimize the likelihood of assembly with inadequate locking features. Examples of such controls are fastener lot acceptance testing of locking feature performance, locking feature surveillance with periodic measurement of prevailing torque on like fasteners in flight hardware assemblies, technician training to recognize when no prevailing torque is present, etc. The rationale for this approach needs to properly consider fastener reuse if fastener reuse is permitted in the flight assembly. Preloaded joint analyses cannot assume a specified torque ‘above running torque’ if prevailing torque is not measured. Relaxation of this verification requirement is generally intended for secondary or tertiary structures such as P-clamps.

<sup>(2)</sup>For adhesive locking features that are not sensitive to the threaded fastening system materials or configuration, cure samples processed at the time of application/processing may be used for verification.

## Maintaining Preload with Prevailing-Torque Locking Features

Prevailing-torque locking features usually prevent rotation and maintain preload as long as there is no relative lateral motion between the bolt and the nut or insert.

We can minimize lateral motion by ...

- using interference-fit shear pins or other such features to transfer shear
- or match drilling and reaming to get tight bolt holes
- or designing the joint so that friction will carry the shear load without slipping
  - High clamp load; uncoated, cleaned metal surfaces
  - Practical only for joints with relatively low applied shear

**How concerned should we be about potential preload loss?**

**The answer depends on the number of expected slip cycles.**

**Tests of fasteners in locking Heli-Coils® showed average preload loss of approx. 30% after 500 slip cycles and 70% after 1000 slip cycles (ref. 21).**

**Joints slip more freely as preload relaxes. The more we allow joints to slip back and forth, the less predictable and reliable our structure becomes!**

**Suggestion: Torque stripe critical fasteners prior to vibration testing, and retorque those that show evidence of rotation. (Back off first, then retorque.)**



## Key Points from Sec. 7

- Make sure the materials for fastening hardware are compatible with environments and mating materials and are approved for program use.
  - Prevent galling by material selection, coatings, and lubrication.
- Match the strength of the nut or insert to that of the bolt.
- Make sure washers are appropriate for the application.
- Account for dimensional details to ensure a good joint.
  - In particular, make sure the internal threads don't encroach on the fastener's incomplete runout threads.
- Once you find combinations of fastening hardware that are compatible with the environment, joint materials, and each other (strength and dimensions), standardize them at your organization!
- Design for assembly.
- Recognize that you won't know the preload very accurately for a specified torque, so design the joint to work despite the uncertainty.
- Most locking features are meant to keep hardware from spinning off completely, so to retain preload you'll have to design the joint properly.

## **Appendices to Section 7**

- 7A.1 Miscellaneous Design Data and Information
- 7A.2 Additional Torque-Preload Test Data



## Appendix 7A.1—Miscellaneous Design Data and Information: Standard Inch-based Drill Sizes and Hole Tolerances

Drill	Decimal	Drill	Decimal	Drill	Decimal	Drill	Decimal	Drill	Decimal	Drill	Decimal	Drill	Decimal	Drill	Decimal
80	.0135"	59	.0410"	40	.0980"	21	.1590"	2	.2210"	P	.3230"	33/64	.5156"	49/64	.7656"
79	.0145"	58	.0420"	39	.0995"	20	.1610"	1	.2280"	21/64	.3281"	17/32	.5312"	25/32	.7812"
1/64	.0156"	57	.0430"	38	.1015"	19	.1660"	A	.2340"	Q	.3320"	35/64	.5469"	51/64	.7969"
78	.0160"	56	.0465"	37	.1040"	18	.1695"	15/64	.2344"	R	.3390"	9/16	.5625"	13/16	.8125"
77	.0180"	3/64	.0469"	36	.1065"	11/64	.1719"	B	.2380"	11/32	.3437"	37/64	.5781"	53/64	.8281"
76	.0200"	55	.0520"	7/64	.1093"	17	.1730"	C	.2420"	S	.3480"	19/32	.5937"	27/32	.8437"
75	.0210"	54	.0550"	35	.1100"	16	.1770"	D	.2460"	T	.3580"	39/64	.6094"	55/64	.8594"
74	.0225"	53	.0595"	34	.1110"	15	.1800"	E	.2500"	23/64	.3594"	5/8	.6250"	7/8	.8750"
73	.0240"	1/16	.0625"	33	.1130"	14	.1820"	1/4	.2500"	U	.3680"	41/64	.6406"	57/64	.8906"
72	.0250"	52	.0635"	32	.1160"	13	.1850"	F	.2570"	3/8	.3750"	21/32	.6562"	29/32	.9062"
71	.0260"	51	.0670"	31	.1200"	3/16	.1875"	G	.2610"	V	.3770"	43/64	.6719"	59/64	.9219"
70	.0280"	50	.0700"	1/8	.1250"	12	.1890"	17/64	.2656"	W	.3860"	11/16	.6875"	15/16	.9375"
69	.0292"	49	.0730"	30	.1285"	11	.1910"	H	.2660"	25/64	.3906"	45/64	.7031"	61/64	.9531"
68	.0310"	48	.0760"	29	.1360"	10	.1935"	I	.2720"	X	.3970"	23/32	.7187"	31/32	.9687"
1/32	.0313"	5/64	.0781"	28	.1405"	9	.1960"	J	.2770"	Y	.4040"	47/64	.7344"	63/64	.9844"
67	.0320"	47	.0785"	9/64	.1406"	8	.1990"	K	.2811"	13/32	.4062"	3/4	.7500"	1	1.000"
66	.0330"	46	.0810"	27	.1440"	7	.2010"	9/32	.2812"	Z	.4130"				
65	.0350"	45	.0820"	26	.1470"	13/64	.2031"	L	.2900"	27/64	.4219"				
64	.0360"	44	.0860"	25	.1495"	6	.2040"	M	.2950"	7/16	.4375"				
63	.0370"	43	.0890"	24	.1520"	5	.2055"	19/64	.2968"	29/64	.4531"				
62	.0380"	42	.0935"	23	.1540"	4	.2090"	N	.3020"	15/32	.4687"				
61	.0390"	3/32	.0937"	5/32	.1562"	3	.2130"	5/16	.3125"	31/64	.4844"				
60	.0400"	41	.0960"	22	.1570"	7/32	.2187"	O	.3160"	1/2	.5000"				

Ref. 41

Hole size	Tolerance
0.0135 – 0.125	+ .004/- .001
0.1260 – 0.250	+ .005/- .001
0.2510 – 0.500	+ .006/- .001
0.5010 – 0.750	+ .008/- .001
0.7510 – 1.000	+ .010/- .001
1.001 – 2.000	+ .012/- .001

## Appendix 7A.1—Miscellaneous Design Data and Information: True-Position Dimensioning for Fastener Holes

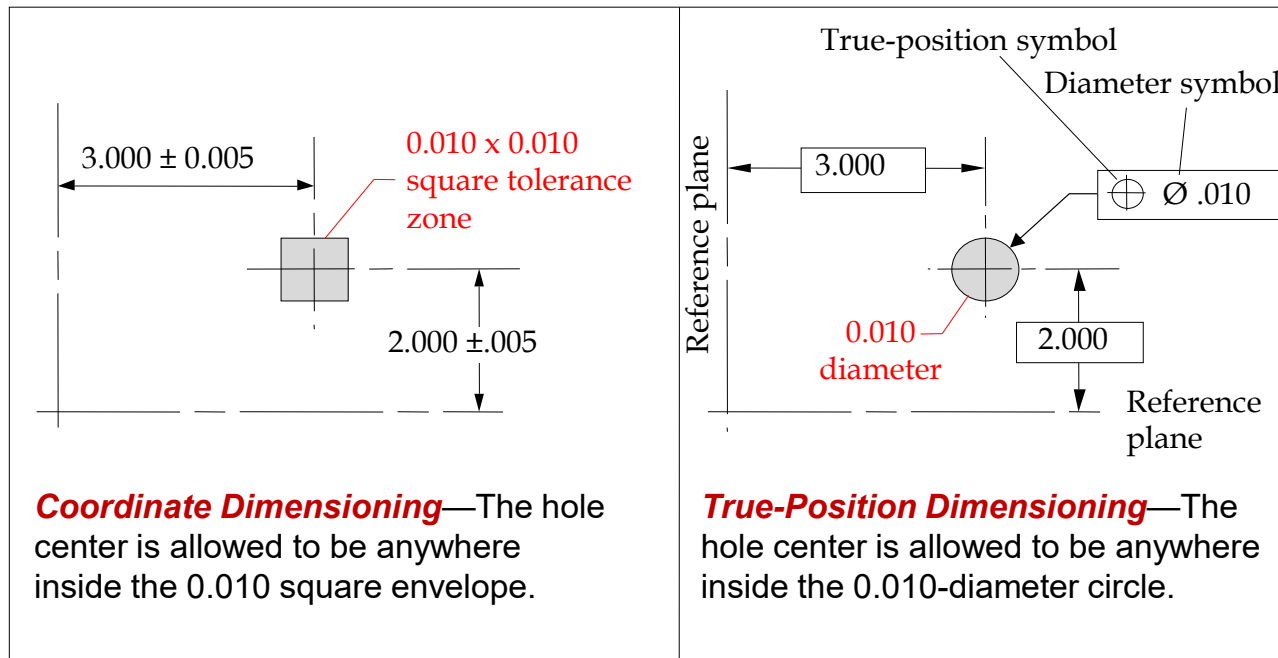

Ref. 16, Fig. 20.11

**For the same tolerance, true-position dimensioning (part of GD&T) allows a smaller radial error, hence less over-size on bolt holes.**

## Appendix 7A.1: Establishing Hole Sizes to Ensure Fit

### a. Floating Fasteners

Clearance holes in both parts

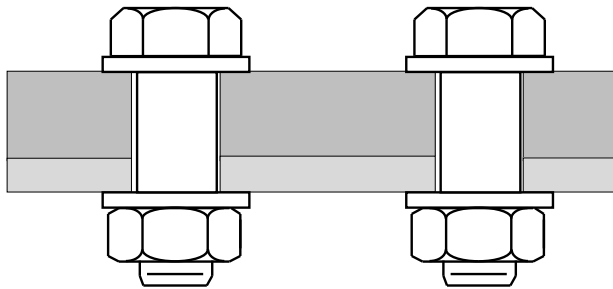

$$D_{h\text{-min}} = D_{b\text{-max}} + \tau$$

(both parts)

### b. Fixed Fasteners

Fixed in one part, floating in the other

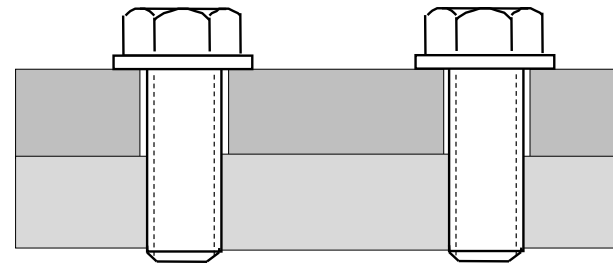

$$D_{h\text{-min}} = D_{b\text{-max}} + 2\tau$$

$D_{h\text{-min}}$  = Minimum diameter of clearance hole in floating part

$D_{b\text{-max}}$  = Maximum diameter of fastener

$\tau$  = True-position tolerance on hole location

Ref. 16, Fig. 20.12

## Appendix 7A.1: Recommended Fastener Hole Sizes for Metallic Parts

Multiple industry and company standards recommend hole clearance or size depending on application (e.g., NAS618, ref. 39).

My recommendations:

- Joints with multiple fasteners and low shear load (limit shear can be carried by friction per NASA-STD-5020B criteria):
  - To reduce manufacturing cost and ensure fit, drill parts separately with standard drill size, 0.020-0.040" larger than bolt diameter (less for #8s and smaller), e.g., 0.281 +0.006/-0.001 or 0.272 +0.006/-0.001 for ¼" bolts.
- Joints in single-mission spaceflight hardware that may slip under the limit shear load (limited number of slip cycles during ground testing and launch):
  - Match drill at assembly, if practical, with holes no larger than needed to ensure fit (e.g., 0.257 +0.006/-0.001 standard drill size for ¼" bolts).
  - If match drilling is not practical (e.g., high level of assembly in clean room), base hole size on the smallest true-positional tolerance that can be reasonably held (probably about 0.005"; check with your machine shop).
- Joints that may experience cyclic slip over long duration (e.g., aircraft):
  - Match drill and ream at assembly (e.g., 0.2495 to 0.2515 for ¼" bolts), and use bolts with close-tolerance diameter.
- To prevent slip, use an interference-fit shear pin or design to ensure friction carries the limit shear load. (Joint-slip analysis addressed in Sec. 9.)

Use  
floating  
fasteners  
rather  
than fixed  
fasteners

## Appendix 7A.1: Controlling Dimensions When Using Blind Fixed Holes with Heli-Coils®

All the following process steps must be controlled by the engineering drawing (or other such documentation) to ensure proper screw installation.

(See the Heli-Coil catalog for additional guidance, <http://www.helicoil.in/pdf/HeliCoil%20Catalogue.pdf>)

### 1. Drill hole and countersink

Minimum drill depth to be determined based on subsequent steps

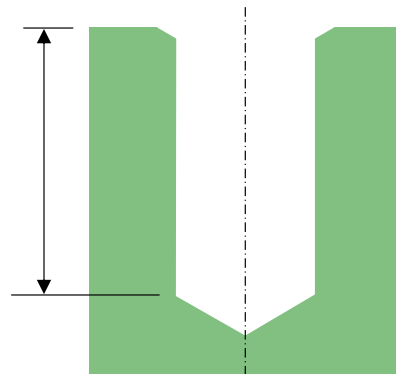

### 2. Tap the hole (cut threads)

Incomplete lead threads (number depends on the type of tap)

$\geq 1p$  nominal clearance for end of tap

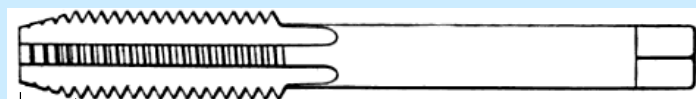
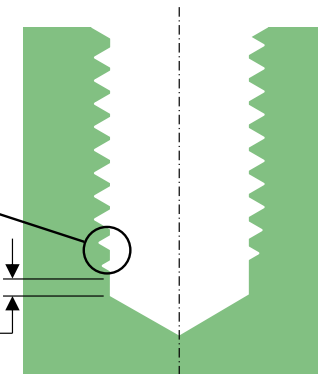

Plug tap

Typically 3 to 5p for taper and lead threads

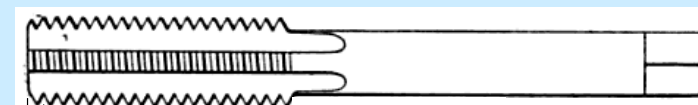

Bottoming tap

Typically 1 to 1.5p for lead threads

Images from Wikipedia

When needed in a blind hole, a bottoming tap is used to finish the threads near the bottom of the hole after threads are initially cut with a plug tap.

continued

## Appendix 7A.1: Controlling Dimensions when Using Blind Fixed Holes with Heli-Coils<sup>®</sup>, cont'd

### 4. Assemble parts, install screw

### 3. Check tapped holes with a gage, then install Heli-Coil

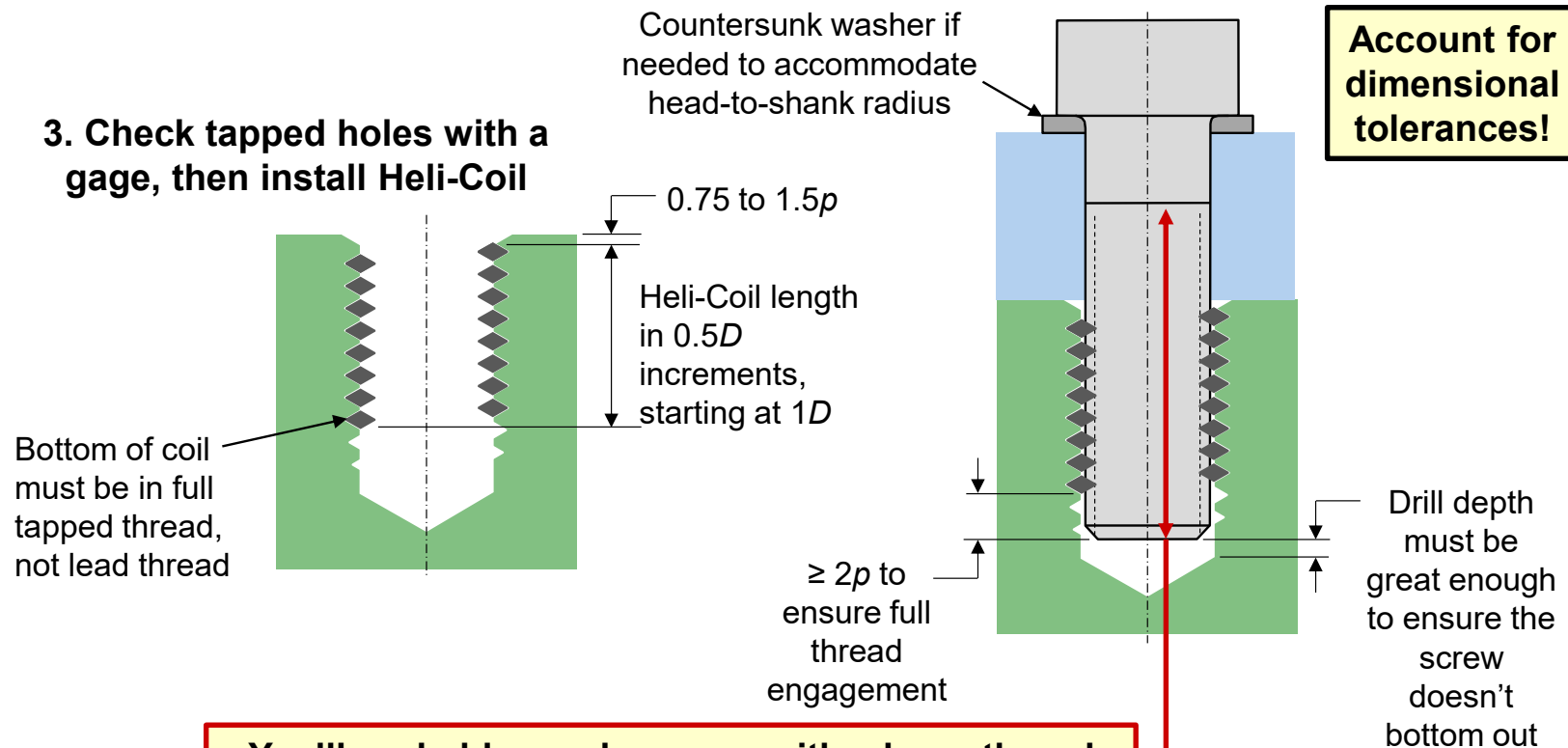

## Appendix 7A.2—Additional Torque-Preload Test Data: Titanium Galls Easily, So Use Proper Lubrication

Case history:

- #8 A-286 socket head cap screws (NAS1352) inserted into tapped titanium
- No washers; screw heads torqued against titanium
- Oil used for lubrication in the threads
- Application: cryocooler, with cyclic temperature and pressure
- A screw failed after 20 million cycles of compressor operation, causing pressure loss.
- Metallurgical tests showed the failure was fatigue. Preload had been inadequate.
- Fasteners had been torqued to 28 – 31 in-lb.
  - Using  $K = 0.2$ , predicted preload =  $29.5/[0.2(0.164)] = 900$  lb
- Subsequent torque-preload testing: Out of 6 screws tested (torqued to 28 – 31 in-lb),
  - Max preload = 550 lb ( $K_{\min} = 0.327$ )
  - Mean preload = 310 lb ( $K_{\text{nom}} = 0.580$ )
  - Min preload = 230 lb ( $K_{\max} = 0.783$ )

**Much less preload than predicted, and a lot of scatter!**

## Appendix 7A.2: Case History, continued

### Corrective action:

- Changed from #8 to #10 fastener size
- Designed a custom 15-5 PH steel washer
  - 16 finish
  - Surfaces parallel within 0.0005"
  - Small countersink to avoid interference with under-head radius
- Used moly-disulphide dry-film lubricant along with processed oil
  - Applied to washer, screw threads, underside of screw head, and surface of tapped hole

### Results (6 fasteners torqued to 48 – 53 in-lb):

- |                          |                           |  |
|--------------------------|---------------------------|--|
| – Max preload = 1500 lb  | $(K_{\min} = 0.18)$       |  |
| – Mean preload = 1300 lb | $(K_{\text{nom}} = 0.20)$ |  |
| – Min preload = 1030 lb  | $(K_{\max} = 0.26)$       |  |

**Much less scatter and  
in the range we expect  
for steel fasteners**

## Appendix 7A.2: Effect of Surface Roughness on Nut Factor, NAS1351 Screws in Tapped Aluminum without Lubrication

#4 (D = 0.112") A-286 NAS1351 screws installed in tapped 6061-T6 aluminum alloy, with NAS620C4L stainless washer, no lubrication and no locking feature. Torque was 10 in-lb

Approximate surface roughness	Preload, $P_{pi}$ (lb)	Nut factor, $K$	For this surface roughness only			For all surface roughness tested		
			Nominal initial preload, $P_{pi-nom}$	Nominal nut factor, $K_{nom}$	Variation, $\Gamma$	Nominal initial preload, $P_{pi-nom}$	Nominal nut factor, $K_{nom}$	Variation, $\Gamma$
< 32 $\mu$ in	376	0.24	360	0.25	0.04	275	0.33	0.37
	361	0.25			0.00			0.31
	357	0.25			-0.01			0.30
	340	0.26			-0.06			0.24
	337	0.26			-0.06			0.23
	390	0.23			0.08			0.42
63 $\mu$ in	255	0.35	232	0.39	0.10	275	0.33	-0.07
	244	0.37			0.05			-0.11
	225	0.40			-0.03			-0.18
	239	0.37			0.03			-0.13
	216	0.41			-0.07			-0.21
	212	0.42			-0.09			-0.23
125 $\mu$ in	205	0.44	232	0.39	-0.12	275	0.33	-0.25
	227	0.39			-0.02			-0.17
	214	0.42			-0.08			-0.22
	298	0.30			0.29			0.09
	220	0.41			-0.05			-0.20
	227	0.39			-0.02			-0.17

Test data courtesy MDA Space

The fasteners with high surface roughness had been grit blasted by the supplier.

$P_{pi-nom}$  is the sample mean preload (average test value).

$$K_{nom} = \frac{T}{DP_{pi-nom}}$$

For a given trial,

$$\Gamma = \frac{P_{pi}}{P_{pi-nom}} - 1$$

## Appendix 7A.2: Effect of Surface Roughness on Nut Factor, NAS1351 Screws in Heli-Coils without Lubrication

#4 (D = 0.112") A-286 NAS1351 screws installed in free-running stainless steel Heli-Coils in 6061-T6 aluminum alloy, with NAS620C4L stainless washer, no lubrication. Torque was 10 in-lb

Approximate surface roughness	Preload, $P_{pi}$ (lb)	Nut factor, $K$	For this surface roughness only			For all surface roughness tested		
			Nominal initial preload, $P_{pi-nom}$	Nominal nut factor, $K_{nom}$	Variation, $\Gamma$	Nominal initial preload, $P_{pi-nom}$	Nominal nut factor, $K_{nom}$	Variation, $\Gamma$
< 32 $\mu$ in	343	0.26	323	0.28	0.06	317	0.28	0.08
	314	0.28			-0.03			-0.01
	289	0.31			-0.10			-0.09
	318	0.28			-0.01			0.00
	358	0.25			0.11			0.13
	313	0.29			-0.03			-0.01
63 $\mu$ in	330	0.27	299	0.30	0.11	317	0.28	0.04
	302	0.30			0.01			-0.05
	258	0.35			-0.14			-0.19
	318	0.28			0.07			0.00
	293	0.30			-0.02			-0.08
	290	0.31			-0.03			-0.08
125 $\mu$ in	389	0.23	330	0.27	0.18	317	0.28	0.23
	408	0.22			0.24			0.29
	358	0.25			0.09			0.13
	313	0.29			-0.05			-0.01
	275	0.32			-0.17			-0.13
	235	0.38			-0.29			-0.26

Test data courtesy MDA Space

The fasteners with high surface roughness had been grit blasted by the supplier.

$P_{pi-nom}$  is the sample mean preload (average test value).

$$K_{nom} = \frac{T}{DP_{pi-nom}}$$

For a given trial,

$$\Gamma = \frac{P_{pi}}{P_{pi-nom}} - 1$$

## **8. Mechanics of a Preloaded Joint Under Applied Tension**

- How Bolt Load Changes with Applied Load
- Designing to Reduce Cyclic Load in the Bolt
- Estimating Bolt Stiffness and Clamp Stiffness
- Understanding the Load-Introduction Factor
- Example Problem 8-c: Worst Case for Steel Bolts and Aluminum Fittings
- A High Preload Typically Increases Fatigue Life
- Effects of Bolt Ductility
- How Temperature Change Affects Preload
- Appendix: Analysis for Example Problem 8-c

Permission is granted by Instar for anyone to freely copy, distribute, and print this material, but only in its unaltered form. This section may be separately copied or printed, but only in its entirety, including this page and with headers and footers intact. Unaltered individual figures and tables and portions of text may be copied or used, but only with text in quotes and with the following statement "Source: Design and Analysis of Bolted Joints (DABJ) course book, Thomas P. Sarafin, Instar Engineering and Consulting, Inc. Reproduced with permission." The date of last revision also should be included in the reference. If you have questions, contact [tom.sarafin@instarengineering.com](mailto:tom.sarafin@instarengineering.com).

## How Bolt Load Changes with Applied Tensile Load

Objective 1: Ensure the preload is high enough that the joint does not gap under service loads.

Objective 2 for most joints: Increase stiffness of joint members relative to that of the bolt in order to reduce cyclic stress in the bolt and preserve its fatigue life.

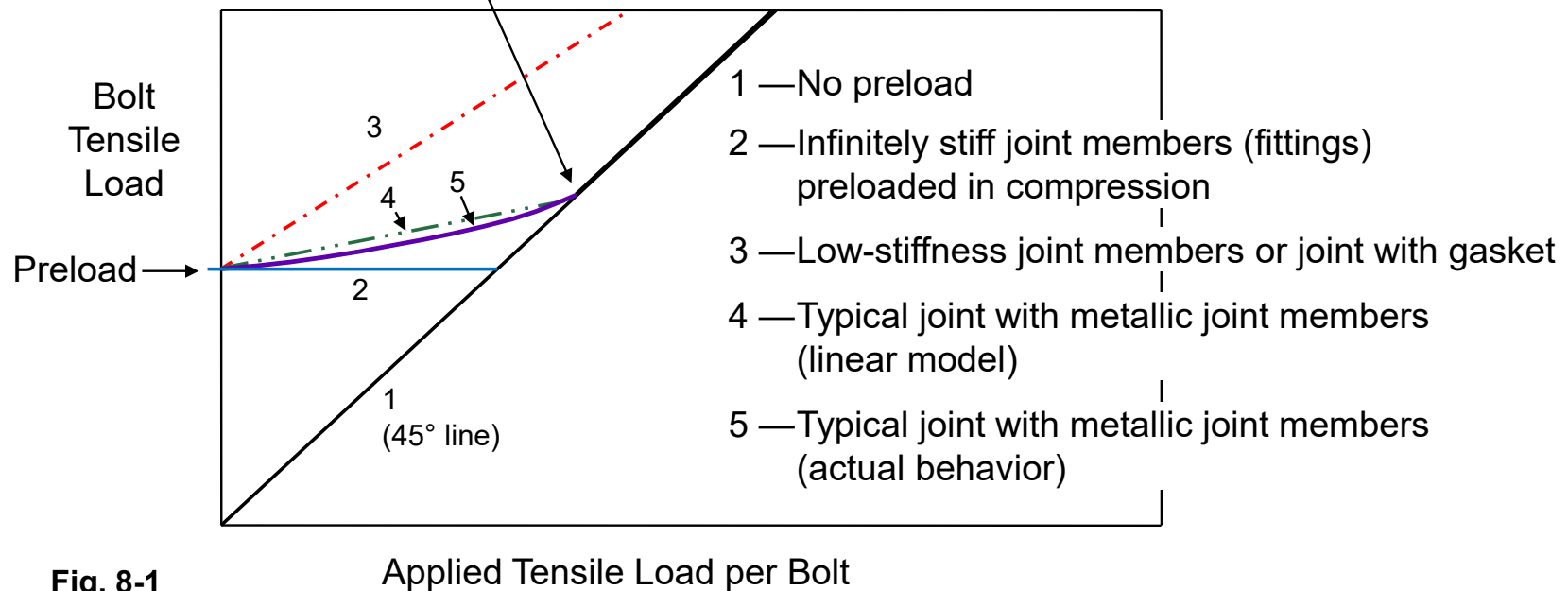

Fig. 8-1

## Designing to Reduce Cyclic Load in the Bolt

The percentage of applied load that goes into the bolt on top of preload depends on the stiffness associated with relieving compression in the joint members at the faying surface relative to that associated with increasing the bolt's tensile load.

We can reduce the amount that bolt load changes with applied load by increasing stiffness of the load path through the joint members.

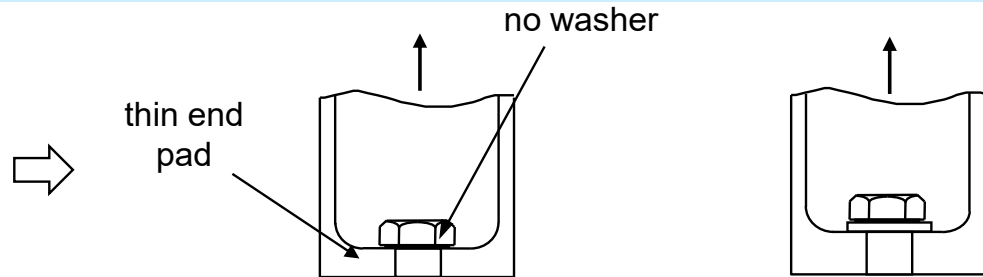

Fig. 8-2

This bolt will see a significant increase in load as tension is applied to the joint.

A better design; bolt load doesn't change much with applied load.

Or by reducing bolt stiffness.

- Fully threaded
- Reduced-shank bolt
- Neither option should be used for shear joints.



Fig. 8-3

## Estimating Bolt Load for a Preloaded Joint Under Applied Tension

With linear theory, up to an applied tensile load that either gaps the joint or ruptures the threaded fastening system, ...

The bolt's tensile load is  $P_{tb} = P_p + n\phi P_t$  (Eq. 8.1a) (NASA-STD-5020B Eq. 8)

Preload  $\rightarrow$   $P_p$   $\leftarrow$   $P_t =$  applied tensile load per bolt

where  $\phi$  is the **stiffness factor**:

$$\phi = \frac{k_b}{k_b + k_c}$$

Bolt stiffness  $\rightarrow$   $k_b$   $\leftarrow$  Stiffness of clamped joint members (referred to herein as **clamp stiffness**)

(Eq. 8.1b) (5020B Eq. 9)

and  $n$  is the **load-introduction factor** (a.k.a. **loading-plane factor**) a value between 0 and 1, used to adjust the calculated stiffness factor to agree better with how a real joint behaves (explanation provided in a later page).

## Example

- Preload = 6000 lb
- Applied tensile load = 10,000 lb
- $n\phi = 0.25$
- Total bolt load:

$$P_{tb} = 6000 + 0.25(10,000) = 8500 \text{ lb}$$

**Does this look right?**

## Class Quiz

A preloaded joint with a single bolt is subject to applied tensile load.

Is it possible for the total tensile load in the bolt to be less than the applied tensile load?

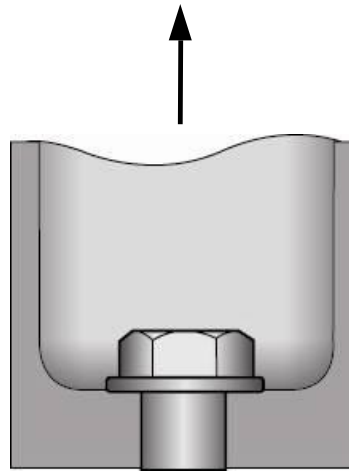

## The Answer to the Quiz Is Apparent from the Free-body Diagram

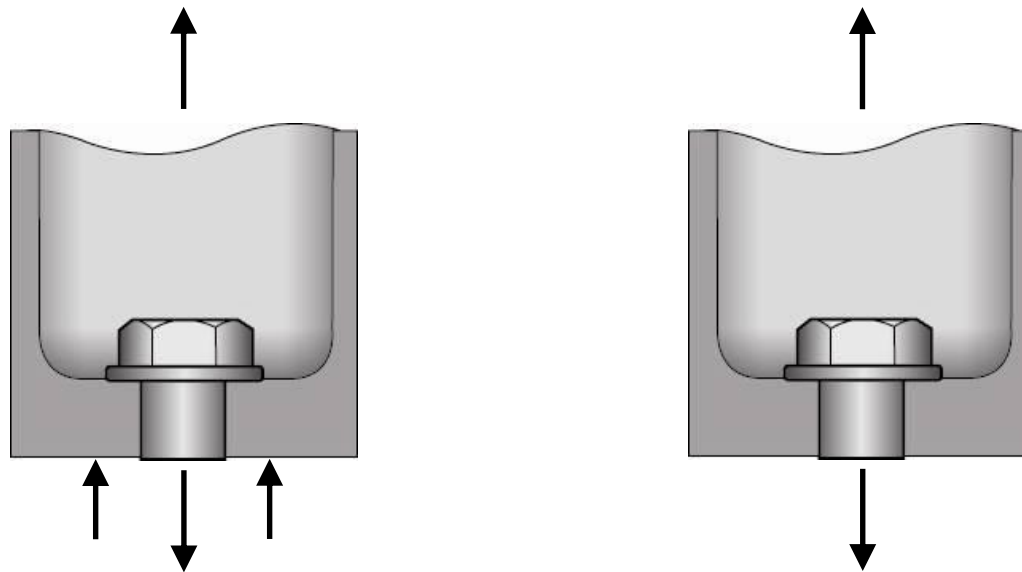

Fig. 8-4

Prior to separation:  
bolt load exceeds  
applied load

After separation:  
bolt load equals  
applied load

## Revisiting the Plot of Applied Load vs. Bolt Load

The linear model:

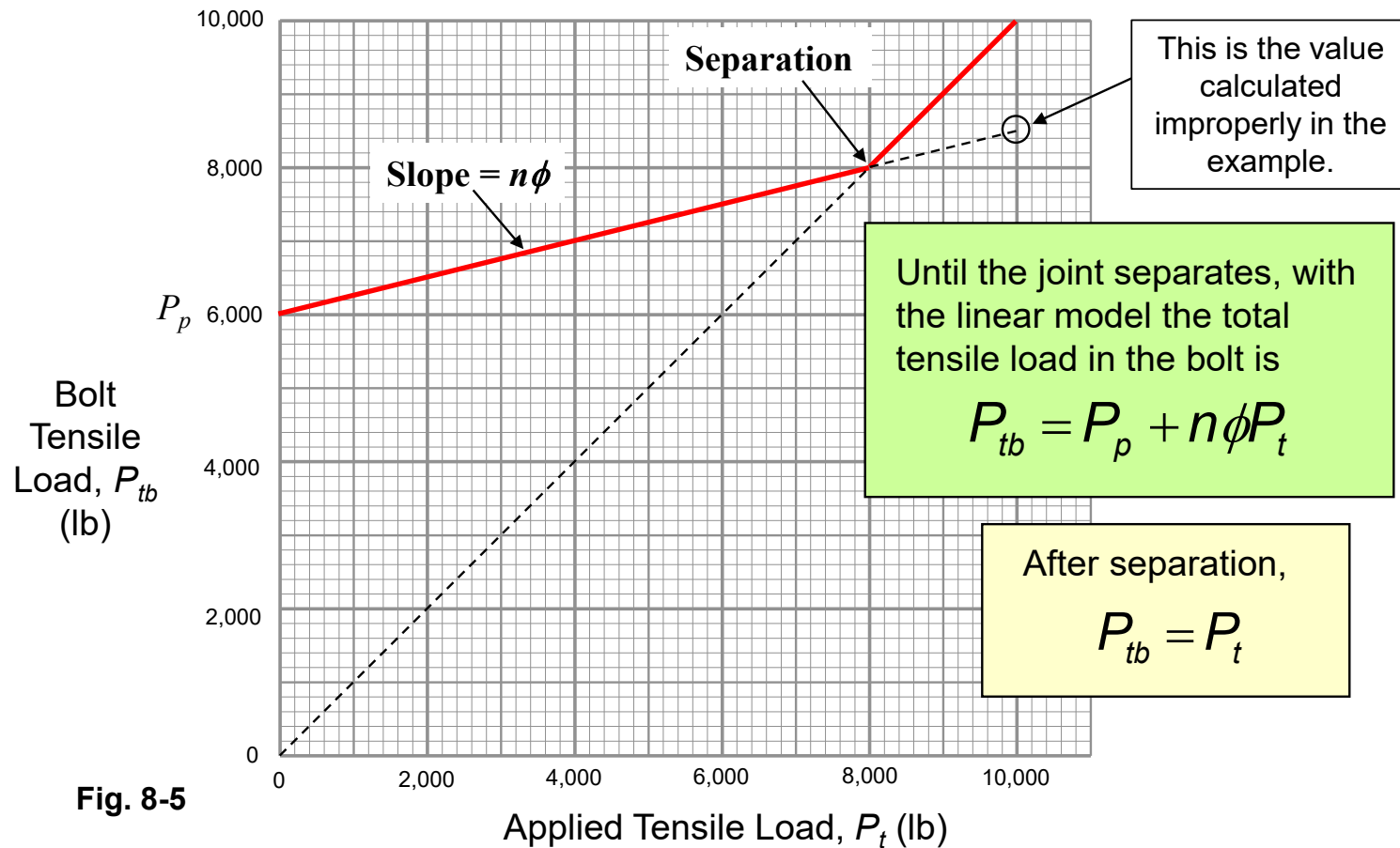

Fig. 8-5

## Joint Diagram Showing Load Sharing between Preloaded Bolt and Clamped Joint Members

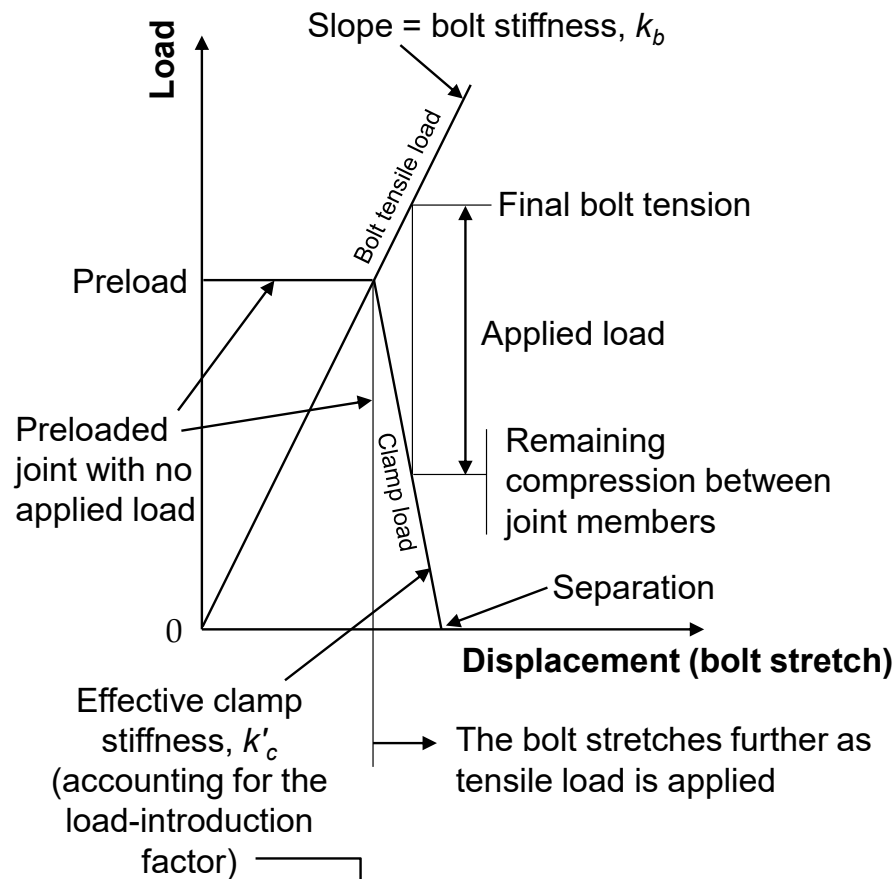

Fig. 8-6

See upcoming page

- As tensile load is applied, the bolt load increases and the clamp load decreases.
- Load sharing depends on the stiffness of the two load paths,  $k_b$  and  $k'_c$ .
- The applied load is equal to the difference between the tensile load in the bolt and the compressive load between joined parts.

The plot at left is based on linear theory, but we also can use a joint diagram with an actual load-displacement curve for a ductile bolt. (Example shown later in this section.)

## A Reasonable Method of Estimating Bolt Stiffness

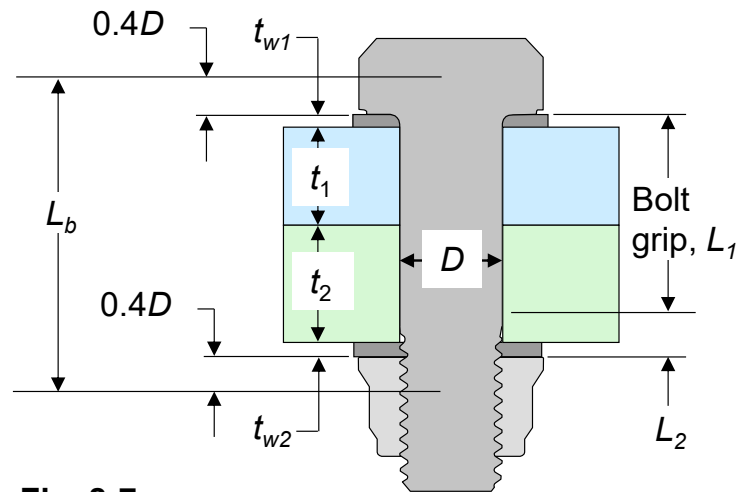

Fig. 8-7

A simpler form of Eq. 8.1c is

$$k_b = \frac{A_{\text{eff}} E_b}{L_b} \quad (\text{Eq. 8.1d})$$

where  $A_{\text{eff}}$  is an effective average cross-sectional area between  $A_s$  and  $A_t$ , depending on how much of the bolt length is threaded

For a through (floating) bolt:

$$k_b = E_b \left[ \frac{L_1 + 0.4D}{A_s} + \frac{L_2 + 0.4D}{A_t} \right]^{-1} \quad (\text{Eq. 8.1c})$$

$E_b$  = elastic modulus of bolt material

$D$  = basic diameter

$A_s$  = cross-sectional area of full-diameter ( $D$ ) body

$A_t$  = tensile stress area

(Modified from Ref. 34 (Unbrako Engineering Guide) for simplification to use tensile stress area rather than minor-diameter area and basic diameter,  $D$ , rather than minor diameter; the difference is minor)

## Estimating Clamp Stiffness

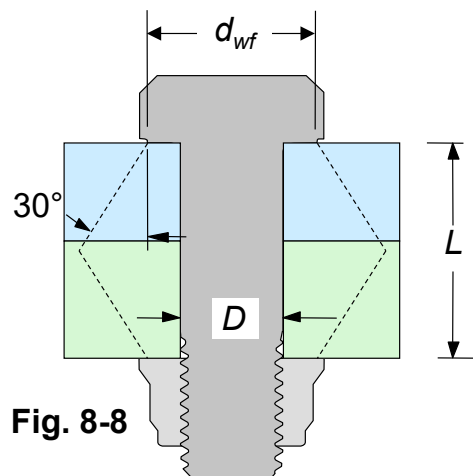

Fig. 8-8

For use in Eq. 8.1b, clamp stiffness,  $k_c$ , is commonly assumed to be equal to the stiffness of two back-to-back 30° frustums\* (partial cones) projecting from the bolt head and the nut.

Let's look first at the case in which there are no washers, and the diameter of the nut's contact surface is the same as the diameter of the bolt head's washer face,  $d_{wf}$ .

If all clamped materials have the same elastic modulus\*\* and the edge of the parts don't clip off the extremities of the assumed frustums, the clamp stiffness is calculated as\*

$$k_c = \frac{1.81E_c D}{2 \ln \left\{ \frac{(0.577L + d_{wf} - D)(d_{wf} + D)}{(0.577L + d_{wf} + D)(d_{wf} - D)} \right\}} \quad (\text{Eq. 8.1e})$$

Natural log

$E_c$  = compressive elastic modulus

Equation 8.1e actually should use bolt-hole diameter rather than bolt diameter,  $D$ . The difference is usually small relative to the uncertainty in the frustum idealization.

\*Ref 4, Shigley and Mischke, *Mechanical Engineering Design*, 5<sup>th</sup> ed. Use of a 30° angle is generally considered to be conservative for assessing the bolt, which means it can be unconservative for gapping analysis and joint-slip analysis.

\*\*See appendix to this section for an example of how to divide the frustums into thinner frustum slices, which can be used to account for different materials.

## Example Problem 8-a: Estimating $k_c$ when Joint Members' Geometry Does Not Fully Capture the Assumed Frustums

Two joined parts with cylindrical cross sections

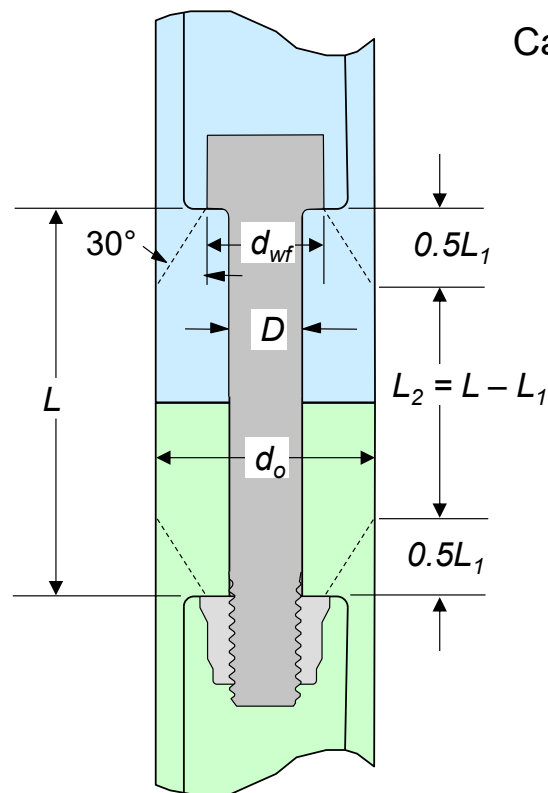

Calculate clamp stiffness as  $k_c = \left[ \frac{1}{k_{c1}} + \frac{1}{k_{c2}} \right]^{-1}$

where

$$k_{c1} = \frac{1.81E_c D}{2 \ln \left\{ \frac{(0.577L_1 + d_{wf} - D)(d_{wf} + D)}{(0.577L_1 + d_{wf} + D)(d_{wf} - D)} \right\}}$$

$$k_{c2} = \frac{\pi(d_o^2 - D^2)}{4} \left( \frac{E_c}{L_2} \right)$$

Fig. 8-9

## Estimating Clamp Stiffness (continued)

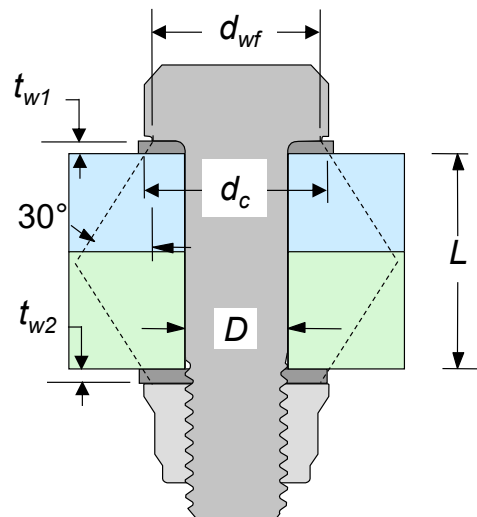

Fig. 8-10

$E_c$  = elastic modulus of material used for joint members

If we add washers, the bolt becomes longer, thus less stiff, and more volume of assumed clamped material is involved, increasing the clamp stiffness.

The 30° compression zone in the fittings (joint members) has a starting diameter  $d_c$  calculated as

$d_c$  = lesser of ...

$$d_{wf} + 2t_w \tan 30^\circ = d_{wf} + 1.155t_w$$

washer outer diameter (O.D.)

$t_w$  = average thickness of the two washers

If all clamped materials between washers have the same elastic modulus, the clamp stiffness is calculated as

$$k_c = \frac{1.81E_c D}{2 \ln \left\{ \frac{(0.577L + d_c - D)(d_c + D)}{(0.577L + d_c + D)(d_c - D)} \right\}} \quad \text{(Eq. 8.1f)}$$

(see note for Eq. 8.1e)

We've ignored the flexibility of the washers in the above calculation, based on the assumption they are very stiff. If we elect to account for washer stiffness as another spring in the system, should we use it to reduce  $k_b$  or  $k_c$ ?

## Load Path Into a Bolt for Tensile Loading

Even though the washer is in compression, its flexibility reduces the stiffness of the bolt load path because, for any portion of applied load to go through the bolt, it first must go through the washer.

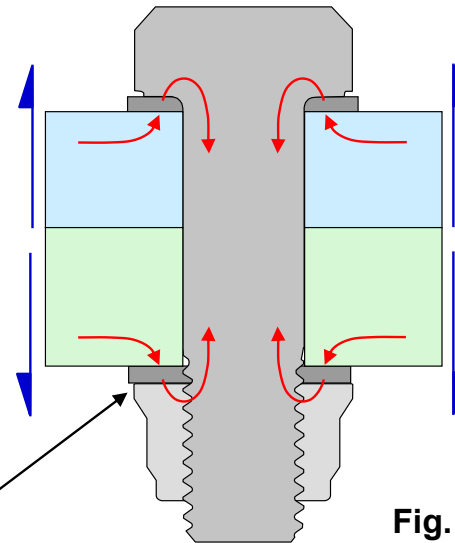

Fig. 8-11

If the washers have low stiffness (“soft” springs), as is the case for Belleville washers, the load in a preloaded bolt would change very little when tensile load is applied to the joint (assuming no gapping).

**When calculating bolt load caused by applied tensile load, it’s conservative to ignore washer stiffness.**

## Understanding the Load-Introduction Factor

Same as with the washer, load must further compress the material just under the washer in order to go through the washer and into the bolt.

The methods described in earlier pages herein for calculating bolt stiffness and clamp stiffness are based on an incorrect idealization.

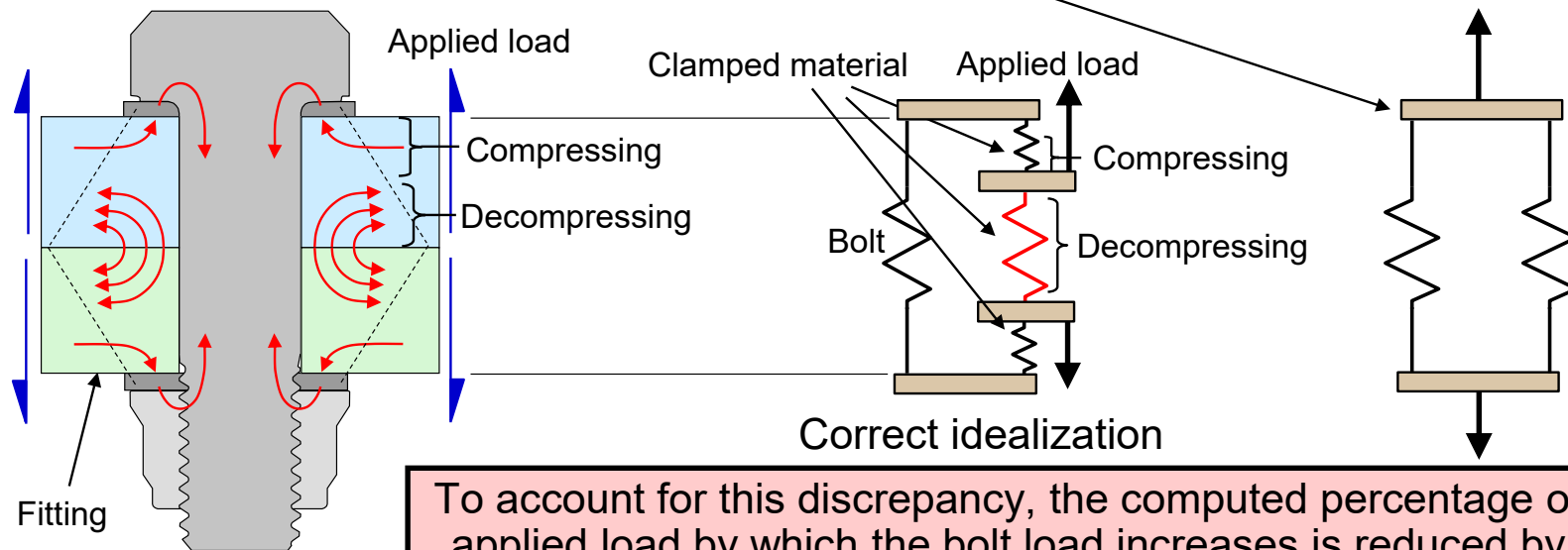
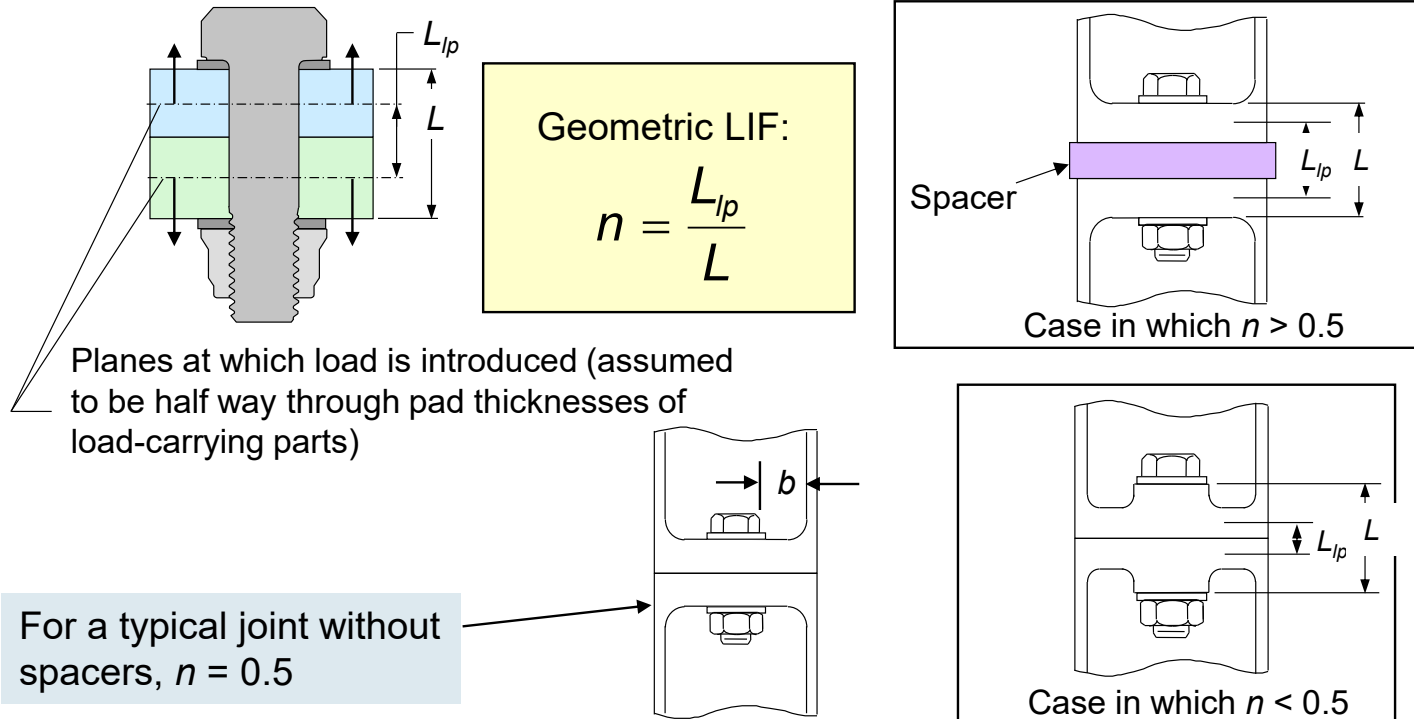

Fig. 8-12

To account for this discrepancy, the computed percentage of applied load by which the bolt load increases is reduced by the **load-introduction factor,  $n$** , per Eq. 8.1a.

**Without use of this factor, we would over-predict both the total bolt load (conservative) and the separation load (unconservative).**

## Geometric Load-Introduction Factor (LIF) (modified version of NASA-STD-5020B Fig. 3)



Note: Dimension  $b$  affects the nonlinearity of  $n$ . It's conservative to ignore this effect for bolt analysis.

Use of the geometric LIF, as defined above, is a simple approximation that generally over-predicts bolt load under tension loading in a preloaded joint that has not gapped. If more accuracy is needed, make a detailed finite element model or calculate the stiffness-based LIF. (See Ref. 52.)

## Modifying the Joint Diagram for the Load-Introduction Factor

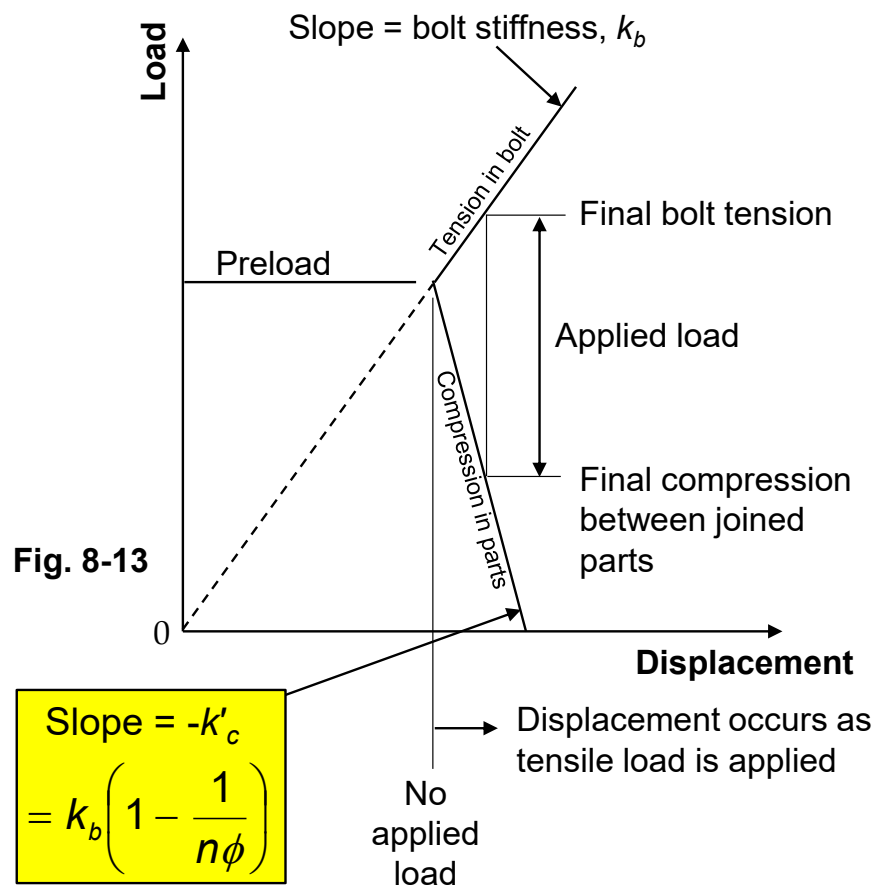

From Eq. 8.1a, a preloaded bolt's tensile load increases by percentage  $n\phi$  of the applied load, where

$$\phi = \frac{k_b}{k_b + k_c}$$

The **effective clamp stiffness,  $k'_c$** , which accounts for the effects of  $n$  for use in the joint diagram, satisfies the following equation:

$$\frac{k_b}{k_b + k'_c} = \frac{nk_b}{k_b + k_c}$$

Solving for  $k'_c$  yields  $k'_c = k_b \left( \frac{1}{n\phi} - 1 \right)$   
**(Eq. 8.2)**

## Example Problem 8-b: Estimating Bolt Load for a Preloaded Joint under Applied Tensile Load

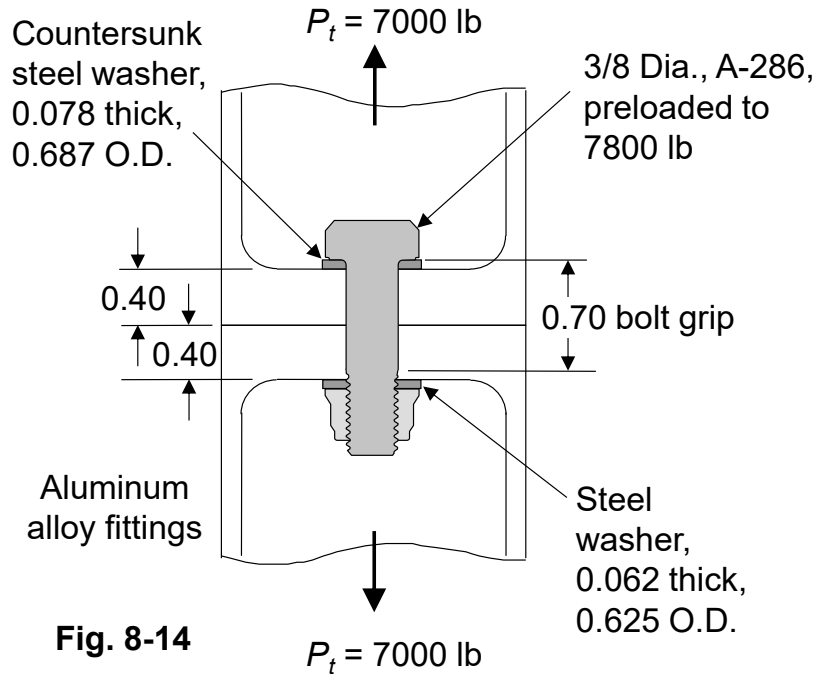

Fig. 8-14

Given:

$$D = 0.375 \text{ in}$$

$$A_t = 0.0878 \text{ in}^2$$

$$d_{wf} = 0.523 \text{ in}$$

$$A_s = \frac{\pi D^2}{4} = 0.1104 \text{ in}^2$$

$$E_b = 29 \times 10^6 \text{ psi}$$

$$E_c = 10 \times 10^6 \text{ psi}$$

Using Eqs. 8.1, calculate

1. bolt stiffness
2. clamp stiffness
3. bolt load

## Example Problem 8-b, continued

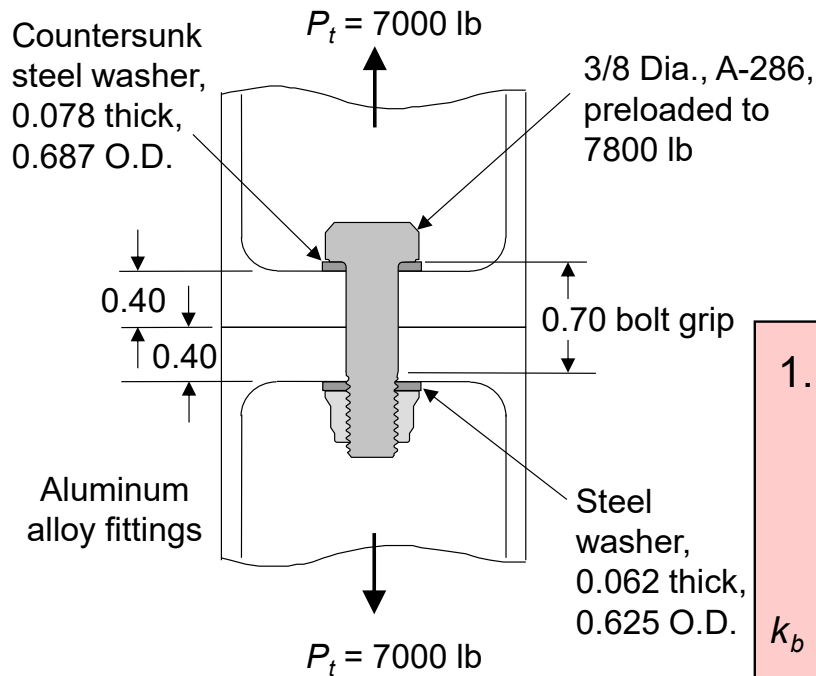

Repeat of Fig. 8-14

Given:

$$D = 0.375 \text{ in}$$

$$A_t = 0.0878 \text{ in}^2$$

$$d_{wf} = 0.523 \text{ in}$$

$$A_s = \frac{\pi D^2}{4} = 0.1104 \text{ in}^2$$

$$E_b = 29 \times 10^6 \text{ psi}$$

$$E_c = 10 \times 10^6 \text{ psi}$$

### 1. Bolt stiffness (Eq. 8.1c)

$$L_1 = 0.70 \text{ in}$$

$$L_2 = 0.40 + 0.40 + 0.078 + 0.062 - 0.70 = 0.240 \text{ in}$$

$$k_b = 29 \times 10^6 \left[ \frac{0.70 + 0.4(0.375)}{0.1104} + \frac{0.240 + 0.4(0.375)}{0.0878} \right]^{-1}$$

$$= 2.39 \times 10^6 \text{ lb/in}$$

(continued)

## Example Problem 8-b, continued

2. Clamp stiffness (Eq. 8.1f):

$$\text{Average washer thickness, } t_w = \frac{0.078 + 0.062}{2} = 0.070 \text{ in}$$

Initial diameter of fitting compression zone,

$$d_c = \text{lesser of ...}$$

$$d_{wf} + 1.155t_w = 0.523 + 1.155(0.070) = 0.604 \text{ in} \quad \leftarrow$$

washer O.D. = 0.625 in (smaller of the two washers)

$$k_c = \frac{1.81(10 \times 10^6)(0.375)}{2 \ln \left\{ \frac{[0.577(0.80) + 0.604 - 0.375](0.604 + 0.375)}{[0.577(0.80) + 0.604 + 0.375](0.604 - 0.375)} \right\}}$$
$$= 4.73 \times 10^6 \text{ lb/in}$$

(continued)

## Example Problem 8-b, conclusion

3. Bolt load (Eqs. 8.1a and b):

$$\text{Stiffness factor, } \phi = \frac{2.39 \times 10^6}{(2.39 + 4.73) \times 10^6} = 0.336$$

Load-introduction factor,  $n = 0.5$

The applied load does not exceed the preload, so we know the joint doesn't gap.

Bolt load,

$$P_{tb} = 7800 + 0.5(0.336)(7000) = 8980 \text{ lb}$$

The above is a linear analysis that ...

- over predicts the bolt load if the stress in the bolt exceeds the proportional limit of the bolt material
- and under predicts the bolt load if the joint gaps under the applied load.

## Estimating Stiffness of a Bolt in a Tapped Hole or a Threaded Insert

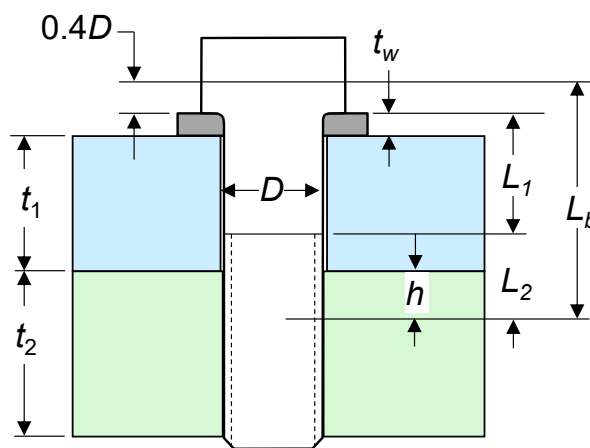

Bolt stiffness:

$$k_b = E_b \left[ \frac{L_1 + 0.4D}{A_s} + \frac{L_2}{A_t} \right]^{-1} \quad (\text{Eq. 8.1g})$$

$h$  = the lesser of  $D/2$  and  $t_2/2$  (ref. 4, Shigley and Mischke) (usually,  $h = D/2$ )

Fig. 8-15

Equation 8.1d applies here as well:

$$k_b = \frac{A_{\text{eff}} E_b}{L_b}$$

where  $A_{\text{eff}}$  is an effective average cross-sectional area between  $A_s$  and  $A_t$ , depending on how much of the bolt length is threaded

## Estimating Clamp Stiffness for Bolts in Tapped Holes or Inserts

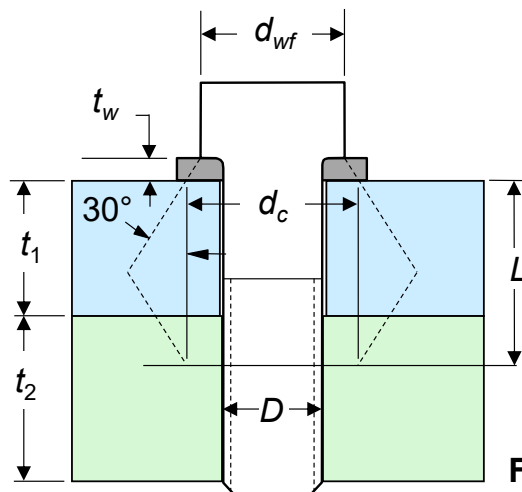

Fig. 8-16

For a screw going into a tapped hole or a threaded insert, available references offer conflicting methods of calculating clamp stiffness,  $k_c$ . A reasonable approach, which is conservative for assessing the bolt, is the one in Ref. 4 (Shigley and Mischke), Fig. 8-18. A modified version to account for the projection through the washer is shown in the figure at left.

$$\text{Assuming } D < t_2, \quad L = t_1 + \frac{D}{2}$$

If the following statements are true, use Eq. 8.1f with the above value for  $L$  to compute  $k_c$ :

- The clamped materials for both (or all) fittings have the same elastic modulus.
- The clamped joint members provide enough edge distance to fully capture the assumed frustums. (If not, make a conservative assumption.)



**Table 8-1. Stiffness Comparison for Steel Bolts with Aluminum Joint Members (through bolts, no washers), Load-Introduction Factor = 0.5**

Assumptions:		Steel or A286 bolt, fine threads	$E_b =$	29000000	psi	Based on Equations 8.1							
		Aluminum joint members	$E_c =$	10000000	psi								
		No washers											
		Through bolts with nuts	Total thickness of joint members (L in Fig. 8-8) varied between 4D and 1.5D										
		Edge distances sufficient to fully capture the assumed compression frustums											
Bolt	Basic major dia, $D$	Full body area, $A_b$	Tensile-stress area, $A_t$	Assumed effective area, $A_{eff}$	Bolt-head or washer-face dia, $d_{wf}$	Average washer thickness, $t_w$	Initial dia. of compress. area, $d_c$	Total clamp thickness, $L$ (in)	Effective bolt length, $L_b$	Bolt stiffness, $K_b$	Clamp stiffness, $K_c$	Joint-stiffness factor, $\phi$	$n\phi$
NAS 1351 (#4)	0.112	0.0099	0.0066	0.0089	0.180	0.000	0.180	0.448	0.538	478825	1084245	0.31	15%
	0.112	0.0099	0.0066	0.0089	0.180	0.000	0.180	0.168	0.258	999287	1691056	0.37	19%
NAS 1351 (#6)	0.138	0.0150	0.0101	0.0135	0.222	0.000	0.222	0.552	0.662	591557	1338439	0.31	15%
	0.138	0.0150	0.0101	0.0135	0.222	0.000	0.222	0.207	0.317	1234554	2088333	0.37	19%
NAS 1351 (#8)	0.164	0.0211	0.0147	0.0192	0.266	0.000	0.266	0.656	0.787	707533	1615950	0.30	15%
	0.164	0.0211	0.0147	0.0192	0.266	0.000	0.266	0.246	0.377	1476590	2529720	0.37	18%
NAS 1351 (#10)	0.190	0.0284	0.0200	0.0258	0.308	0.000	0.308	0.760	0.912	821890	1870144	0.31	15%
	0.190	0.0284	0.0200	0.0258	0.308	0.000	0.308	0.285	0.437	1715248	2926999	0.37	18%
NAS 1954	0.250	0.0491	0.0404	0.0465	0.398	0.000	0.398	1.000	1.163	1158832	2376191	0.33	16%
	0.250	0.0491	0.0404	0.0465	0.398	0.000	0.398	0.375	0.538	2504559	3691736	0.40	20%
NAS 1955	0.313	0.0767	0.0640	0.0729	0.460	0.000	0.460	1.250	1.456	1451380	2539135	0.36	18%
	0.313	0.0767	0.0640	0.0729	0.460	0.000	0.460	0.469	0.675	3130846	3814656	0.45	23%
NAS 1956	0.375	0.1104	0.0951	0.1058	0.523	0.000	0.523	1.500	1.757	1747175	2717028	0.39	20%
	0.375	0.1104	0.0951	0.1058	0.523	0.000	0.523	0.563	0.819	3746413	3981296	0.48	24%
NAS 1957	0.438	0.1503	0.1288	0.1439	0.648	0.000	0.648	1.750	2.048	2036839	3600436	0.36	18%
	0.438	0.1503	0.1288	0.1439	0.648	0.000	0.648	0.657	0.955	4367031	5420786	0.45	22%
NAS 1958	0.500	0.1963	0.1717	0.1890	0.710	0.000	0.710	2.000	2.348	2333767	3766644	0.38	19%
	0.500	0.1963	0.1717	0.1890	0.710	0.000	0.710	0.750	1.098	4990606	5566511	0.47	24%

Bolt load increases by this percentage of applied load up to gapping, based on linear theory

**Table 8-2. Stiffness Comparison for Steel Bolts with Aluminum Joint Members (through bolts, washers under head and nut), Load-Introduction Factor = 0.5**

Assumptions:		Steel or A286 bolt, fine threads	$E_b =$	29000000	psi	Based on Equations 8.1							
		Aluminum joint members	$E_c =$	10000000	psi								
		Two washers:	#4 through #8: two plain washers ( $t = 0.032$ )										
			#10 through 1/2": countersunk ( $t = 0.078$ ) under head and plain ( $t = 0.063$ ) under nut										
		Through bolts with nuts	Total thickness of joint members ( $L$ in Fig. 8-10) varied between $4D$ and $1.5D$										
		Edge distances sufficient to fully capture the assumed compression frustums											
Bolt	Basic major dia, $D$	Full body area, $A_b$	Tensile-stress area, $A_t$	Assumed effective area, $A_{eff}$	Bolt-head or washer-face dia, $d_{wf}$	Average washer thickness, $t_w$	Initial dia. of compress. area, $d_c$	Total clamp thickness, $L$ (in)	Effective bolt length, $L_b$	Bolt stiffness, $K_b$	Clamp stiffness, $K_c$	Joint-stiffness factor, $\phi$	$n\phi$
NAS 1351 (#4)	0.112	0.0099	0.0066	0.0089	0.180	0.032	0.217	0.448	0.602	427886	1530624	0.22	11%
	0.112	0.0099	0.0066	0.0089	0.180	0.032	0.217	0.168	0.322	800424	2560150	0.24	12%
NAS 1351 (#6)	0.138	0.0150	0.0101	0.0135	0.222	0.032	0.259	0.552	0.726	539438	1781597	0.23	12%
	0.138	0.0150	0.0101	0.0135	0.222	0.032	0.259	0.207	0.381	1027393	2946937	0.26	13%
NAS 1351 (#8)	0.164	0.0211	0.0147	0.0192	0.266	0.032	0.303	0.656	0.851	654335	2058193	0.24	12%
	0.164	0.0211	0.0147	0.0192	0.266	0.032	0.303	0.246	0.441	1262397	3385446	0.27	14%
NAS 1351 (#10)	0.190	0.0284	0.0200	0.0258	0.308	0.071	0.390	0.760	1.054	711161	2876648	0.20	10%
	0.190	0.0284	0.0200	0.0258	0.308	0.071	0.390	0.285	0.579	1294583	4906716	0.21	10%
NAS 1954	0.250	0.0491	0.0404	0.0465	0.398	0.071	0.479	1.000	1.341	1005186	3355653	0.23	12%
	0.250	0.0491	0.0404	0.0465	0.398	0.071	0.479	0.375	0.716	1882617	5593115	0.25	13%
NAS 1955	0.313	0.0767	0.0640	0.0729	0.460	0.071	0.541	1.250	1.641	1288111	3487351	0.27	13%
	0.313	0.0767	0.0640	0.0729	0.460	0.071	0.541	0.469	0.860	2458611	5602030	0.31	15%
NAS 1956	0.375	0.1104	0.0951	0.1058	0.523	0.071	0.604	1.500	1.941	1581369	3650649	0.30	15%
	0.375	0.1104	0.0951	0.1058	0.523	0.071	0.604	0.563	1.004	3058731	5700489	0.35	17%
NAS 1957	0.438	0.1503	0.1288	0.1439	0.648	0.071	0.729	1.750	2.241	1861786	4543286	0.29	15%
	0.438	0.1503	0.1288	0.1439	0.648	0.071	0.729	0.657	1.148	3634374	7186048	0.34	17%
NAS 1958	0.500	0.1963	0.1717	0.1890	0.710	0.071	0.791	2.000	2.541	2156508	4699358	0.31	16%
	0.500	0.1963	0.1717	0.1890	0.710	0.071	0.791	0.750	1.291	4244528	7283780	0.37	18%

Bolt load increases by this percentage of applied load up to gapping, based on linear theory

**Table 8-3. Stiffness Comparison for Steel Bolts with Aluminum Joint Members (tapped hole or insert, washer under bolt head), Load-Introduction Factor = 0.5**

Assumptions:		Steel or A286 bolt, fine threads	$E_b =$	29000000	psi	Based on Equations 8.1							
		Aluminum joint members	$E_c =$	10000000	psi								
		Countersunk washer ( $t = 0.078$ ) under head for #10 through 1/2"											
		Plain washer ( $t = 0.032$ ) under head for #4 through #8											
		Fixed fasteners into threaded inserts						Thickness of joint member with through hole ( $t_1$ in Fig. 8-15) varied from $2D$ to $1D$					
		Edge distances sufficient to fully capture the assumed compression frustums											
Bolt	Basic major dia, $D$	Full body area, $A_b$	Tensile-stress area, $A_t$	Assumed effective area, $A_{eff}$	Bolt-head or washer-face dia, $d_{wf}$	Washer thickness, $t_w$	Initial dia. of compress. area, $d_c$	Thickness of part with through hole, $t_1$	Effective bolt length, $L_b$	Bolt stiffness, $K_b$	Clamp stiffness, $K_c$	Joint-stiffness factor, $\phi$	$n\phi$
NAS 1351 (#4)	0.112	0.0099	0.0066	0.0089	0.180	0.032	0.217	0.224	0.357	721458	1904046	0.27	14%
	0.112	0.0099	0.0066	0.0089	0.180	0.032	0.217	0.112	0.245	1051537	2560150	0.29	15%
NAS 1351 (#6)	0.138	0.0150	0.0101	0.0135	0.222	0.032	0.259	0.276	0.432	906635	2204620	0.29	15%
	0.138	0.0150	0.0101	0.0135	0.222	0.032	0.259	0.138	0.294	1331909	2946937	0.31	16%
NAS 1351 (#8)	0.164	0.0211	0.0147	0.0192	0.266	0.032	0.303	0.328	0.508	1097261	2540197	0.30	15%
	0.164	0.0211	0.0147	0.0192	0.266	0.032	0.303	0.164	0.344	1620983	3385446	0.32	16%
NAS 1351 (#10)	0.190	0.0284	0.0200	0.0258	0.308	0.078	0.398	0.380	0.629	1191675	3756425	0.24	12%
	0.190	0.0284	0.0200	0.0258	0.308	0.078	0.398	0.190	0.439	1707434	5120717	0.25	13%
NAS 1954	0.250	0.0491	0.0404	0.0447	0.398	0.078	0.488	0.500	0.803	1615899	4315227	0.27	14%
	0.250	0.0491	0.0404	0.0447	0.398	0.078	0.488	0.250	0.553	2346414	5810416	0.29	14%
NAS 1955	0.313	0.0767	0.0640	0.0703	0.460	0.078	0.550	0.625	0.984	2072782	4395808	0.32	16%
	0.313	0.0767	0.0640	0.0703	0.460	0.078	0.550	0.313	0.672	3037047	5803497	0.34	17%
NAS 1956	0.375	0.1104	0.0951	0.1028	0.523	0.078	0.613	0.750	1.166	2557208	4532347	0.36	18%
	0.375	0.1104	0.0951	0.1028	0.523	0.078	0.613	0.375	0.791	3770305	5892111	0.39	20%
NAS 1957	0.438	0.1503	0.1288	0.1396	0.648	0.078	0.738	0.875	1.347	3005299	5643967	0.35	17%
	0.438	0.1503	0.1288	0.1396	0.648	0.078	0.738	0.438	0.910	4448900	7383381	0.38	19%
NAS 1958	0.500	0.1963	0.1717	0.1840	0.710	0.078	0.800	1.000	1.528	3492617	5775653	0.38	19%
	0.500	0.1963	0.1717	0.1840	0.710	0.078	0.800	0.500	1.028	5191360	7472956	0.41	20%

Bolt load increases by this percentage of applied load up to gapping, based on linear theory

## Summary of Tables 8-1 through 8-3

- Given:
- Steel or A-286 bolts, #4 through ½” diameter, aluminum joint members
  - At least one washer under bolt head and, for bolt-nut assemblies, at least one washer under nut
  - 0.5 load-introduction factor (commonly assumed for most joints without spacers)
  - For bolt-nut assemblies: total thickness of joint members between 1.5 and 4.0 times bolt diameter
  - For bolt-insert assemblies: joint member with through hole has thickness between 1.0 and 2.0 times bolt diameter
  - Edge distance for clamped parts is great enough to fully capture the assumed 30° frustums

The methods presented herein for computing how applied tensile load distributes in a preloaded joint results in the following conclusion:

**For joints fitting the above description, up until gapping the bolt load will increase by no more than 20% of the applied tensile load.**

## Example Problem 8-c: Estimating $n\phi$ for a Joint with Steel or A-286 Bolts and Aluminum Joint Members (extreme case)

This is the type of joint for which the load-introduction factor is highest:  $n = \frac{L - t_e}{L}$

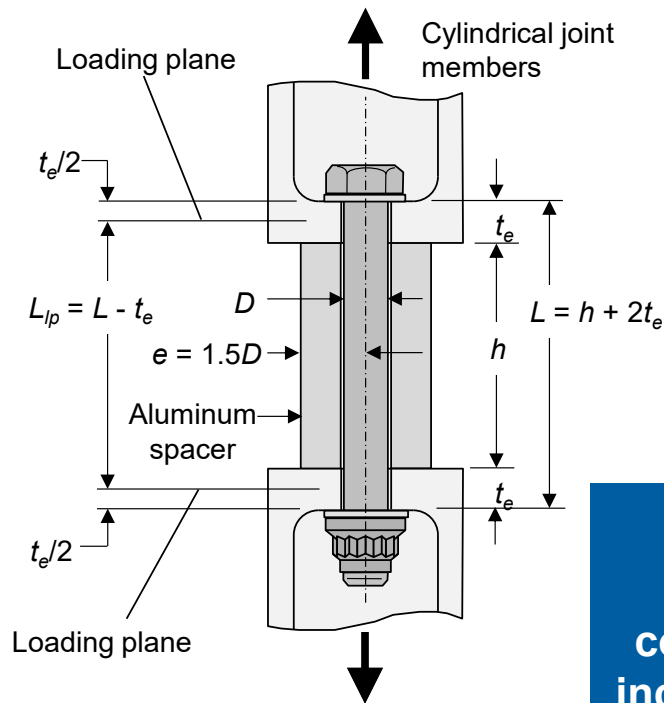

Fig. 8-17a

**For a preloaded joint, prior to separation, determine an upper bound for  $n\phi$ , the percentage of applied load by which the bolt load increases, given the following:**

- Steel bolt
- Aluminum fittings (joint members) and aluminum spacer, with typical clearance holes
- $e/D \geq 1.5$  for all clamped parts other than washers
- Load-introduction factor,  $n \leq 0.9$

### Conclusion:

**For a preloaded joint meeting the above constraints, prior to separation the bolt load will increase by no more than 25% of the applied load.**

See the appendix at the end of this section for supporting analysis.

This conclusion was confirmed with two independent, nonlinear finite element analyses.

## A Higher Preload Typically Increases Fatigue Life

- As mentioned before herein, clamp stiffness is not linear for a preloaded joint under applied tension.
- Gapping begins closest to the tension walls of the joint members and then proceeds inward toward the bolt as the applied load increases.
- Accordingly, as partial gapping progresses, the percentage of applied load carried by the bolt prior to full gapping,  $n\phi$ , starts out low and increases as the applied load increases relative to the preload.
- Likewise, the bending stress in the flanges or end pads of the joint members increases as gapping progresses.
- Thus, increasing preload for most tension joints provides longer fatigue life, even though the bolt's mean stress (caused by preload) is higher.

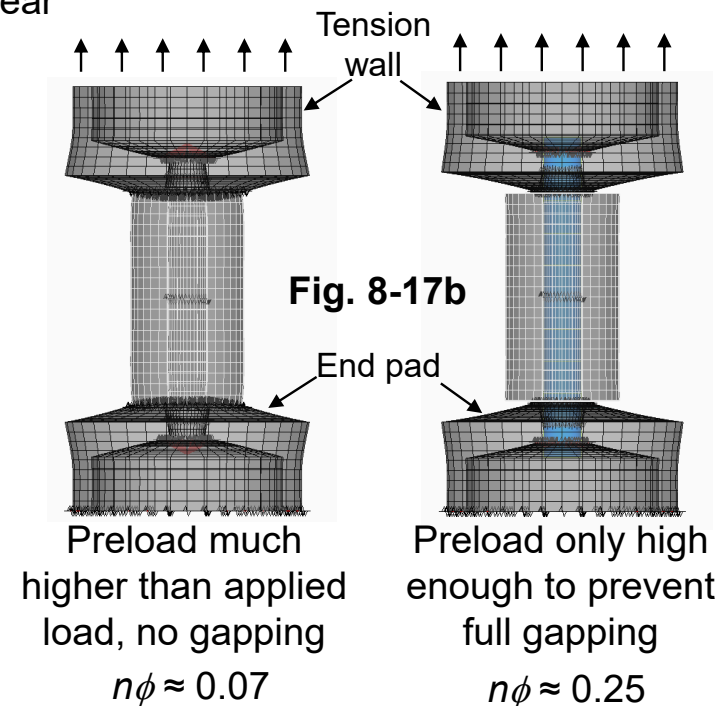

**Even when preloading only high enough to prevent full gapping at the limit load, you can show longer fatigue life by taking advantage of such nonlinearity in fatigue analysis (e.g., through use of a detailed finite element model). Flight vehicles and their components see far more cycles of low load than high load over their life cycles.**

## Can Preload Be Too High?

Potential outcome of high preload	Discussion
Yielding occurs, bolts break, or threads strip while torquing, during which the bolt sees combined tension and torsion.	Minor yielding is not normally a concern. Using up much of the material's elongation, breaking bolts, or stripping threads while torquing is a valid concern. Reduce installation torque if any of these is the case. (Threads won't strip if you've matched nut or insert strength to that of the bolt.)
The clamped parts are crushed by preload alone or by combination of preload and applied tensile load.	Valid concern only when clamping brittle nonmetallic materials (e.g., epoxy washer).
One or more materials in the fastening system yields under the design yield tensile load combined with preload.	Such yielding is not detrimental for most joints that are designed not to gap at limit load. (Addressed in Sec. 9 herein.)
The fastening system has lower ultimate strength under applied loads, i.e., the joint can carry less applied load as a result of preload.	Valid concern for applied tension when clamping nonmetallic materials with low modulus of elasticity (e.g., rubber gasket used to seal a joint). Rarely a concern for all-metallic joints, for which tests show the ultimate strength is the same, with and without preload, even when preload is extremely high. In a well-designed all-metallic joint, gapping occurs before rupture. (Addressed in Sec. 9.)
The bolt fails or is weakened from stress-corrosion cracking*.	Even with corrosion-resistant materials, this is a valid concern for assemblies that will be exposed to corrosive environments on Earth for many years or decades (not typically the case for space and launch vehicles).

\***Stress-corrosion cracking** is the growth of a crack starting at a corrosion pit in a material under sustained tensile stress, often leading to brittle fracture.

## Let's Look at an Actual Load-Deflection Curve for a Tested Bolt

This is a scaled plot of a load-deflection curve for a 1/4" bolt (UNJF) tested in tension to failure, supplied by SPS Technologies in the 1980s.

Material: A-286 treated to 180 ksi minimum tensile strength

Actual rupture stress:

$$\frac{P_{tu}}{A_t} = \frac{8.18}{0.0404} = 202 \text{ ksi}$$

Tensile stress area

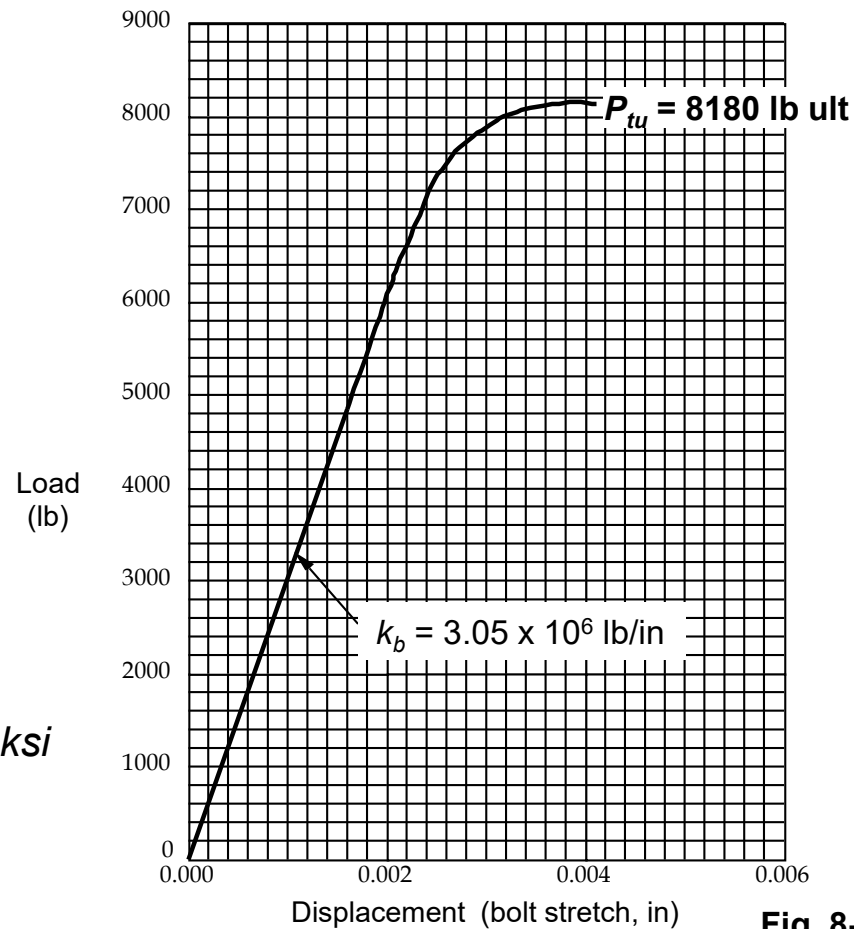

It's not uncommon to receive a bolt that is significantly stronger than advertised.

For our study, we'll assume we have designed for a 202-ksi bolt and have a received one at minimum strength.

Thus, our conclusions should be on the safe side.

Fig. 8-18

## Example Problem 8-d: Could Preload Reduce the Ultimate Tensile Strength of a Joint Using the Bolt on the Preceding Page?

Assumptions for this problem:

- Joint members are made of aluminum alloy.
- The bolt is used with a nut or threaded insert that is matched strength-wise to the bolt to ensure threads don't strip.
- Preload is equal to 85% of the bolt's ultimate strength.

$$\triangleright P_p = 0.85(8180) = 6950 \text{ lb}$$

This is a practical upper limit on preload when preload is achieved by applied torque.

During installation, torsional and tensile stresses interact and typically cause a bolt to break at 80% to 90% of its ultimate tensile strength.

Torsion typically relaxes to insignificant levels shortly after the wrench is removed or when load is applied.

## Example Problem 8-d, continued

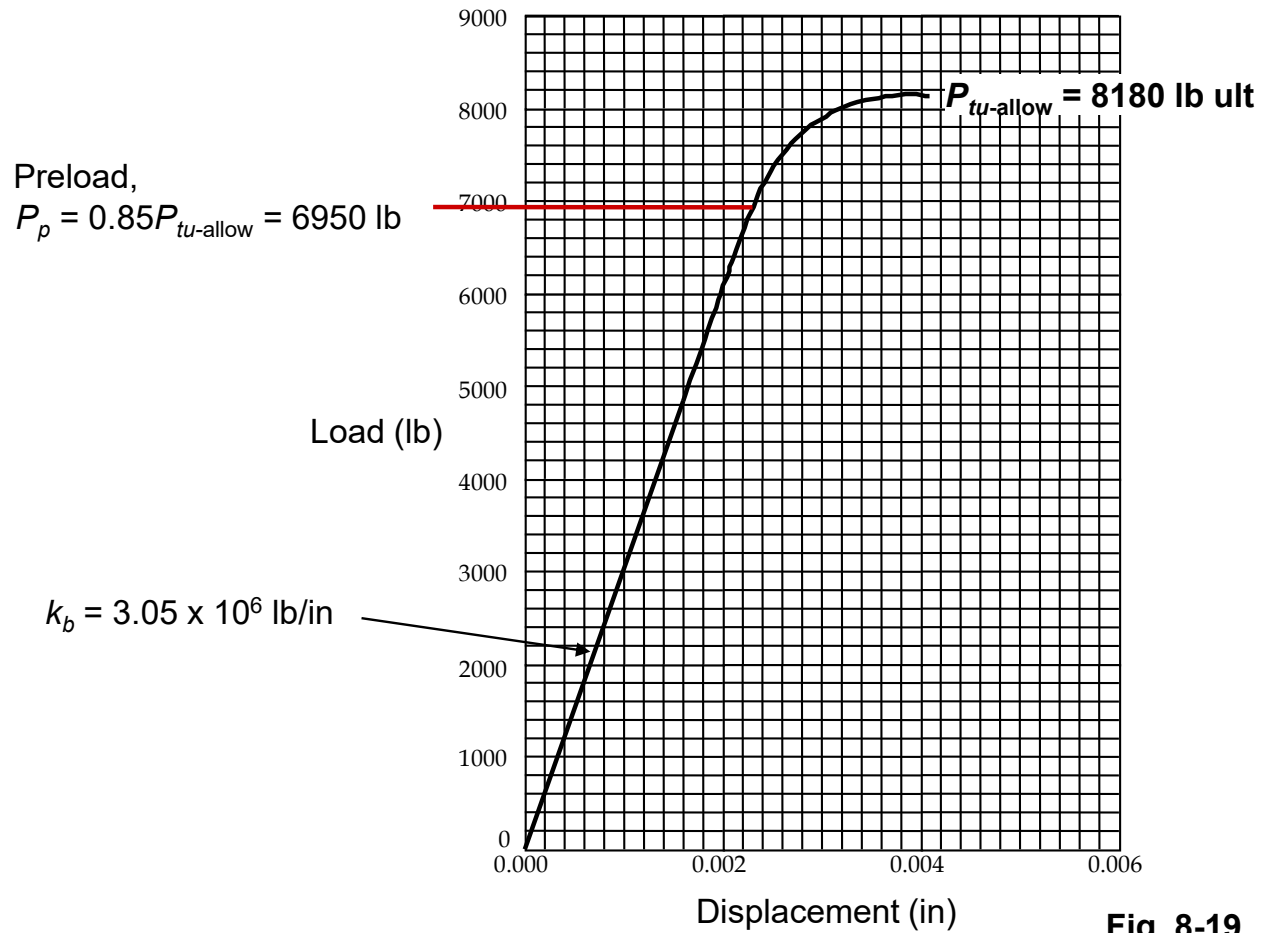

Fig. 8-19

## Example Problem 8-d, continued

The conclusion from Example Problem 8-c is that the load in a preloaded joint with steel or A-286 bolt and aluminum joint members, with no other clamped parts except washers, within reasonable constraints, increases by no more than 25% of the applied tensile load ( $n\phi = 0.25$ ) prior to gapping.

With  $n\phi = 0.25$ , the effective clamp stiffness,  $k'_c$ , is 3 times the bolt stiffness:

$$k'_c = k_b \left( \frac{1}{0.25} - 1 \right) = 3k_b = 3(3.05 \times 10^6) = 9.15 \times 10^6 \text{ lb/in}$$

## Example Problem 8-d, continued

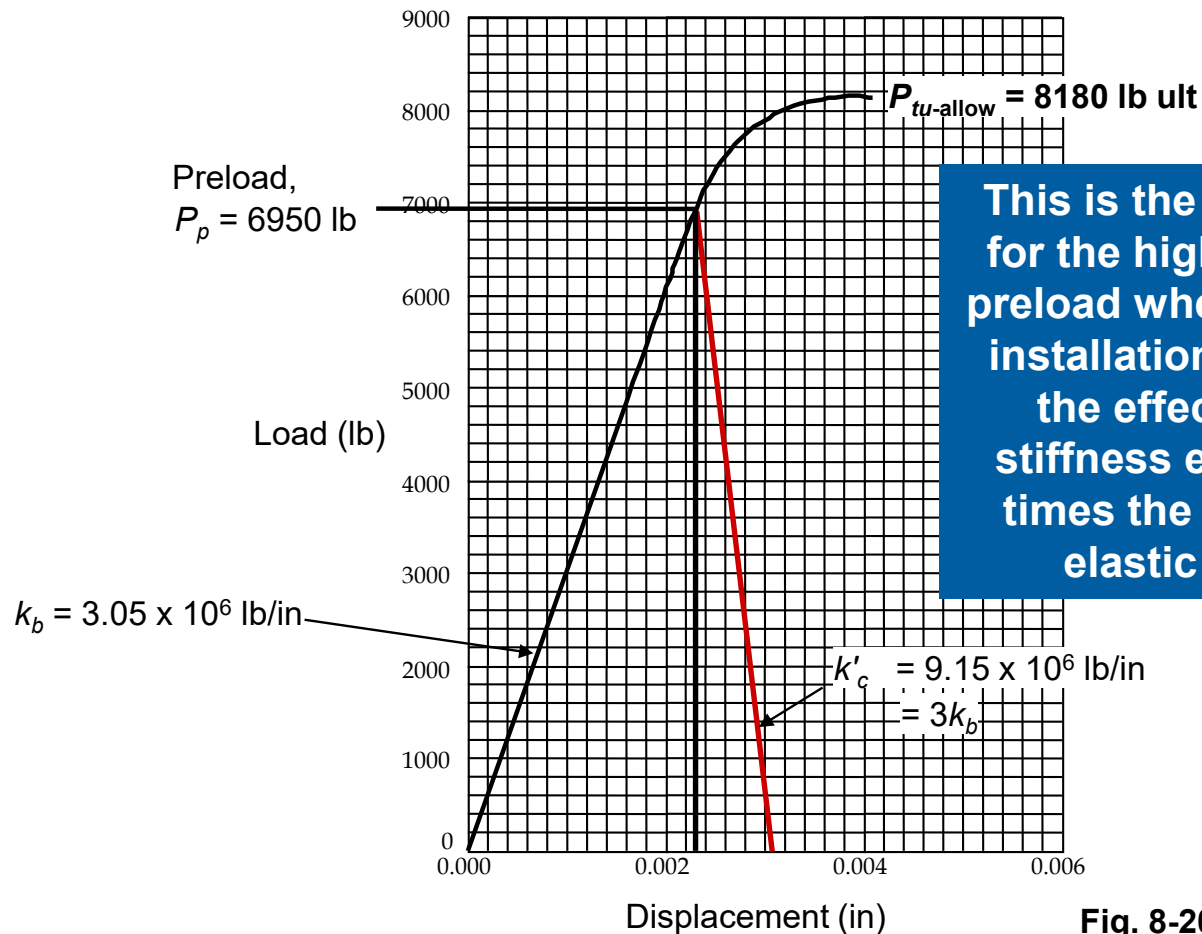

Fig. 8-20

## Example Problem, 8-d, conclusion

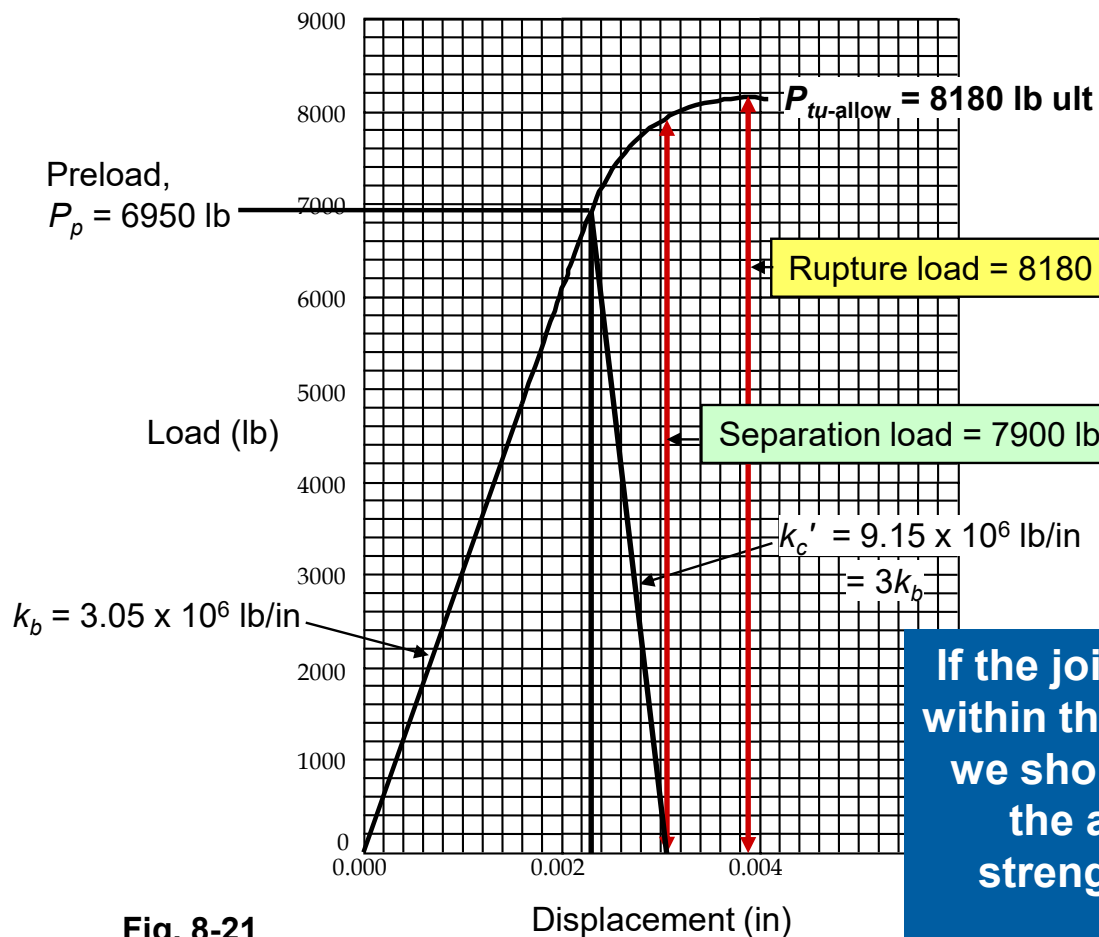

Fig. 8-21

Starting with the highest practical preload when using torque control (85% of  $P_{tu-allow}$ ), the joint will gap at an applied tensile load of 7900 lb.

The applied load that causes the bolt to break is 8180 lb.

Preload does not reduce the ultimate strength of this joint.

If the joint will gap before any part within the fastening system breaks, we should not include preload in the assessment of ultimate strength under applied tensile loads.

## Example Effect of Low Clamp Stiffness (typical of many nonmetallic materials)

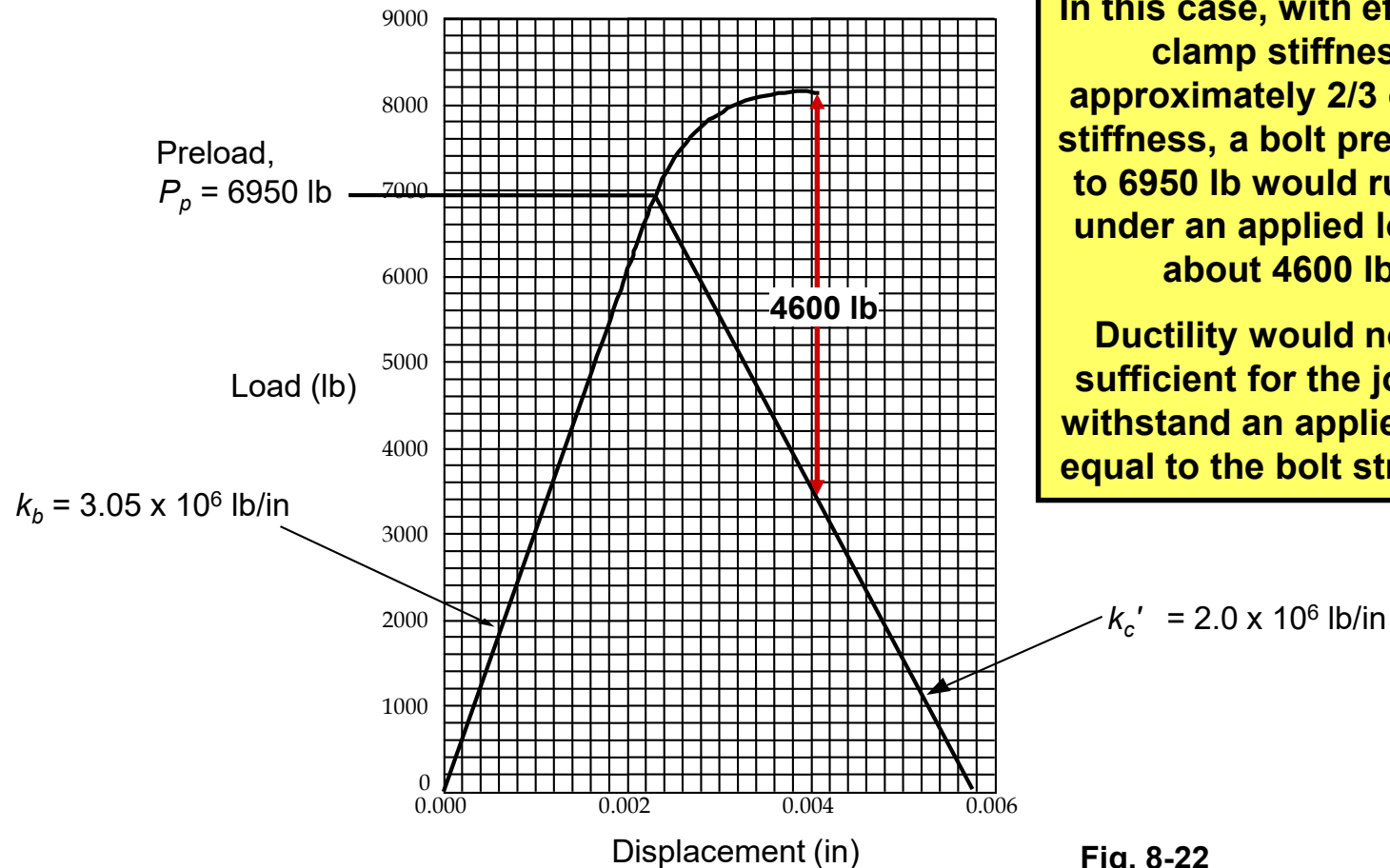

In this case, with effective clamp stiffness approximately 2/3 of bolt stiffness, a bolt preloaded to 6950 lb would rupture under an applied load of about 4600 lb.

Ductility would not be sufficient for the joint to withstand an applied load equal to the bolt strength.

Fig. 8-22

## Some Bolts Exhibit Brittle Failure

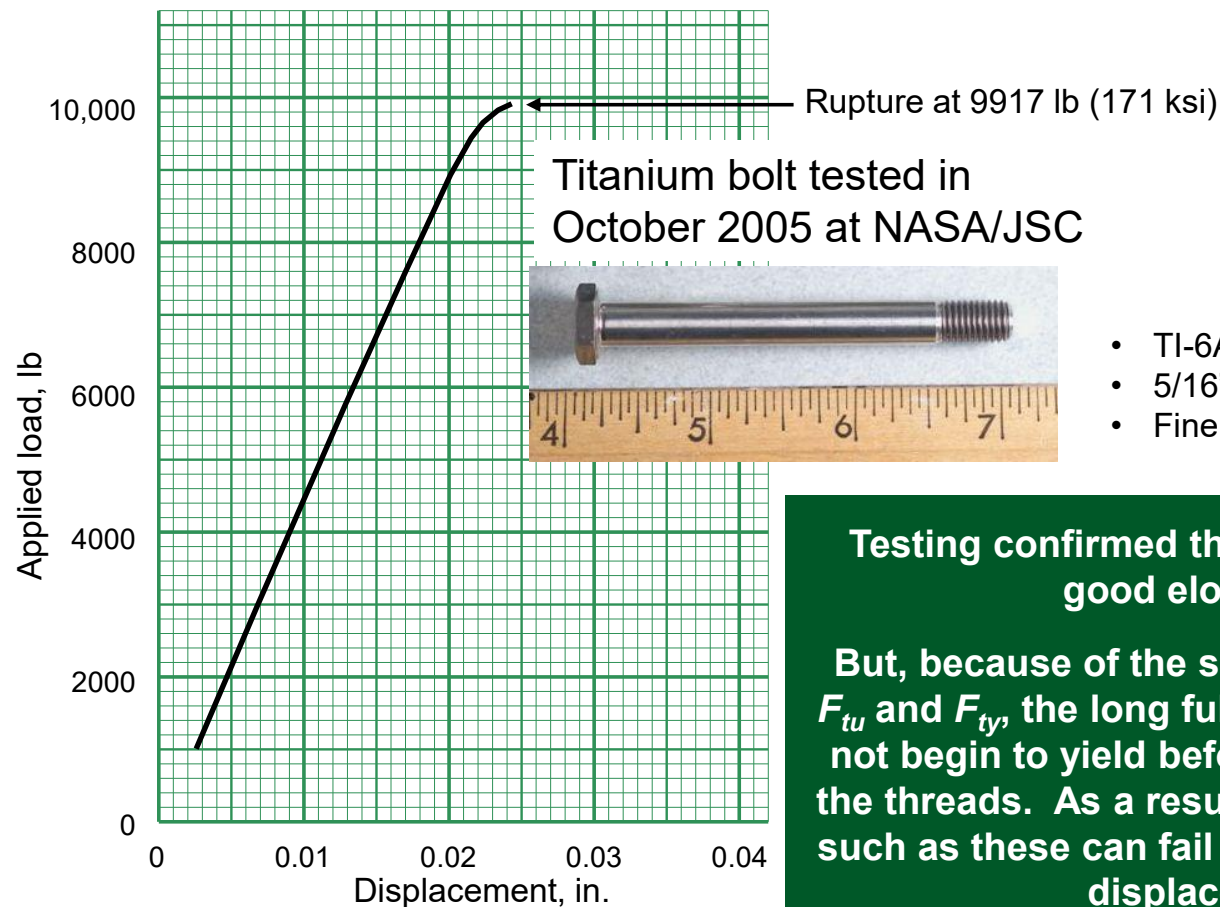

**Thread stripping can exhibit a similar lack of plastic deformation.**

- TI-6AL-4V, STA, 160 ksi
- 5/16" diameter
- Fine threads

**Testing confirmed the material itself had good elongation.**

**But, because of the small spread between  $F_{tu}$  and  $F_{ty}$ , the long full-diameter body does not begin to yield before rupture occurs at the threads. As a result, long titanium bolts such as these can fail with very little plastic displacement!**

Fig. 8-23

## Avoiding Brittle Failure

- Use bolts that are designed for tensile use (relatively thick head; failure would occur at threaded cross section before head fails)
- Use bolts made of materials that have a relatively large difference between ultimate tensile strength and yield strength so that the full-diameter body will begin to yield (exceed proportional limit) before rupture occurs at the threads.
  - Example: A-286 at 160 ksi or lower ultimate tensile strength
  - Avoid ultra-high-strength bolts and titanium bolts in tension joints.
    - Unless the bolt is fully threaded or has a reduced shank
- Make sure the nut or insert can fully develop the strength of the bolt.
  - Thread stripping and other modes of failure associated with internally threaded fasteners can be relatively brittle (little plastic displacement).

**The potential for brittle failure invalidates (and makes potentially unsafe) many of the assumptions used in classical methods of predicting bolt loads (Sec. 4) and makes it more likely that preload will contribute to failure.**

## The Effects of Temperature Change on Preload

When the bolt and fitting materials have different coefficients of thermal expansion (CTEs),  $\alpha$ , the preload will change with temperature.

- If  $\alpha_b < \alpha_c$  (e.g., steel bolt and aluminum fittings), a temperature increase,  $\Delta T$ , will cause the preload to increase.

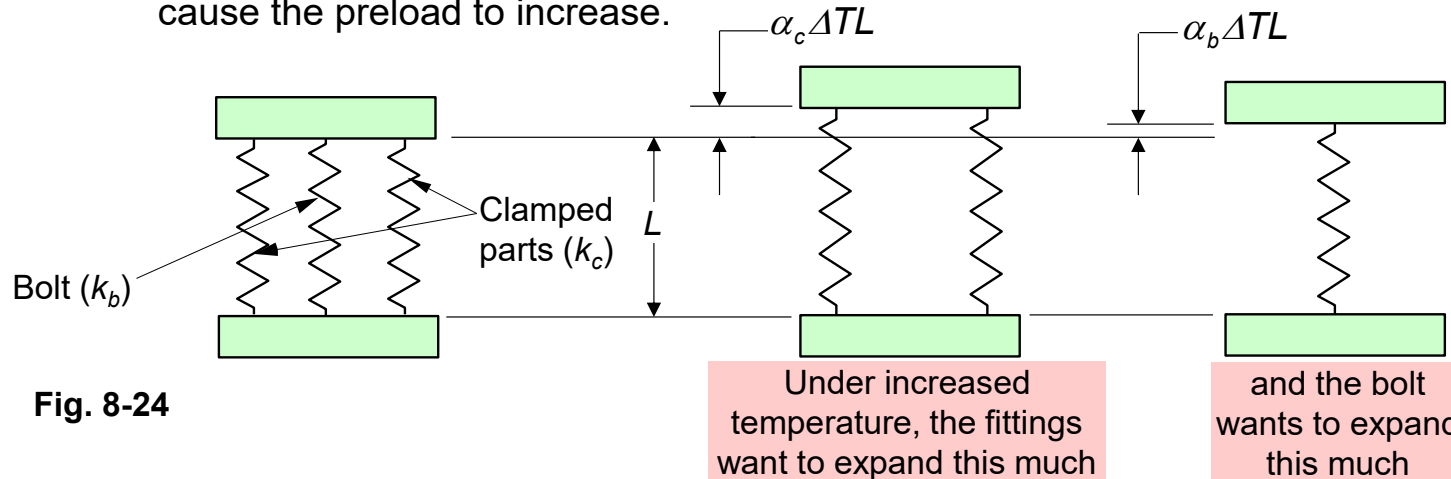

For consistent deflections, the clamped parts and the bolt must expand the same amount:

Based on the assumption that the CTEs do not change significantly with temperature

$$\alpha_c \Delta TL - \frac{P_{\Delta t}}{k_c} = \alpha_b \Delta TL + \frac{P_{\Delta t}}{k_b}$$

$P_{\Delta t}$  = additional tensile force in bolt and compressive force in fittings

(Eq. 8.3) 
$$P_{\Delta t} = \frac{\Delta TL(\alpha_c - \alpha_b)}{(1/k_c + 1/k_b)}$$

← Load-introduction factor not used here, and  $k_c$  should be more conservatively estimated (higher value) than is typical for bolt strength analysis under applied load

## Example Problem 8-e: Thermal Effects on Preload

Same joint as in Example Problem 8-1: **Problem: Estimate the change in preload from a temperature change,  $\Delta T$ , of  $-30^\circ\text{F}$ .**

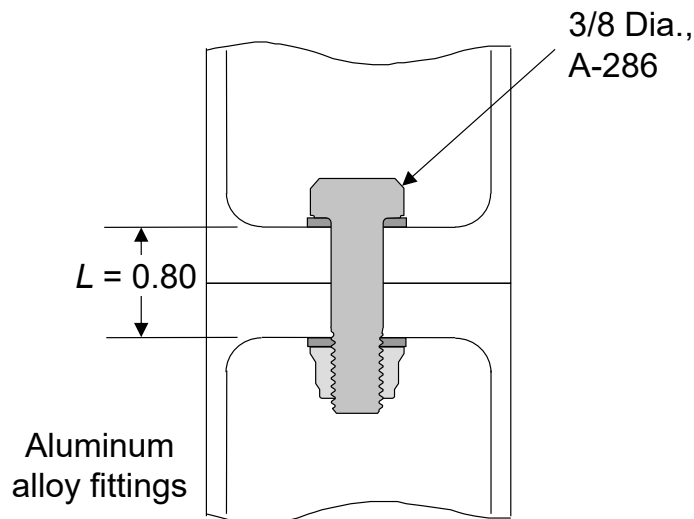

From Fig. 8-14

To simplify this example, let's assume the washer material has the same  $\alpha$  as the bolt material, so we can ignore the washers and base the analysis on length  $L = 0.80$ "

At room temperature,

$$\alpha_c = 12.7 \times 10^{-6} \text{ in/in/F} \quad \alpha_b = 9.0 \times 10^{-6} \text{ in/in/F}$$

From Example Problem 8-1, based on linear-elastic theory:

$$k_c = 4.73 \times 10^6 \text{ lb/in} \quad k_b = 2.39 \times 10^6 \text{ lb/in}$$

However, the above value for  $k_c$  was intentionally estimated on the low side of uncertainty to be conservative for bolt analysis under applied loads. Here, a higher value of  $k_c$  is more conservative. Let's assume  $k_c$  is twice the value shown above, or  $9.46 \times 10^6 \text{ lb/in}$ .

continued

## Example 8-4: Thermal Effects on Preload (continued)

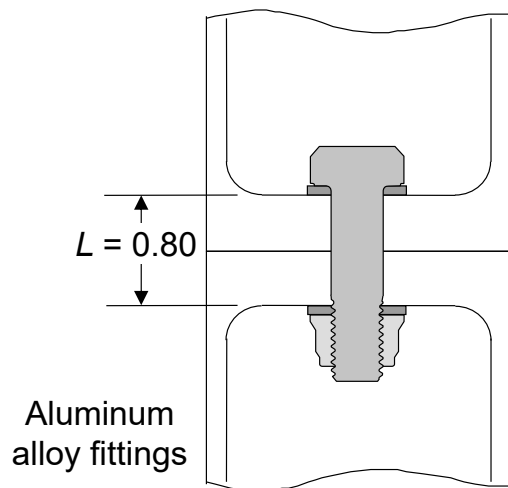

Using Eq. 8.3 and linear-elastic theory:

$$P_{\Delta t} = \frac{\Delta T L (\alpha_c - \alpha_b)}{(1/k_c + 1/k_b)}$$

$$P_{\Delta t} = \frac{-30(0.80)(12.7 - 9.0)(10^{-6})}{\left( \frac{1}{9.46 \times 10^6} + \frac{1}{2.39 \times 10^6} \right)}$$

$$= -170 \text{ lb} \quad (\text{preload loss})$$

- Notes:
- If significant, thermal expansion or contraction of the washers should be included in the analysis when the CTE is different than the bolt material's CTE.
  - Consider also how the material properties, such as  $E$  and  $\alpha$ , change with temperature when calculating how preload changes with temperature.



### Table 8-4. Temperature Effects on Preload for A-286 Bolts and Aluminum Joint Members: Through Bolts with A-286 Washers

Assumptions:		A-286 bolt, fine threads	$E_b =$	29000000	psi									Delta T (°F)	1
		Aluminum joint members	$E_c =$	10000000	psi									CTE-bolt (in/in/°F)	9.00E-06
		Two A-286 washers: #4 through #8: two plain washers ( $t = 0.032$ )												CTE-fittings (in/in/°F)	1.27E-05
		#10 through 1/2": countersunk ( $t = 0.078$ ) under head and plain ( $t = 0.063$ ) under nut													
		Through bolts with nuts	Total thickness of joint members (L in Fig. 8-10) varied between $4D$ and $1.5D$												
		$K_c$ for thermal effects is twice the $K_c$ calculated with 30-degree frustums													
Bolt	Basic major dia, $D$	Full body area, $A_s$	Tensile-stress area, $A_t$	Assumed effective area, $A_{eff}$	Bolt-head or washer-face dia, $d_{wf}$	Average washer thickness, $t_w$	Initial dia. of compress. area, $d_c$	Total clamp thickness, $L$ (in)	Effective bolt length, $L_b$	Bolt stiffness, $K_b$	Clamp stiffness, $K_c$	$K_c$ for thermal effects (lb/in)	Change in preload (lb)	Change in bolt stress (ksi)	
NAS 1351 (#4)	0.112	0.0099	0.0066	0.0089	0.180	0.032	0.217	0.448	0.602	427886	1530624	3061247	0.622	0.094	
	0.112	0.0099	0.0066	0.0089	0.180	0.032	0.217	0.168	0.322	800424	2560150	5120299	0.430	0.065	
NAS 1351 (#6)	0.138	0.0150	0.0101	0.0135	0.222	0.032	0.259	0.552	0.726	539438	1781597	3563195	0.957	0.094	
	0.138	0.0150	0.0101	0.0135	0.222	0.032	0.259	0.207	0.381	1027393	2946937	5893874	0.670	0.066	
NAS 1351 (#8)	0.164	0.0211	0.0147	0.0192	0.266	0.032	0.303	0.656	0.851	654335	2058193	4116387	1.37	0.093	
	0.164	0.0211	0.0147	0.0192	0.266	0.032	0.303	0.246	0.441	1262397	3385446	6770893	0.97	0.066	
NAS 1351 (#10)	0.190	0.0284	0.0200	0.0258	0.308	0.071	0.390	0.760	1.054	711161	2876648	5753295	1.78	0.089	
	0.190	0.0284	0.0200	0.0258	0.308	0.071	0.390	0.285	0.579	1294583	4906716	9813432	1.21	0.060	
NAS 1954	0.250	0.0491	0.0404	0.0465	0.398	0.071	0.479	1.000	1.341	1005186	3355653	6711307	3.23	0.080	
	0.250	0.0491	0.0404	0.0465	0.398	0.071	0.479	0.375	0.716	1882617	5593115	11186231	2.24	0.055	
NAS 1955	0.313	0.0767	0.0640	0.0729	0.460	0.071	0.541	1.250	1.641	1288111	3487351	6974702	5.03	0.079	
	0.313	0.0767	0.0640	0.0729	0.460	0.071	0.541	0.469	0.860	2458611	5602030	11204060	3.50	0.055	
NAS 1956	0.375	0.1104	0.0951	0.1058	0.523	0.071	0.604	1.500	1.941	1581369	3650649	7301297	7.21	0.076	
	0.375	0.1104	0.0951	0.1058	0.523	0.071	0.604	0.563	1.004	3058731	5700489	11400977	5.02	0.053	
NAS 1957	0.438	0.1503	0.1288	0.1439	0.648	0.071	0.729	1.750	2.241	1861786	4543286	9086573	10.01	0.078	
	0.438	0.1503	0.1288	0.1439	0.648	0.071	0.729	0.657	1.148	3634374	7186048	14372097	7.05	0.055	
NAS 1958	0.500	0.1963	0.1717	0.1890	0.710	0.071	0.791	2.000	2.541	2156508	4699358	9398717	12.98	0.076	
	0.500	0.1963	0.1717	0.1890	0.710	0.071	0.791	0.750	1.291	4244528	7283780	14567561	9.12	0.053	

Increase in bolt tensile stress at the threads for a 1°F temperature increase



**Table 8-5. Temperature Effects on Preload for A-286 Bolts and Aluminum Joint Members: Fixed Fasteners with A-286 Washers**

Assumptions:		A-286 bolt, fine threaded	$E_b =$	29000000	psi								Delta T (°F)	1
		Aluminum joint members	$E_c =$	10000000	psi								CTE-bolt (in/in/°F)	9.00E-06
		A-286 washer under head; washer thickness 0.032" for #4 - #8, and 0.078" for #10 - 1/2"										CTE-fittings (in/in/°F)	1.27E-05	
		Blind fasteners into threaded inserts		Thickness of joint member with through hole ( $t_1$ in Fig. 8-15) varied from $2D$ to $1D$										
		Effective clamp thickness, $L = t_1 + D/2$												
		$K_c$ for thermal effects is twice the $K_c$ calculated with 30-degree frustums												

Bolt	Body dia, D	Body area, $A_b$	Tensile-stress area, $A_t$	Assumed effective area, $A_{eff}$	Bolt-head or washer-face dia, $d_{wf}$	Initial dia. of compress. area, $d_c$	Thickness of part with through hole, $t_1$	Effective bolt length, $L_b$	Bolt stiffness, $K_b$	Clamp stiffness, $K_c$	Effective clamp thickness, L	$K_c$ for thermal effects (lb/in)	Change in preload (lb)	Change in bolt stress (ksi)
NAS 1351 (#4)	0.112	0.0099	0.0066	0.0082	0.180	0.217	0.224	0.357	668594	1904046	0.28	3808092	0.6	0.089
	0.112	0.0099	0.0066	0.0082	0.180	0.217	0.112	0.245	974487	2560150	0.168	5120299	0.5	0.077
NAS 1351 (#6)	0.138	0.0150	0.0101	0.0125	0.222	0.259	0.276	0.432	841990	2204620	0.345	4409241	0.9	0.089
	0.138	0.0150	0.0101	0.0125	0.222	0.259	0.138	0.294	1236942	2946937	0.207	5893874	0.8	0.077
NAS 1351 (#8)	0.164	0.0211	0.0147	0.0179	0.266	0.303	0.328	0.508	1024200	2540197	0.41	5080395	1.3	0.088
	0.164	0.0211	0.0147	0.0179	0.266	0.303	0.164	0.344	1513050	3385446	0.246	6770893	1.1	0.076
NAS 1351 (#10)	0.190	0.0284	0.0200	0.0242	0.308	0.398	0.380	0.629	1114653	3756425	0.475	7512850	1.7	0.085
	0.190	0.0284	0.0200	0.0242	0.308	0.398	0.190	0.439	1597077	5120717	0.285	10241434	1.5	0.073
NAS 1954	0.250	0.0491	0.0404	0.0447	0.398	0.488	0.500	0.803	1615899	4315227	0.625	8630454	3.1	0.078
	0.250	0.0491	0.0404	0.0447	0.398	0.488	0.250	0.553	2346414	5810416	0.375	11620831	2.7	0.067
NAS 1955	0.313	0.0767	0.0640	0.0703	0.460	0.550	0.625	0.984	2072782	4395808	0.78125	8791615	4.8	0.076
	0.313	0.0767	0.0640	0.0703	0.460	0.550	0.313	0.672	3037047	5803497	0.46875	11606993	4.2	0.065
NAS 1956	0.375	0.1104	0.0951	0.1028	0.523	0.613	0.750	1.166	2557208	4532347	0.9375	9064695	6.9	0.073
	0.375	0.1104	0.0951	0.1028	0.523	0.613	0.375	0.791	3770305	5892111	0.5625	11784221	5.9	0.063
NAS 1957	0.438	0.1503	0.1288	0.1396	0.648	0.738	0.875	1.347	3005299	5643967	1.09375	11287934	9.6	0.075
	0.438	0.1503	0.1288	0.1396	0.648	0.738	0.438	0.910	4448900	7383381	0.65675	14766762	8.3	0.065
NAS 1958	0.500	0.1963	0.1717	0.1840	0.710	0.800	1.000	1.528	3492617	5775653	1.25	11551306	12.4	0.072
	0.500	0.1963	0.1717	0.1840	0.710	0.800	0.500	1.028	5191360	7472956	0.75	14945911	10.7	0.062

Increase in bolt tensile stress at the threads for a 1° F temperature increase

## Summary of Tables 8-4 and 8-5

Given:

- A-286 bolts, #4 through ½” in diameter, and aluminum joint members.
- A-286 washers.
- For bolt-nut assemblies: total thickness of joint members between 1.5 and 4.0 times bolt diameter.
- For bolt-insert assemblies (fixed fasteners): joint member with through hole has thickness between 1.0 and 2.0 times bolt diameter.
- Temperature change is not great enough to cause significant differences in material properties.

The method presented herein for computing how temperature change affects preload results in the following conclusion:

**For joints fitting the above description, tensile stress in the bolt increases by no more than 100 psi for each degree Fahrenheit of temperature increase.**

## Key Points from Sec. 8

- A common goal in designing a tension joint is for the bolt load not to change much with applied load, thus extending fatigue life. Strategies:
  - Reduce stiffness of the bolt load path.
  - Thicken end pads and use washers.
  - Increase preload.
- The bolt tensile load cannot be lower than the applied tensile load.
  - Analysis that says otherwise is based on improper use of load-sharing equations.
- Use of a load-introduction factor of 0.5 for a standard joint without non-load-bearing spacers is justified by mechanics, substantiated by analysis and test, and accepted by NASA.
- For almost any practical all-metallic joint (no nonmetallic parts)—with a bolt designed for tensile use (would break at the threaded cross section before the head fails) and a nut or threaded insert that can fully develop the bolt strength—gapping occurs under applied tensile load before the bolt breaks.

## Appendix for Sec. 8

# Analysis for Example Problem 8-c

## Example Problem 8-c: Problem Statement

For a preloaded joint, prior to separation, determine an upper bound for the percentage of applied load by which the bolt load increases, given the following:

- Steel bolt
- Aluminum fittings (joint members)
- $e/D \geq 1.5$  for all clamped parts other than washers
- Load-introduction factor,  $n \leq 0.9$

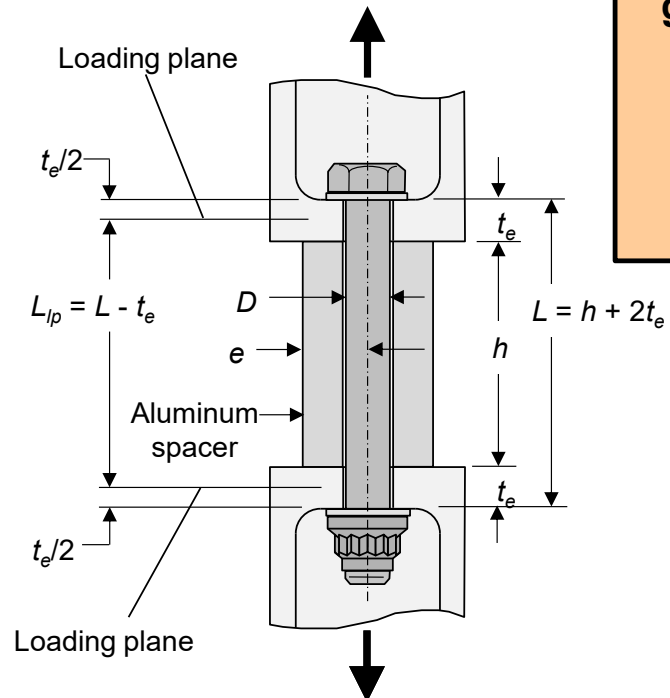

- The joint shown at left is intended to represent the worst-case joint geometry.
- The solution is worked out to enable inclusion of washers and variation of dimensions.
- But the final result is shown for the worst-case situation in which there are no washers,  $L_{ip} = 0.9$ , and  $e = 1.5D$ .

Continued

## Example Problem 8-c, continued

Start with a simple tension joint without spacer:

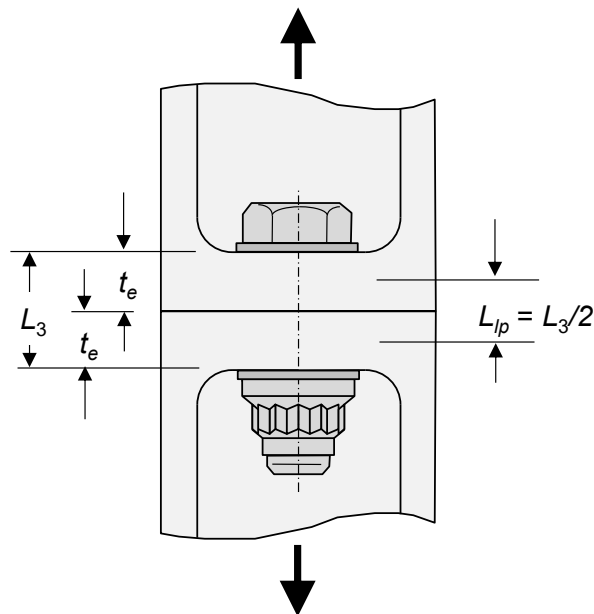

Bolt load  $P_{tb} = P_p + n\phi P_t$

Preload  $P_p$

Applied load  $P_t$

$$\phi = \frac{k_b}{k_b + k_c}$$

Bolt stiffness  $k_b$

Clamp stiffness  $k_c$

Load-introduction factor,  $n = \frac{L_{lp}}{L_3} = 0.5$

Continued

## Example Problem 8-c, continued

# Bolt Stiffness for Joint without Spacer

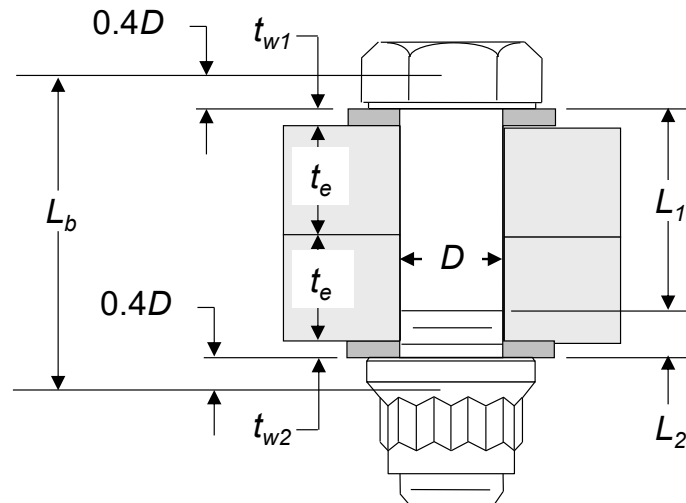

For a through bolt, use Eq. 8.1c:

$$k_b = E_b \left[ \frac{L_1 + 0.4D}{A_s} + \frac{L_2 + 0.4D}{A_t} \right]^{-1}$$

$E_b$  = elastic modulus of bolt material

$D$  = Basic diameter

$A_s$  = cross-sectional area of full-diameter ( $D$ ) body

$A_t$  = tensile stress area

$$L_2 = 2p$$

$$L_1 = 2t_e + t_{w1} + t_{w2} - L_2$$

$$A_s = \frac{\pi D^2}{4}$$

$$A_t = \frac{\pi}{4} (D - 0.6495p)^2 \quad \leftarrow \text{See Sec. 2}$$

Continued

## Example Problem 8-c, continued

# Clamp Stiffness for Joint without Spacer

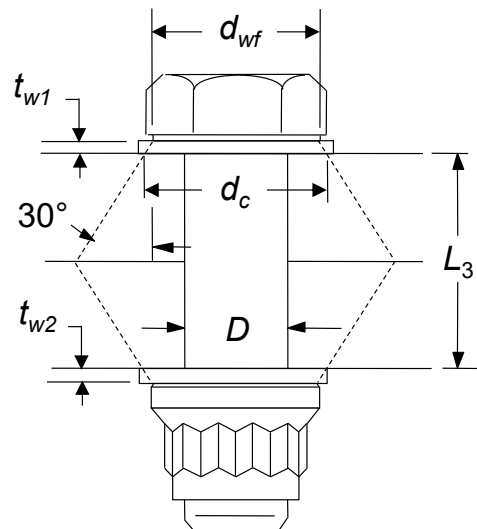

To estimate clamp stiffness,  $k_c$ , use Eq. 8.1f, where

$$\begin{aligned} d_c &= d_{wf} + 2t_w \tan 30^\circ \\ &= d_{wf} + 1.155t_w \end{aligned}$$

$t_w$  = average thickness  
of the two washers

Assume  $d_{wf}$  is the average washer-face diameter for the bolt head and the nut.

$$k_c = \frac{1.81E_c D}{2 \ln \left\{ \frac{(0.577L_3 + d_c - D)(d_c + D)}{(0.577L_3 + d_c + D)(d_c - D)} \right\}} \quad (\text{Eq. 8.1f})$$

Continued

Example Problem 8-c, Joint without Spacer continued

## Idealization when Including the Load-introduction Factor

- Applied load must further compress the washer and the fitting material just under the washer in order to go into the bolt.
- Thus, part of the clamp stiffness,  $k_c$ , calculated from 30° frustums is actually in the bolt load path, reducing the effective stiffness of the bolt.

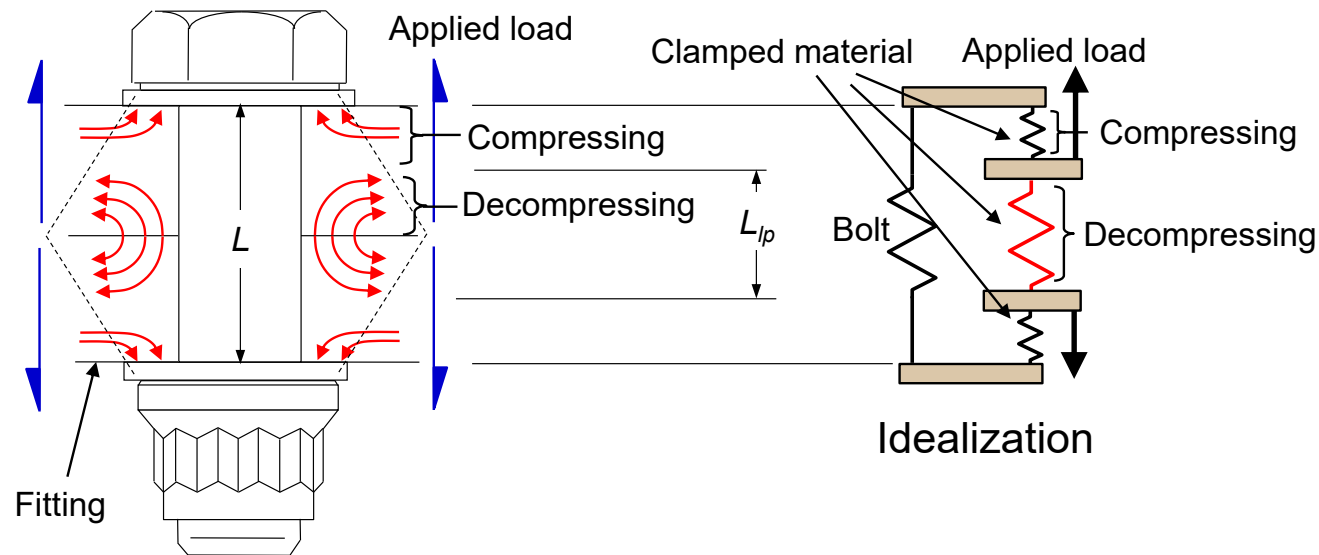

- To account for this effect, the computed percentage of applied load by which the bolt load increases is reduced by the load-introduction factor,  $n$ .

Continued

## Example Problem 8-c, Joint without Spacer continued Idealization with Effective Stiffness Values

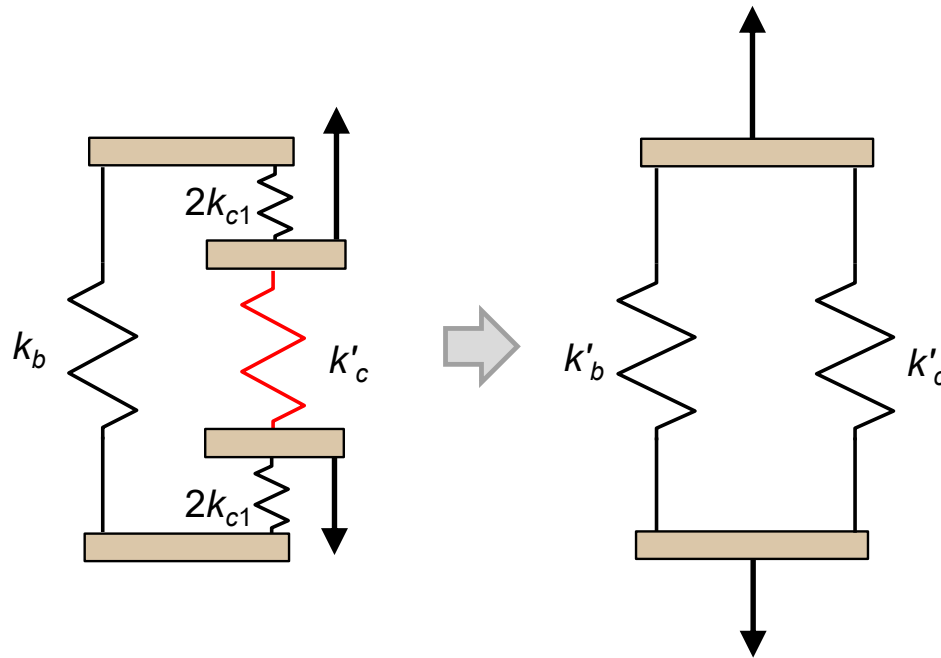

Effective clamp stiffness and effective bolt stiffness:

$$k'_c = \left[ \frac{1}{k_c} - \frac{1}{k_{c1}} \right]^{-1}$$

$$k'_b = \left[ \frac{1}{k_b} + \frac{1}{k_{c1}} \right]^{-1}$$

where  $k_{c1} = 2k_c$

Effective stiffness factor:

$$\phi' = \frac{k'_b}{k'_b + k'_c} = n\phi = \frac{0.5k_b}{k_b + k_c}$$

Continued

## Example Problem 8-c, continued

### Now We Introduce a Spacer

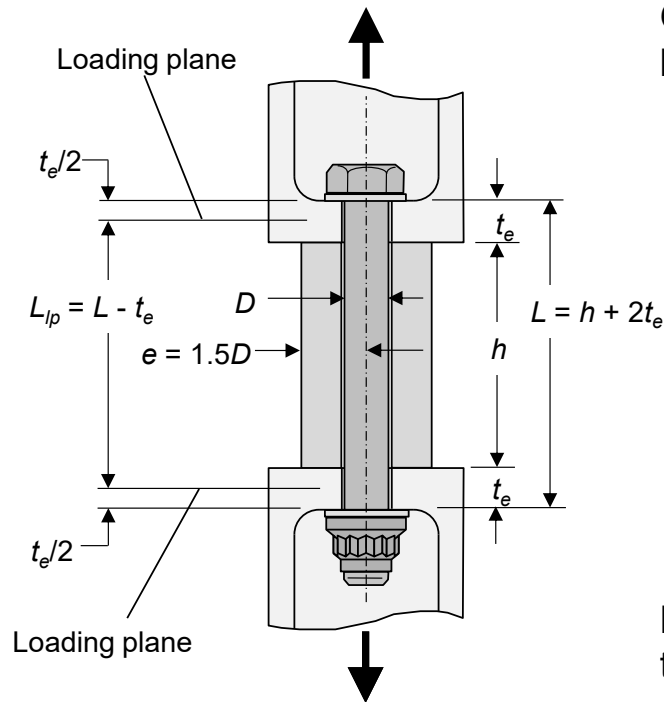

One approach to determine the percentage of applied load by which the bolt load increases:

1. Calculate new values of  $k_b$  and  $k_c$ , starting with the values for the case in which there is no spacer and including the effects of additional springs in series based on  $AE/h$  for both the bolt and the spacer.
2. Compute  $\phi$  for the new  $k_b$  and  $k_c$  values.
3. Compute a load-introduction factor,  $n = L_{ip}/L$
4. Compute  $n\phi$

But a more accurate method, based on the assumption that the model used in the previous pages is accurate ( $n = 0.5$  without a spacer), is to build off the idealization of the no-spacer case by including the new springs in series. (See next page.)

Continued

## Example Problem 8-c, continued Idealization With Spacer

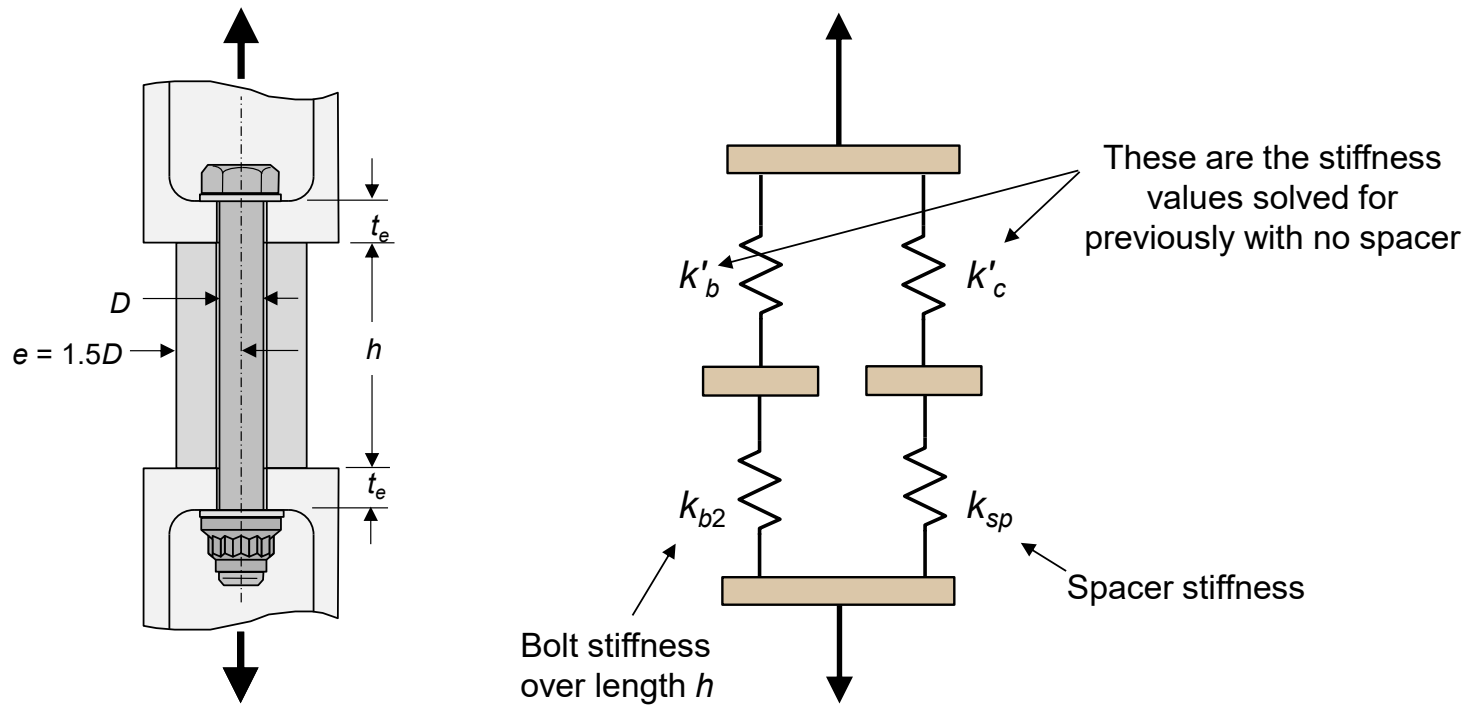

$$k_{b2} = \frac{A_s E_b}{h} \quad \text{where} \quad A_s = \frac{\pi D^2}{4}$$

Continued

### Example Problem 8-c, continued

## Spacer Stiffness, $k_{sp}$

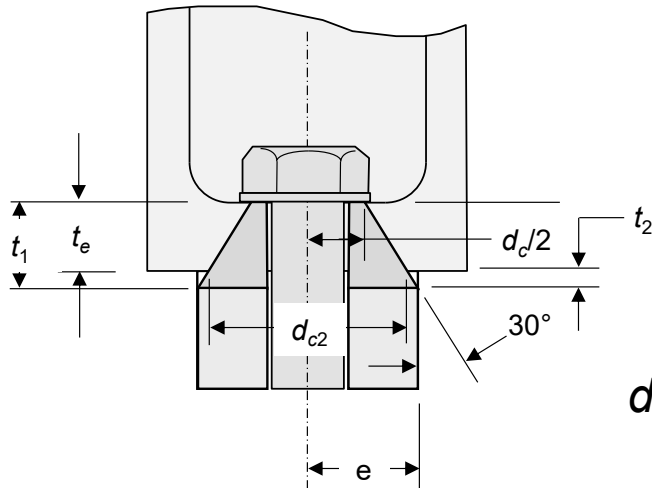

$$t_1 = \frac{e - \frac{d_c}{2}}{\tan 30^\circ} = 1.732e - 0.866d_c$$

$$t_2 = t_1 - t_e$$

$$d_{c2} = d_c + 2t_e(\tan 30^\circ) = d_c + 1.155t_e$$

Based on the 30° frustum model, not all of the spacer is effective. We need to determine the stiffness of the effective volume shown at right:

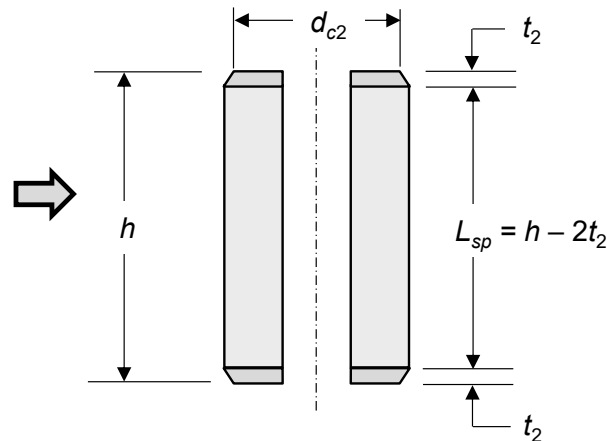

Continued

## Example Problem 8-c, continued Spacer Stiffness, $k_{sp}$ , continued

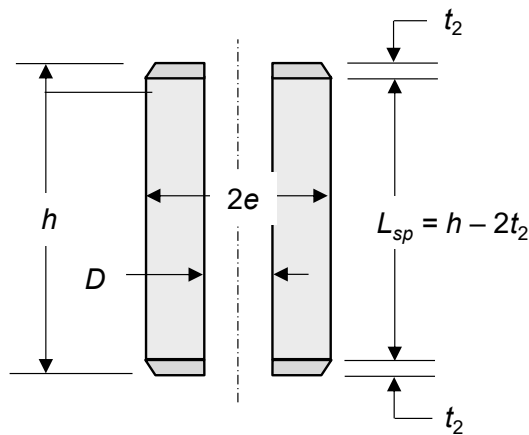

Two springs in series make up the spacer stiffness:

$$k_{sp} = \left[ \frac{1}{k_{sp1}} + \frac{1}{k_{sp2}} \right]^{-1}$$

$$k_{sp1} = \frac{A_{sp} E_c}{L_{sp}} \quad \text{where} \quad A_{sp} = \frac{\pi}{4} \left[ (2e)^2 - D^2 \right]$$

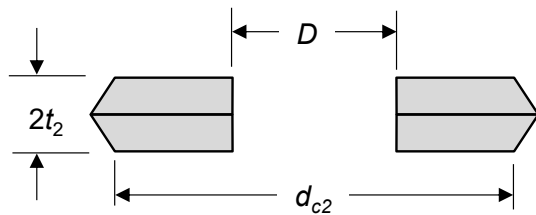

$$k_{sp2} = \frac{1.81 E_c D}{2 \ln \left\{ \frac{[0.577(2t_2) + d_{c2} - D][d_{c2} + D]}{[0.577(2t_2) + d_{c2} + D][d_{c2} - D]} \right\}}$$

Continued

### Example Problem 8-c, continued Final Calculations

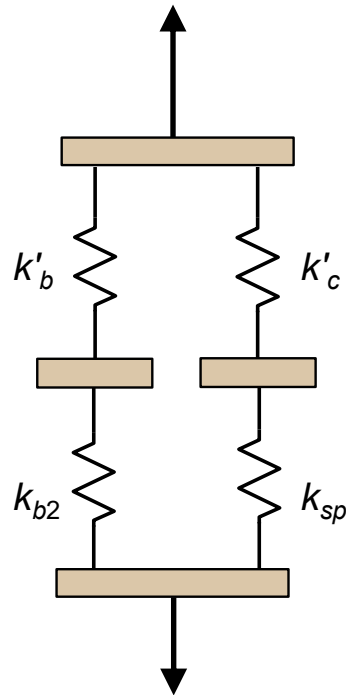

$$k_b'' = \left[ \frac{1}{k'_b} + \frac{1}{k_{b2}} \right]^{-1}$$

$$k_c'' = \left[ \frac{1}{k'_c} + \frac{1}{k_{sp}} \right]^{-1}$$

Bolt load
Preload
Applied load  

$$P_{tb} = P_p + \phi'' P_t$$

where

$$\phi'' = \frac{k_b''}{k_b'' + k_c''} \quad \left| \begin{array}{l} \text{Used in place of } n\phi \end{array} \right.$$

Continued

## Example Problem 8-c, conclusion

Given:		Calculated:	
Nominal diameter for bolt, D	0.375	1. Assuming no spacer	
Threads per inch	24	Shank area, $A_s$	0.1104
Thread pitch	0.042	Tensile-stress area, $A_t$	0.0951
Washer-face diameter for head, $d_{wh}$	0.523	Spacer area, $A_{sp}$	0.8836
Nut washer-face diameter, $d_n$	0.591	L2	0.083
Average washer-face dia, $d_{wf}$	0.557	L1	0.667
Thickness of washer under head, $tw_1$	0.000	Blot stiffness, $k_b$	2.94E+06
Thickness of washer under nut, $tw_2$	0.000	dc	0.557
Average washer thickness, $tw$	0.000	L3	0.75
End-pad thickness (fitting), $t_e$	0.375	kc	4.26E+06
Spacer thickness, $h$	3.000	$\phi$	0.409
Spacer radius, $e$	0.563	0.5 $\phi$	0.204
Spacer diameter, $2e$	1.125	kc1	8.53E+06
Elastic modulus for bolt, $E_b$	2.90E+07	k'c	8.53E+06
Elastic modulus for fittings & spacer, $E_c$	1.05E+07	k'b	2.19E+06
L	3.750	$\phi'$	0.204
		2. Including spacer	
		kb2	1.07E+06
		t1	0.491888
		t2	0.117
		Lsp	2.766
		dc2	0.990
		ksp1	3.35E+06
		ksp2	3.43E+07
		ksp	3.05E+06
		k"b	7.18E+05
		k"c	2.25E+06
		Bolt load increases by this fraction of applied tensile load: $\phi''$	0.242

Load-introduction factor is

$$n = \frac{L - t_e}{L} = 0.9$$

This value, although not used in the analysis, indirectly affects the answer.

### Conclusion:

For a preloaded joint meeting the specified constraints, prior to separation, the bolt load will increase by no more than 25% of the applied load.

## 9. Fastening System Analysis per NASA-STD-5020B

- Objectives and Summary
- Nominal, Maximum, and Minimum Preloads
- Tensile Loading: Ultimate-strength Analysis
- Separation Analysis
- Tensile Loading: Yield-strength Analysis
- Shear Loading: Ultimate-strength Analysis
- Interaction of Tension, Shear, and Bending
- Joint-slip Analysis
- Fatigue

### Appendices:

9A.1: Additional data and requirements from NASA-STD-5020B pertaining to preload calculation

9A.2: Accounting for bolt bending in a shimmed single-shear joint

9A.3: Justification for low likelihood of fatigue failure: the original report, which was condensed to become the main part of NASA-STD-5020B  
Appendix C

Permission is granted by Instar for anyone to freely copy, distribute, and print this material, but only in its unaltered form. This section may be separately copied or printed, but only in its entirety, including this page and with headers and footers intact. Unaltered individual figures and tables and portions of text may be copied or used, but only with text in quotes and with the following statement "Source: Design and Analysis of Bolted Joints (DABJ) course book, Thomas P. Sarafin, Instar Engineering and Consulting, Inc. Reproduced with permission." The date of last revision also should be included in the reference. If you have questions, contact [tom.sarafin@instarengineering.com](mailto:tom.sarafin@instarengineering.com).

## Original Objectives of NASA-STD-5020 Analysis Criteria

The analysis criteria in NASA-STD-5020 were intended to replace NSTS-08307 (Ref. 7), which was first released in 1989 and then revised in 1998 (Rev A).

Team objectives in developing the 5020 analysis criteria were to ...

- Ensure personnel safety and structural integrity (top priority).
  - Some of the new criteria are justifiably more conservative than NSTS-08307.
  - Others are less conservative but are substantiated by analysis and test.
  - Still others appear to be less conservative but actually lead to more reliable joints.
- Avoid unnecessary conservatism and the associated weight impact.
- (At least for some of us) enable and encourage simple analysis methodology when appropriate.
  - Unnecessary complexity leads to engineers using methods and spreadsheets without understanding them—and being unable to recognize errors.
- Use clear wording to avoid multiple interpretations.
- Resolve on-going arguments regarding bolt analysis.
  - Provide supporting rationale and test data.

## Overview of Changes for NASA-STD-5020A

In 5020A, and still in 5020B, there are no requirements (“shall” statements) for how the analysis must be done or which equations must be used.

- All the equations and methods are in italicized explanatory text or in Appendix A.
- Requirements pertain mostly to analysis criteria rather than to methods.

In my mind, this is an improvement.

Unfortunately, though, there are multiple instances of ambiguous wording in the analysis sections of 5020A & B.

**In this section of the DABJ course, I offer my interpretation and opinion on how to implement the 5020B analysis requirements.**

**As such, I am not speaking for NASA.**

This section does not address all of the guidance provided in 5020B Appendix A.

## What We Will Discover in This Section

when combined with Sec. 8

For most joints ...

- Preload does not reduce ultimate strength under applied loads and thus should not be included in the assessment of ultimate strength.
- Bolt yielding under applied tensile load or temperature change is not detrimental if we can show no gapping at the design separation load using the originally calculated minimum preload. In such a case, there is no need to calculate a yield margin.

**But it's  
important that  
we learn to  
recognize the  
exceptions!  
(to be explored  
in this section)**

## Calculation of Design Loads

Design ultimate tensile and shear loads,  $P_{tu}$  and  $P_{su}$ :

$$P_{tu} = FF_u \cdot FS_u \cdot P_{tL} \quad \leftarrow \text{Limit tensile load}$$

$$P_{su} = FF_u \cdot FS_u \cdot P_{sL} \quad \leftarrow \text{Limit shear load}$$

Ultimate fitting factor

Ultimate factor of safety

Design yield tensile and shear loads,  $P_{ty}$  and  $P_{sy}$ :

$$P_{ty} = FF_y \cdot FS_y \cdot P_{tL}$$

Used for bearing analysis, which is outside the scope of the standard

$$P_{sy} = FF_y \cdot FS_y \cdot P_{sL}$$

Design separation load (tensile),  $P_{sep}$ :

$$P_{sep} = FF_{sep} \cdot FS_{sep} \cdot P_{tL}$$

Separation factor of safety

These equations are not in NASA-STD-5020B. They are included here as a matter of convenience for use in assessing the 5020B analysis criteria.

See definitions in Sec. 1 of this course book.

## The Joint Used for Class Problems in This Section

In class problem 4-2, we calculated the following limit bolt tensile and shear loads:  $P_{tL} = 5590$  lb,  $P_{sL} = 1560$  lb

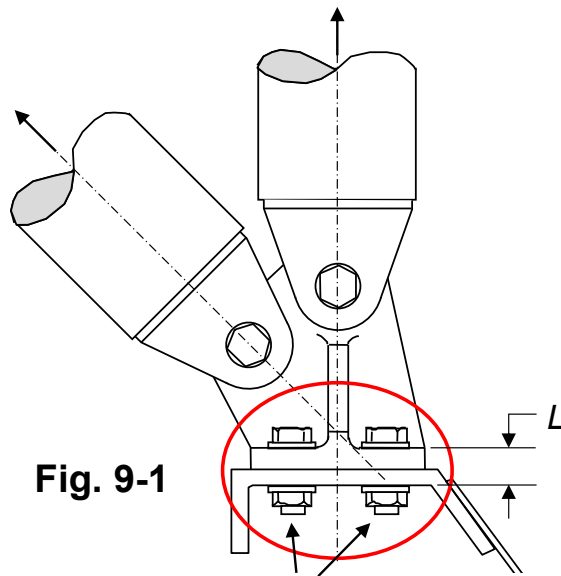

**Fig. 9-1**

Four 3/8"-dia A-286 bolts, with allowable ultimate tensile load (specified strength) of 15,200 lb. The nuts are as strong as the bolts.

The joint members (fittings) are made of aluminum alloy, and total thickness of joint members ( $L$  in Fig. 9-1) is between  $1.5D$  and  $4D$ . The joint is bearing critical.

Given:

- Factors of safety are 1.4 for ultimate, 1.25 for yield, and 1.0 for separation
- Fitting factor = 1.15 for ultimate, 1.0 for yield, and 1.0 for separation

Design loads for the bolts:

$$P_{tu} = 1.15(1.4)(5590) = 9000 \text{ lb}$$

$$P_{su} = 1.15(1.4)(1560) = 2510 \text{ lb}$$

$$P_{ty} = 1.0(1.25)(5590) = 6990 \text{ lb}$$

$$P_{sy} = 1.0(1.25)(1560) = 1950 \text{ lb}$$

$$P_{sep} = 1.0(1.0)(5590) = 5590 \text{ lb}$$

## Accounting for Preload Uncertainty

- Given: We need to make sure threaded fastening systems function despite uncertainty in preload.
- The extent of uncertainty depends on the method of achieving preload, but there is some uncertainty with every method.
  - Torque method, turn-angle method, etc. See Sec. 7.
- There is no discrete requirement in 5020B that analyses for strength, fatigue, and separation must account for preload uncertainty, but a reasonable interpretation is that such a requirement is intended.
- What 5020B (Sec. 4.3.1) says is this:

Maximum and minimum preload calculations shall account for the preload variation associated with the method of developing initial preload, potential relaxation, creep, and the effects of maximum and minimum expected temperatures.

**To meet the intent of 5020B, we need to do strength analysis with maximum preload, separation analysis and slip analysis (when applicable) with minimum preload, and fatigue analysis (when applicable) with either maximum or minimum preload, whichever is more detrimental to fatigue life.**

## Calculation of Maximum and Minimum Preloads

NASA-STD-5020B Sec. 4.3.1

Calculated maximum preload increase caused by temperature change at maximum or minimum expected temperature

$$P_{p-\max} = P_{pi-\max} + P_{\Delta t-\max} \quad (\text{Eq. 1})$$

$$P_{p-\min} = P_{pi-\min} - P_{pr} - P_{pc} - P_{\Delta t-\min} \quad (\text{Eq. 2})$$

Maximum and minimum initial preloads

Short-term relaxation, assumed to be 5%\* of minimum initial preload if all clamped materials are metallic; otherwise based on test

Calculated maximum preload decrease (as a positive number) caused by temperature change at maximum or minimum expected temperature

Calculated maximum expected preload loss (as a positive number) from material creep, if applicable

\*Assumed relaxation greater than 5% may be prudent when stacking parts and washers or using peelable shims.

## Maximum and Minimum Initial Preloads When Installing Fasteners with Torque Control

From NASA-STD-5020B Appendix A.2:

For strength analysis and fatigue analysis  $\Rightarrow P_{pi-max} = \frac{(1+\Gamma)T_{max}}{K_{nom}D}$  (Eq. 25)

For separation analysis of separation-critical joints and for fatigue analysis (when more fatigue damage results from a low preload than a high preload)  $\Rightarrow P_{pi-min} = \frac{(1-\Gamma)T_{min}}{K_{nom}D}$  (Eq. 26a)

For separation analysis of joints that are not separation critical and for joint-slip analysis  $\Rightarrow P_{pi-min} = \left(1 - \frac{\Gamma}{\sqrt{n_f}}\right) \frac{T_{min}}{K_{nom}D}$  (Eq. 26b)

where  $P_{pi-max}$  = maximum initial preload  
 $P_{pi-min}$  = minimum initial preload  
 $\Gamma$  = preload variation  
 $T_{max}$  = maximum effective torque

$T_{min}$  = minimum effective torque  
 $n_f$  = number of fasteners in the joint  
 $K_{nom}$  = nominal nut factor  
 $D$  = nominal bolt diameter

**Effective torque** is total applied torque minus any running torque from the locking feature.

See Appendix 9A.1 herein for 5020B requirements pertaining to  $K_{nom}$  and  $\Gamma$ , along with more generic equations that apply to any method of establishing preload.

## Maximum and Minimum Effective Torques, $T_{\max}$ and $T_{\min}$

If torque is specified as some value or range “above running torque,” or if a locking feature that does not introduce a running torque is used,

$$T_{\max} = T_{s-\max} \quad (\text{Eq. 27})$$

$$T_{\min} = T_{s-\min} \quad (\text{Eq. 28})$$

where  $T_{s-\max}$  and  $T_{s-\min}$  are the maximum and minimum specified torque values

Otherwise,

$$T_{\max} = T_{s-\max} - T_{br-\min} \quad (\text{Eq. 29})$$

$$T_{\min} = T_{s-\min} - T_{L-\max} \quad (\text{Eq. 30})$$

where  $T_{br-\min}$  = minimum breakaway torque\*, as specified for the locking feature (can be assumed equal to zero)  
 $T_{L-\max}$  = maximum locking torque (running torque) specified for the locking feature

\***Breakaway torque** is the torque required to initiate relative motion between mating threads when the locking feature is fully engaged and the fastener is unseated.

## Class Problem 9-1: Calculating Maximum and Minimum Preloads

For the joint shown in Fig. 9-1 and used in class problem 4-2, given the information below:

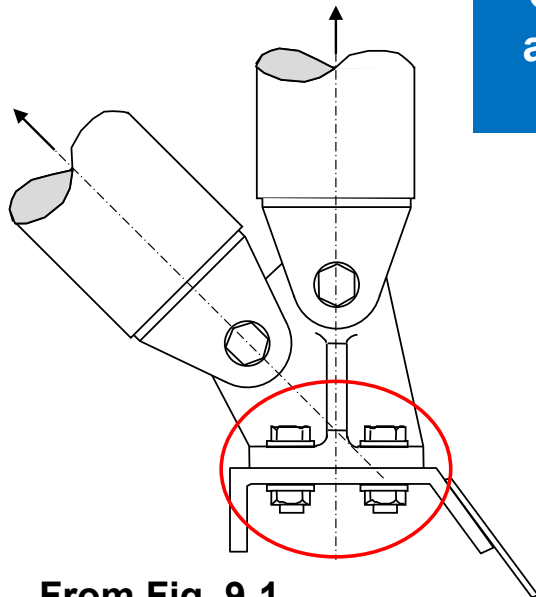

From Fig. 9-1

**Calculate maximum preload for strength analysis and minimum preload for separation analysis and joint-slip analysis.**

- The joint is not separation critical.
- Bolt diameter is 3/8”.
- Torque will be applied to the nut while the head is held, and threads and nut-to-washer surfaces will be lubricated at assembly; assume preload variation is +/-25% ( $\Gamma = 0.25$ ).
- The nominal nut factor is 0.15, based on test.
- Torque is specified as “450 to 490 in-lb above running torque”.
- No material creep is expected.
- Max. and min. expected temperatures for launch (when applied loads peak) are  $\pm 25^\circ\text{F}$  from room (assembly) temperature. (Use what we learned from Table 8-4 for a conservative estimate of temperature effects on preload.)

## Revisiting the Margin of Safety (from Sec. 1)

Recall:

The margin of safety is intended to tell us how much the applied load can increase before the design criteria are no longer satisfied.

$$MS = \frac{P'}{FS \cdot FF \cdot P_L} - 1 \quad (\text{Eq. 1.1})$$

Diagram illustrating the Margin of Safety (MS) formula (Eq. 1.1) with labels for its components:

- $P'$ : Allowable applied load
- $FS$ : Factor of safety
- $FF$ : Fitting factor
- $P_L$ : Limit load

Criterion:  $MS \geq 0$

The allowable applied load,  $P'$ , properly accounts for preload and is based on the weakest part in the fastening system, including bolt, nut or insert, and clamped parts.

## Assessment of a Fastening System's Ultimate Tensile Strength: Should Preload Be Included?

Remember: We want the margin of safety to tell us how much the applied load can go up before the criteria are no longer satisfied.

Thus, the appropriate method of calculating an ultimate margin of safety for tensile loading depends on which would happen first: separation or rupture.

If the joint would separate first, there is no preload when the fastening system ruptures; the bolt's tensile load at rupture is equal to the applied tensile load.

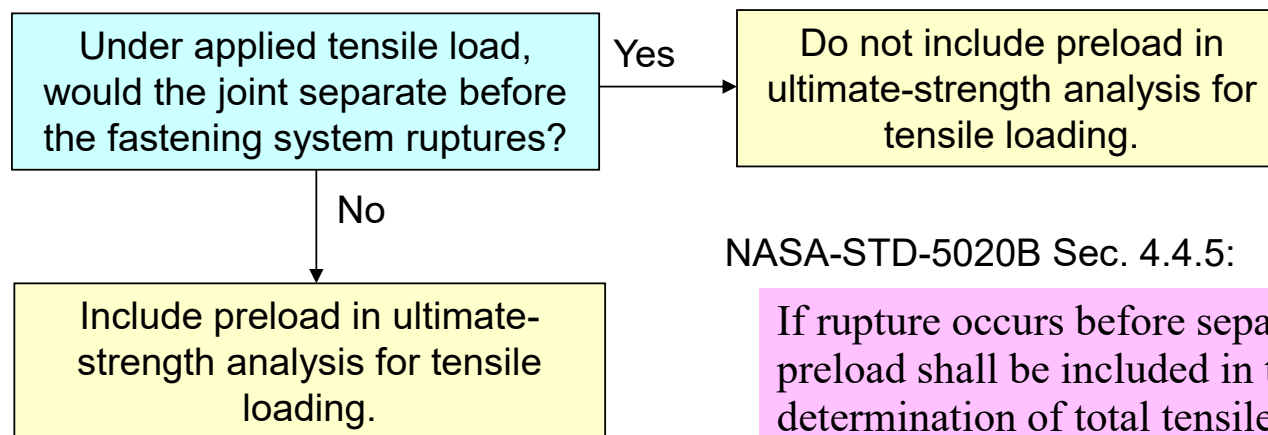

**Fig. 9-2**

NASA-STD-5020B Sec. 4.4.5:

If rupture occurs before separation, preload shall be included in the determination of total tensile load in the preloaded bolt.

## Revisiting the Linear Equation for Bolt Tensile Load Prior to Gapping

With linear theory, up to an applied tensile load that either gaps the joint or ruptures the threaded fastening system, ...

The bolt's tensile load is  $P_{tb} = P_p + n\phi P_t$  (Eq. 8.1a) (NASA-STD-5020B Eq. 8)

Preload  $\rightarrow$   $P_p$   $\leftarrow$   $P_t =$  applied tensile load per bolt

where  $\phi$  is the stiffness factor:  $\phi = \frac{k_b}{k_b + k_c}$  (Eq. 8.1b) (5020B Eq. 9)

Bolt stiffness  $\rightarrow$   $k_b$   $\leftarrow$  Stiffness of clamped joint members ("clamp stiffness")  $k_c$

and  $n$  is the load-introduction factor (a.k.a. loading-plane factor).

## Allowable Applied Load with Linear Theory if Rupture Is Predicted to Occur Before Separation

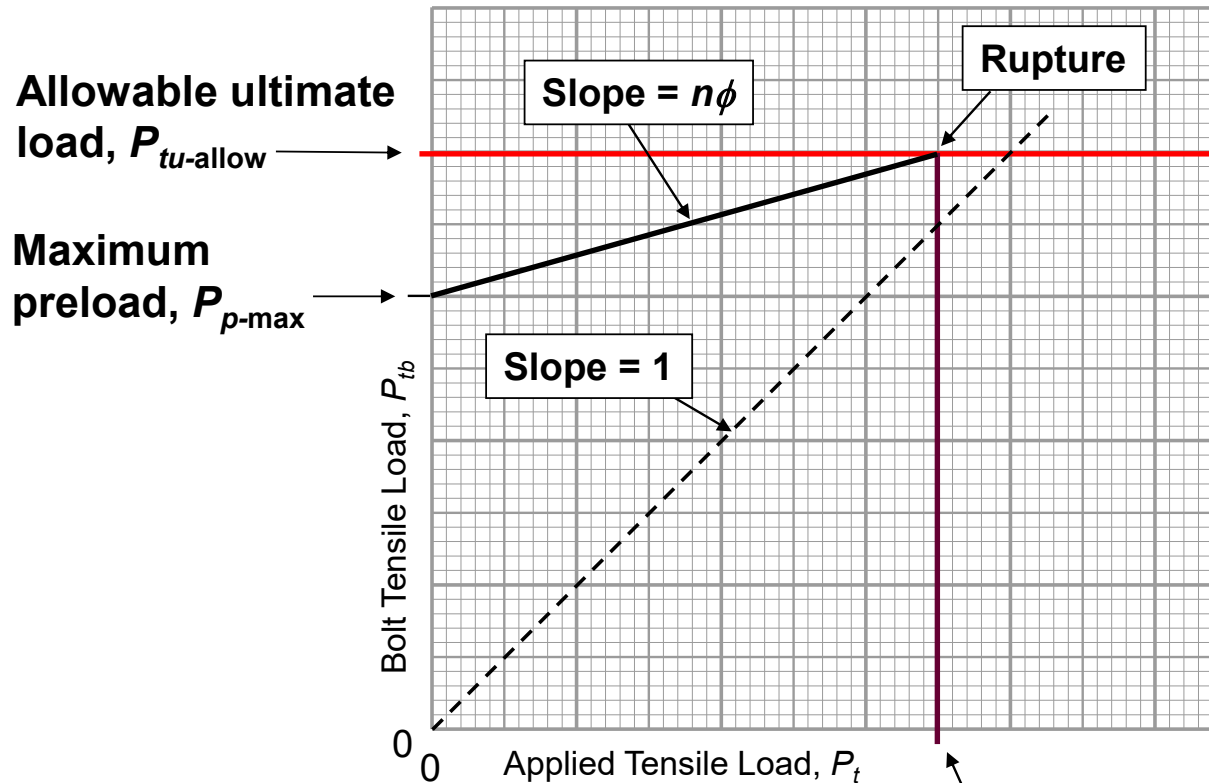

**Fig. 9-3**  
(similar to  
NASA-STD-5020B  
Fig. 15)

$$\text{Allowable applied ultimate tensile load} = P'_{tu} = \frac{1}{n\phi} (P_{tu\text{-allow}} - P_{p\text{-max}}) \quad (\text{Eq. 10})$$

## Separation Before Rupture with Linear Theory

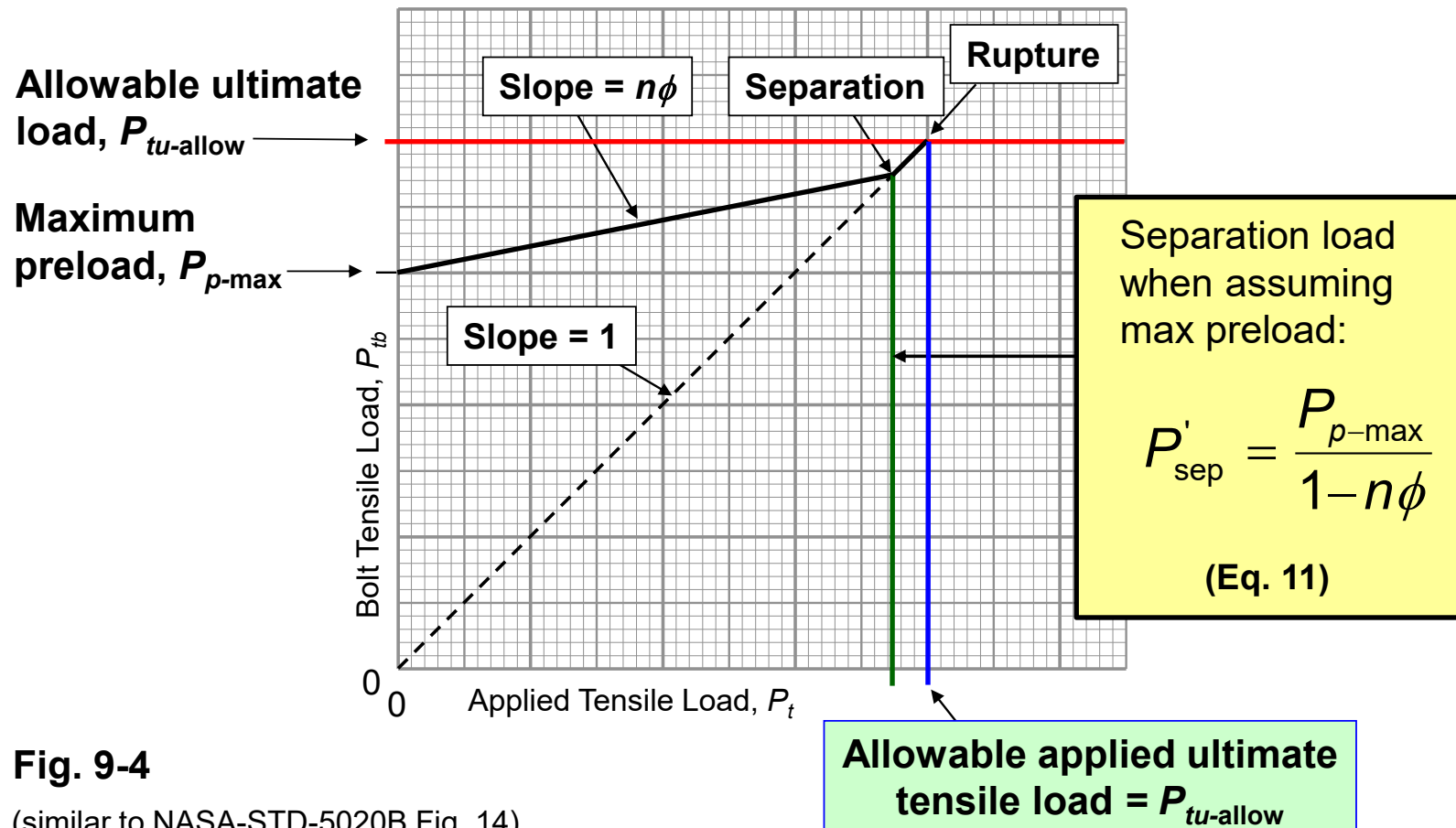

**Fig. 9-4**

(similar to NASA-STD-5020B Fig. 14)

## Ultimate Margin of Safety for Applied Tensile Loading

Review: With linear theory and preload set at maximum ( $P_{p-max}$ ) ...  
if rupture occurs before separation, the applied tensile load that causes the bolt load to equal the allowable ultimate tensile load is

$$P'_{tu} = \frac{1}{n\phi} (P_{tu-allow} - P_{p-max}) \quad (\text{Eq. 10})$$

whereas the separation load when at max preload is  $P'_{sep} = \frac{P_{p-max}}{1-n\phi}$  (Eq. 11)

If  $P'_{sep} < P'_{tu}$ , then separation would occur before rupture, Eq. 10 is not valid, and the margin of safety is

$$MS_u = \frac{P_{tu-allow}}{P_{tu}} - 1 \quad (\text{Eq. 6})$$

If  $P'_{sep} > P'_{tu}$ , then separation might not occur prior to rupture, Eq. 11 is not valid, and the margin of safety is

$$MS_u = \frac{P'_{tu}}{P_{tu}} - 1 \quad (\text{Eq. 7})$$

where  $P_{tu} = FF_u \cdot FS_u \cdot P_{tL}$

## Rupture Before Separation

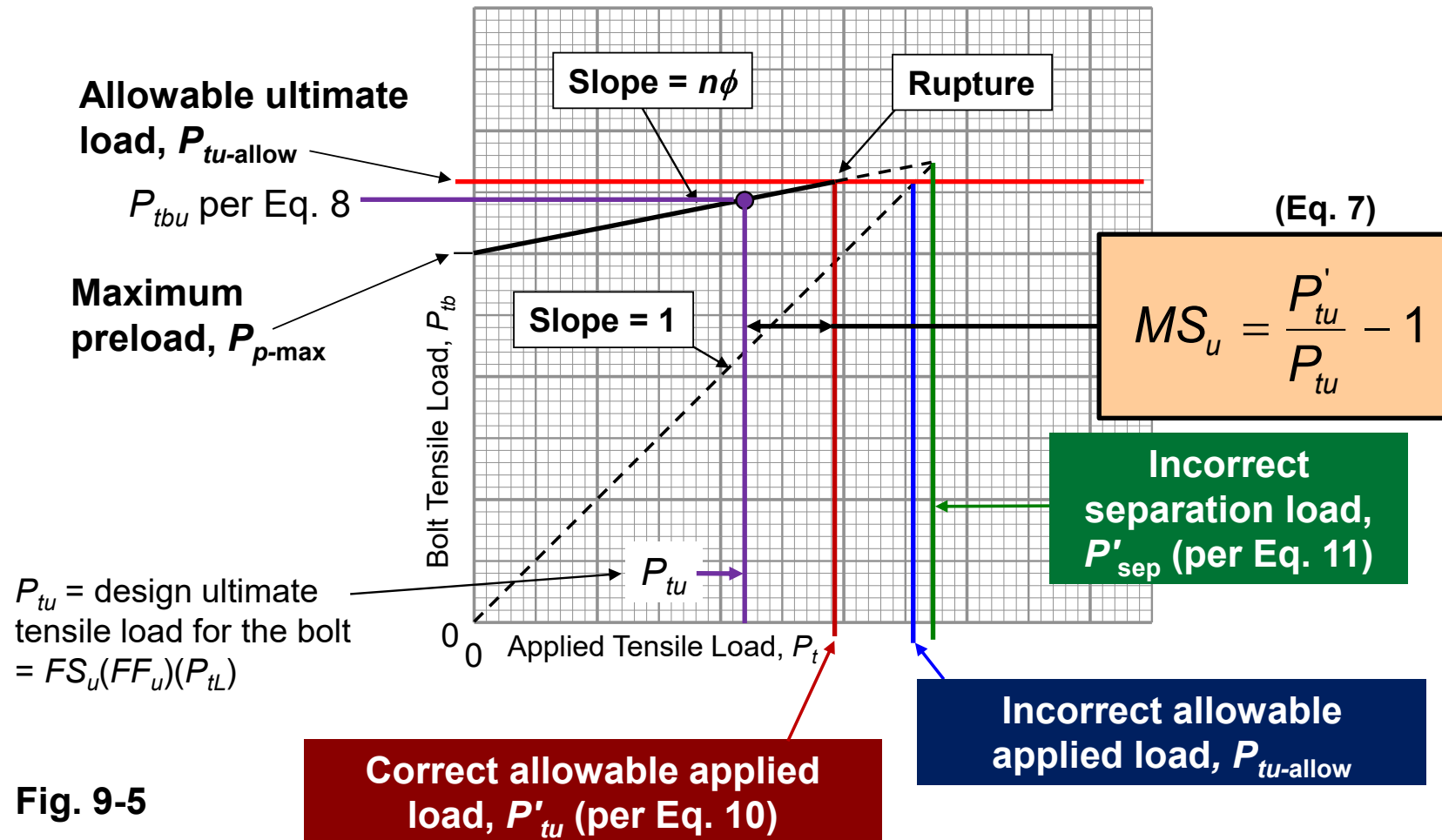

Fig. 9-5

## Separation Before Rupture

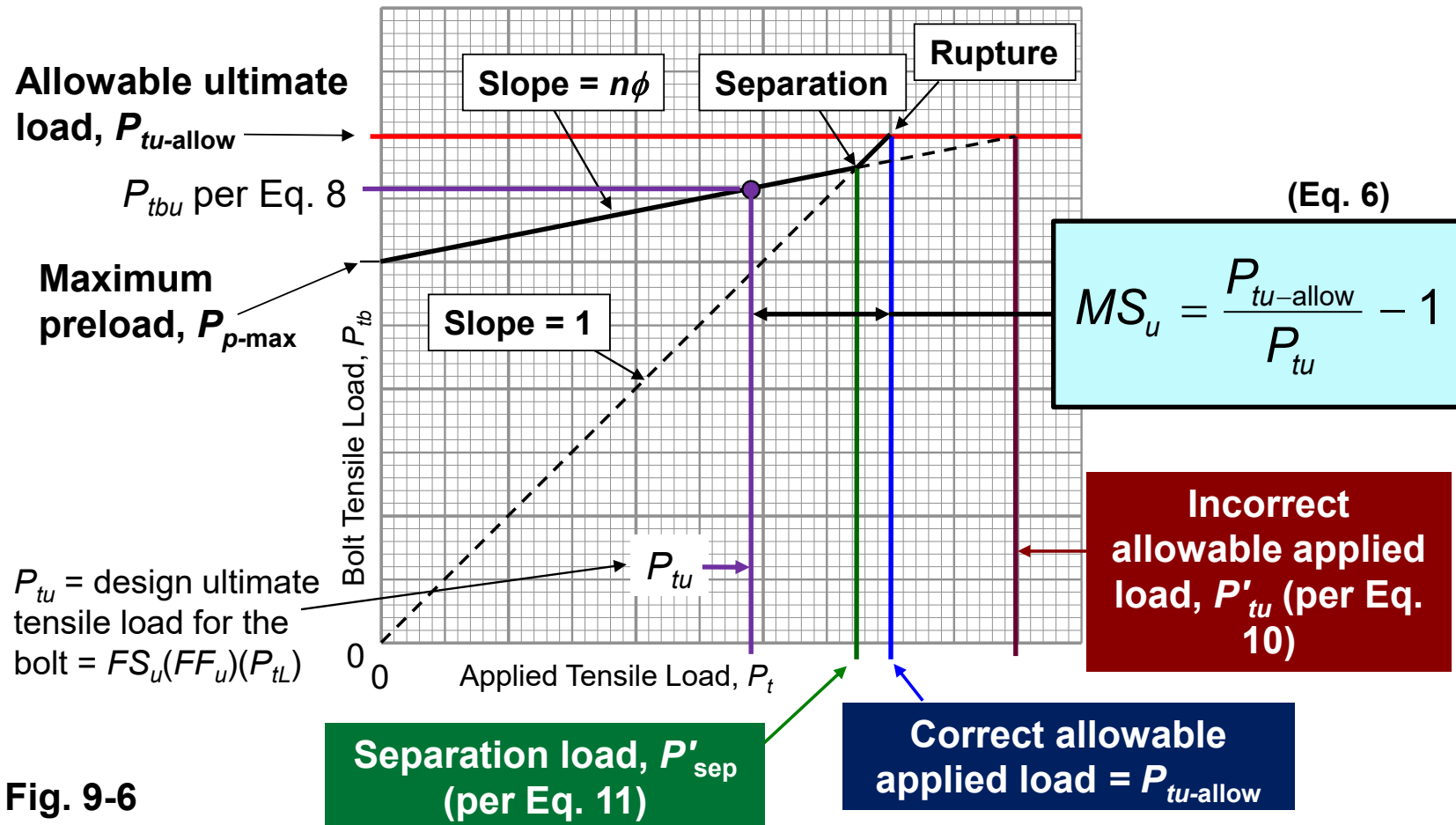

Fig. 9-6

### Example Problem 9-a: Ultimate Margin of Safety for Tensile Loading

Given:

$$P_{tu\text{-allow}} = 8200 \text{ lb}$$

$$P_{p\text{-max}} = 6400 \text{ lb}$$

$$n\phi = 0.25$$

$$FS_u = 1.4, FF_u = 1.15$$

$$P_{tL} = 4200 \text{ lb}$$

$$P_{tu} = 1.15(1.4)(4200) = 6760 \text{ lb}$$

Assuming rupture before separation, the applied tensile load that causes the bolt load to equal the allowable ultimate tensile load for the fastening system is

$$P'_{tu} = \frac{1}{0.25}(8200 - 6400) = 7200 \text{ lb}$$

Whereas, if separation occurs before rupture, the load that causes separation is

$$P'_{sep} = \frac{6400}{1 - 0.25} = 8530 \text{ lb}$$

Because  $P'_{sep} > P'_{tu}$ , rupture may occur before separation, and the ultimate margin of safety for tensile loading is per Eq. 7:

$$MS_u = \frac{7200}{6760} - 1 = +0.06$$

## Does the Analysis Need to be This Complicated?

### No. Let's simplify ...

Now that you understand the significance of separation before rupture, recognize that there's no need to calculate the separation load at maximum preload in order to assess ultimate tensile strength. Simply use the lesser of  $P'_{tu}$  from Eq. 10 and  $P_{tu\text{-allow}}$  as the allowable applied load in the margin of safety equation.

But we can simplify further:

**For many designs, it is not necessary to calculate  $\phi$  and  $n$  in order to compute an ultimate margin of safety for tension in the fastening system.**

**This is the case when we can recognize without such calculations that the joint would separate before the fastening system ruptures.**

**Let's draw some conclusions in this regard based on what we learned in Sec. 8 ...**

## What We Learned in Section 8

For a preloaded joint with aluminum joint members and a steel (or A-286) bolt, with  $e/D \geq 1.5$  for all clamped parts (other than washers) ...

- Spreadsheets (Tables 8-2 and 8-3): Typical joint, with washers and variable pad thicknesses:
  - Up until the joint separates, based on linear theory, the tensile load in the bolt increases by no more than 20% of the applied tensile load ( $n\phi \leq 0.20$ ).
- Example problem 8-c: Extreme joint with thick spacer to make the loading-introduction factor equal to 0.9:
  - Up until the joint separates, based on linear theory, the tensile load in the bolt increases by no more than 25% of the applied tensile load ( $n\phi \leq 0.25$ ).
  - This conclusion is drawn also in NASA-STD-5020B Appendix A.5, based on the analysis referred to in example problem 8-c herein.
- Effect of ductile failure:
  - If the threaded fastening system exhibits ductile failure, once yielding begins the percentage of applied load going into the bolt on top of preload drops significantly, making separation before rupture more likely.

## Separation Before Rupture with the Linear Model

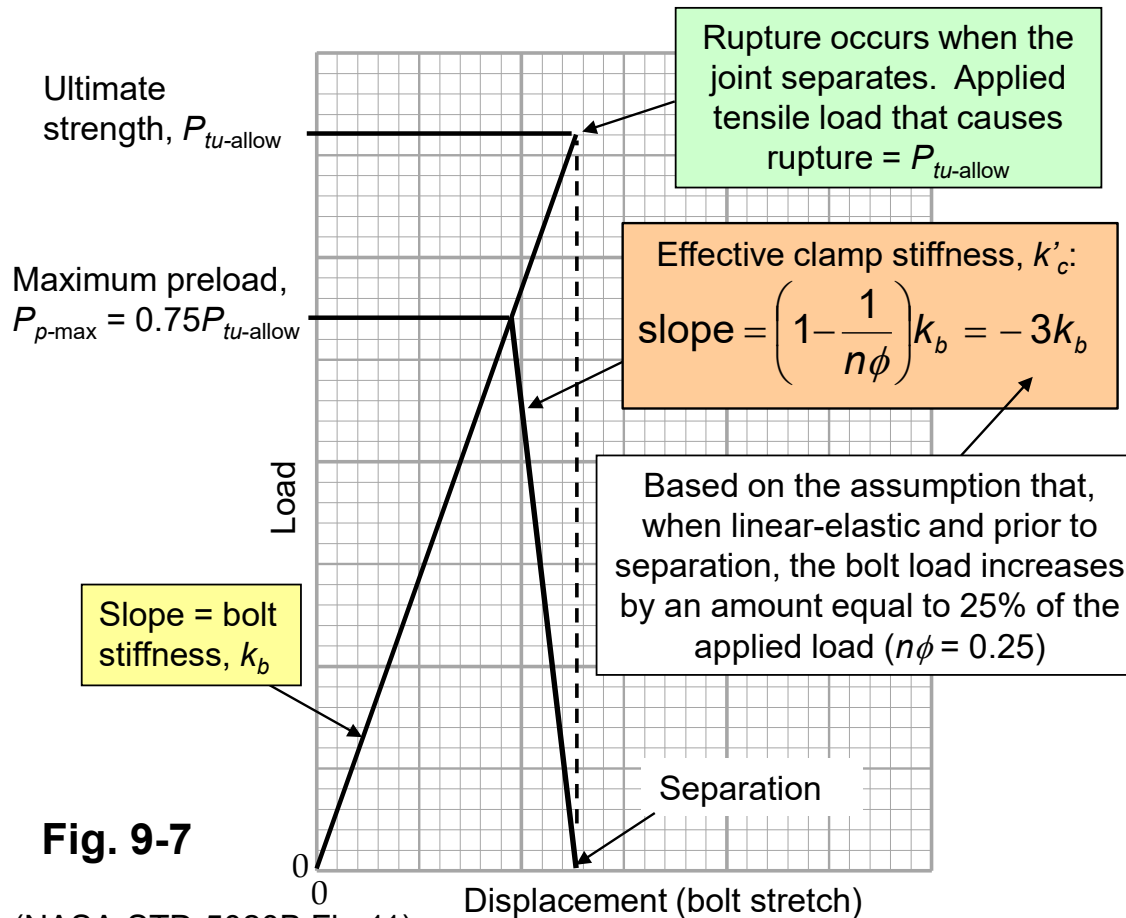

**Fig. 9-7**

(NASA-STD-5020B Fig.11)

Based on the conclusions from the previous page, ...

**For a preloaded joint with a steel bolt and all clamped parts other than washers made of aluminum, with  $e/D \geq 1.5$ , even if failure is perfectly brittle the joint would separate under applied tensile loading before rupture if preload does not exceed 75% of the fastening system's ultimate strength.**

## Separation Before Rupture for a Ductile Fastening System

Let's assume the maximum preload is equal to 85% of the ultimate tensile strength of the fastening system.

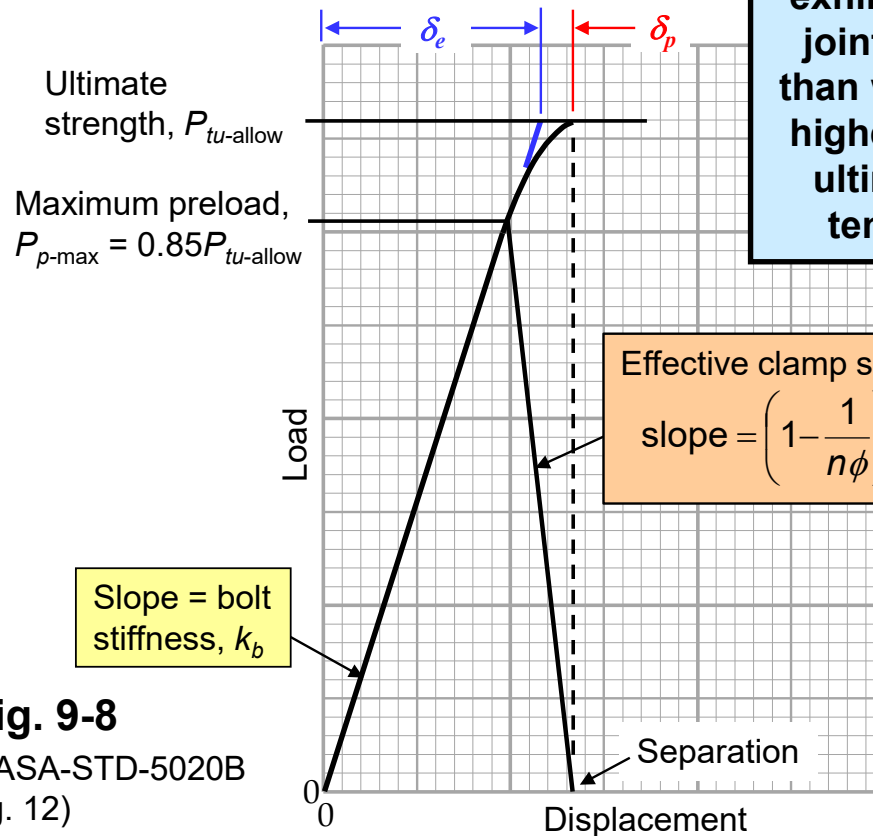

**Conclusion:** If the fastening system exhibits ductility of at least  $\delta_p/\delta_e > 0.133$ , a joint with aluminum clamped parts other than washers and a steel bolt preloaded no higher than 85% of the fastening system's ultimate strength would separate under tensile loading before rupture occurs.

To account for uncertainty\*, the original 5020 team established a ductility limit of 0.25 instead of 0.133 to rely on this conclusion.

**Fig. 9-8**  
(NASA-STD-5020B Fig. 12)

\*Because of variation, not all fastening systems of a given type exhibit the same plastic deformation.

## Proof-of-Concept Testing by NASA-STD-5020 Team

- Two diameters ( $D$ ) of fasteners tested:
  - #10 NAS1351, 160 ksi A-286, from mixed lots
  - 3/8"-dia NAS1956C28, 180 ksi A-286, all from the same lot
- Spacer diameter,  $d_s$ , was  $3D$
- 5 specimens tested with no preload, 5 tested with extremely high preload (fastener yielded during assembly), lubricated to minimize nut factor

Test conducted at NASA Goddard Research Center, May – July, 2009 (Ref. 50)

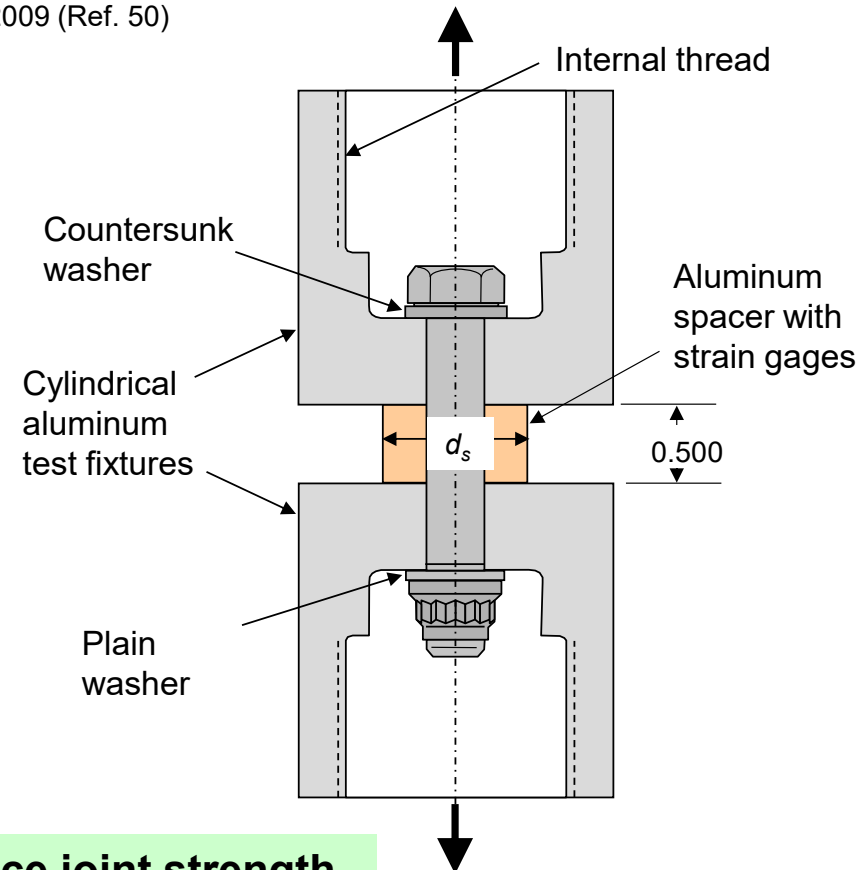

### Results—average ultimate strength for 3/8" bolts:

Not preloaded: 19,813 lb  
Preloaded: 19,975 lb

### Conclusion: Preload did not reduce joint strength.

(The #10 screws, which were from mixed lots, showed too much scatter to draw meaningful conclusions.)

## Identifying Whether Rupture Can Occur Before Separation

**Fig. 9-9**

(adapted from NASA-STD-5020 basic release\*, Fig. 5)

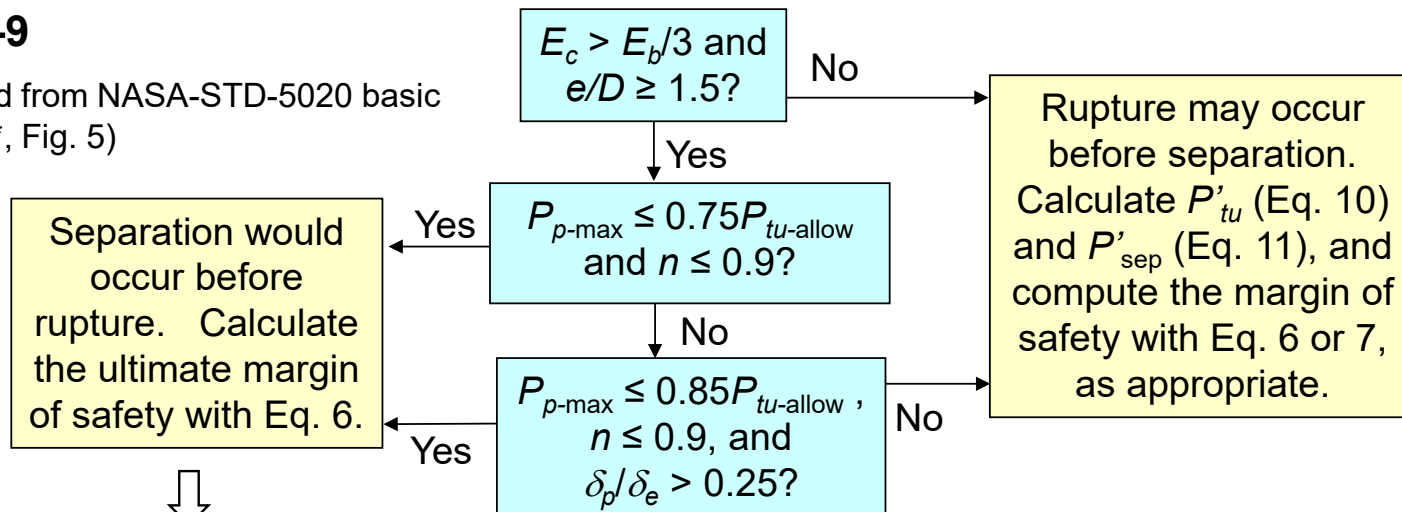

$$MS_u = \frac{P_{tu-allow}}{P_{tu}} - 1 \quad (\text{Eq. 6})$$

where  $P_{tu} = FF_u \cdot FS_u \cdot P_{tL}$

where

- $E_c$  = elastic modulus of clamped material
- $E_b$  = elastic modulus of bolt material
- $e$  = shortest in-plane distance from center of hole to edge of any clamped part other than washers
- $D$  = bolt nominal diameter
- $P_{p-max}$  = maximum preload
- $P_{tu-allow}$  = allowable ultimate tensile load for the threaded fastening system
- $n$  = load-introduction factor
- $\delta_p$  = plastic displacement at rupture
- $\delta_e$  = elastic displacement at rupture

\*This flow diagram was revised for 5020A (Fig. 8), but the revision contains errors, which were partially—but not fully—corrected in 5020B. I recommend using the above version, which refers to the correct equations in 5020B.

## Class Problem 9-2: Ultimate Margin of Safety for Bolt Tension

For the joint used in class problem 9-1, as defined on p. 9-6,

**Calculate the ultimate margin of safety for bolt tension by itself.  
(You'll assess interaction of tension and shear in a later problem.)**

- Given:
- Maximum preload is 11,070 lb
  - Aluminum joint members, with no shims or other non-load-bearing spacers
  - Minimum edge-distance ratio for joint members,  $e/D \geq 1.5$ .
  - The bolt and the nut have the same specified minimum strength:  
 $P_{tu\text{-allow}} = 15,200$  lb
  - Design ultimate tensile load,  $P_{tu} = 9000$  lb (includes ultimate factor of safety and fitting factor).

## The Problem with Linear Theory for Separation Analysis

- The actual separation (full-gapping) load is difficult to predict, even if preload is known.
- The total bolt load prior to separation also is difficult to predict.
- Traditional methods of calculating  $n$  and  $\phi$  are intentionally on the safe side of uncertainty when assessing the bolt,
  - which means they are on the unsafe side when assessing separation.
- The actual behavior of a joint is nonlinear.
  - The entire joint does not separate uniformly; separation is gradual.
    - Think of a gradually receding compression circle as applied load increases.
    - The extent of nonlinearity depends on the joint's geometry.
  - Also, bolt stiffness decreases nonlinearly if the bolt stress exceeds the material's proportional limit.

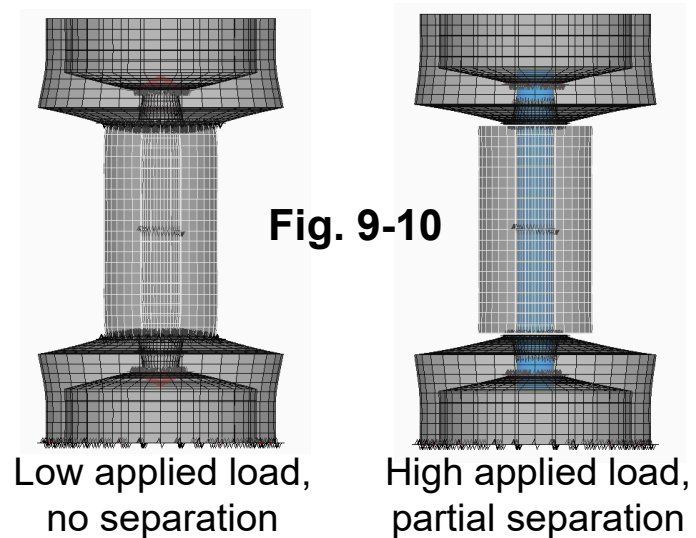

## Actual Behavior Compared with the Linear Model

Intended to conservatively estimate bolt load given uncertain actual behavior

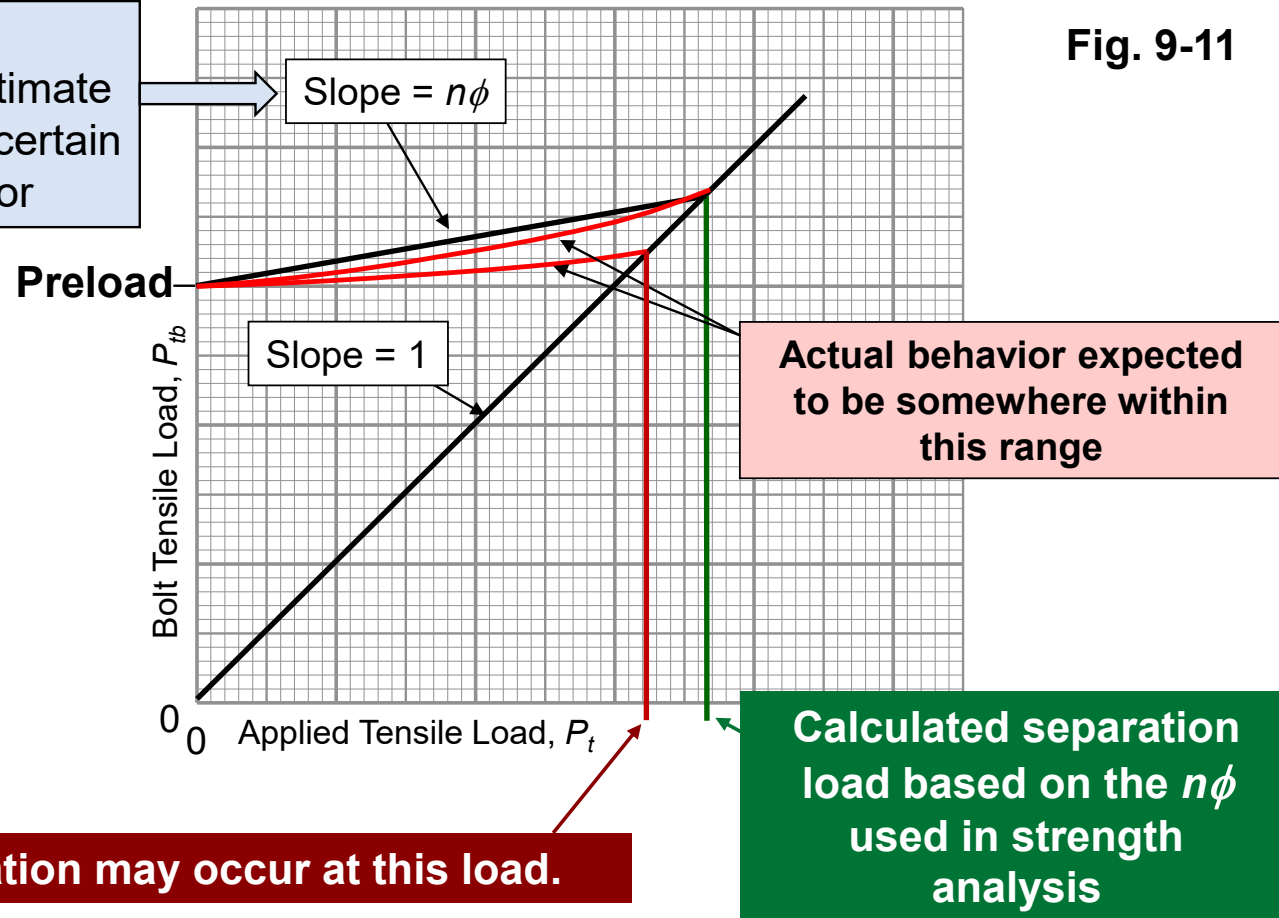

Fig. 9-11

## A Conservative Assumption for Separation Analysis (other than for joints that must maintain a seal)

Assumption: Clamp stiffness is infinite.

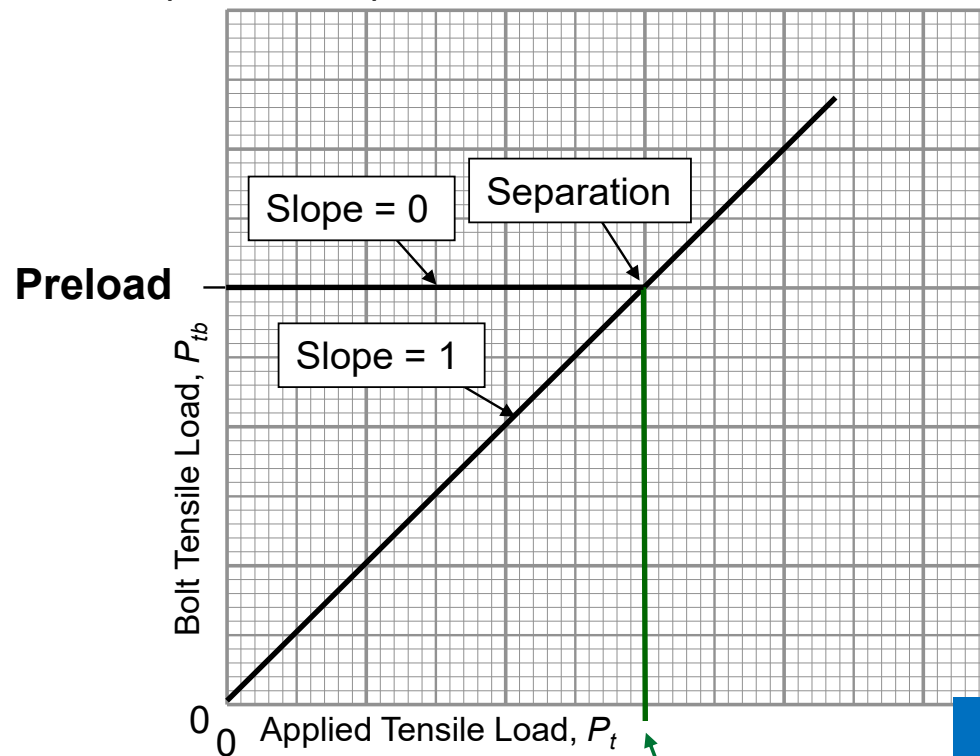

Fig. 9-12

Separation load equal to preload

Margin of safety for separation:

$$MS_{sep} = \frac{P_{p-min}}{P_{sep}} - 1$$

(Eq. 19)

Design separation load,  
 $P_{sep} = FF_{sep} \cdot FS_{sep} \cdot P_{tL}$

**NASA-STD-5020B suggests—but does not require—this method for separation analysis.**

**I'll go a step further and recommend it! When you want to remove excess conservatism, use detailed FEA.**

## Class Problem 9-3: Separation Margin of Safety

For the joint used in class problem 9-1, as defined on p. 9-6:

**Calculate the separation margin of safety based on the assumption that the clamp stiffness is infinite.**

- Given:
- The joint is not separation critical. The separation factor of safety,  $FS_{sep}$ , is 1.0. The separation fitting factor,  $FF_{sep}$ , also is 1.0.
  - Design separation load per bolt,  $P_{sep} = 5590$  lb (limit bolt tension,  $P_{tL}$ , multiplied by 1.0  $FF_{sep}$  and 1.0  $FS_{sep}$ ).
  - Minimum preload is 6470 lb (from class problem 9-1).

## Fastening System Yield Strength

**If yielding is not detrimental, there is no need to calculate a yield margin of safety.**

The original NASA-STD-5020 analysis team agreed on the above, and it's acknowledged in Sec. 4.4.2 of 5020B.

**So we need to be able to recognize situations in which yielding of materials within the fastening system is detrimental.**

## Fastening System Yield Strength Analysis

Per NASA-STD-5020B Sec. 4.4.2,

*The assessment for yield design loads will address all elements of the threaded fastening system, including the fastener, the internally threaded part such as a nut or an insert, and the clamped parts.*

But remember, yield strength analysis is required only if yielding is detrimental.

So let's start by recognizing that, for a common bolted joint, yielding of the material making up the nut or threaded insert is not detrimental unless it reduces the ultimate strength of the system. We've already addressed that concern with the ultimate strength criterion by simply assessing the minimum specified strength of the nut or the insert.

Yielding in internal threads is actually beneficial because it spreads loads to other threads and reduces tensile stress concentrations in the bolt.

Can there be exceptions, joints for which yielding of nut or insert material is detrimental? Possibly. That's for you to decide, and that's why the standard says what it does.

**A more common concern is yielding over the bolt's tensile stress area (referred to as *bolt yielding* or *fastener yielding*).**

## Bolt Yielding in Tension

If bolt yielding is detrimental, we can calculate an allowable tensile yield load as ...

$$P_{ty\text{-allow}} = \left( \frac{F_{ty}}{F_{tu}} \right) P_{tu\text{-allow}} \quad (\text{Eq. 18})$$

↖ Allowable yield tensile stress for material  
↖ Allowable ultimate tensile stress for material

Note: This equation applies only when  $P_{tu\text{-allow}}$  is the minimum bolt strength based on the tensile stress area, not the strength associated with bolt-head failure or thread stripping.

Allowable stresses (ksi) for selected bolt materials:

	A-286 AMS 5853B	A-286 AMS 5726C	Inconel AMS 5962A	300-series CRES for cap screws*
$F_{tu}$	160	200	220	80
$F_{ty}$	120	180	200	30

\*for sizes up to 5/8" diameter, per FF-S-86F (Ref. 15)

**What could be detrimental about bolt yielding? Let's brainstorm ...**

## Is Bolt Yielding Under Design Yield Loads Detrimental?

Fastener yielding under the design yield tensile load may be detrimental if ...

- yielding causes the joint to separate under the design separation load (see upcoming pages), or
- yielding causes the joint to suffer detrimental slip under the design yield shear load, or
- some other design-specific reason exists for why fastener yielding is detrimental.
  - not the case for most joints,
  - but you have to understand any unique aspects of your design!

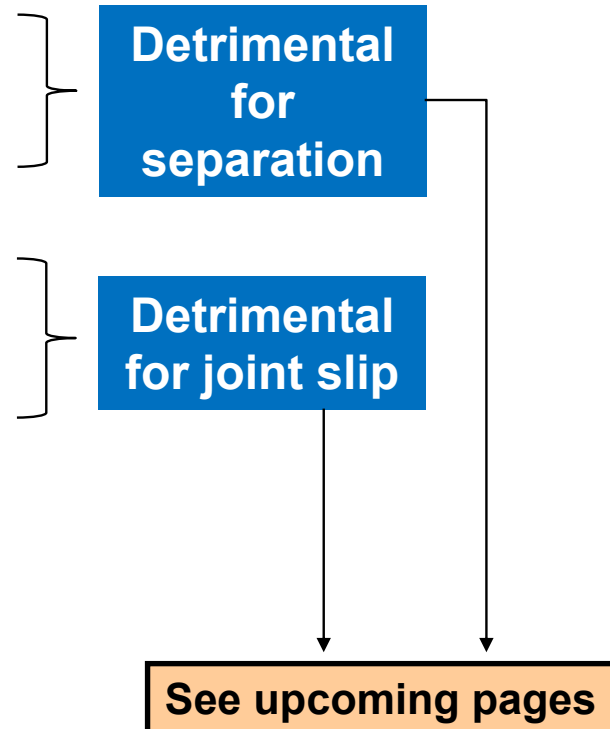

## Effect of Bolt Yielding on the Separation Load

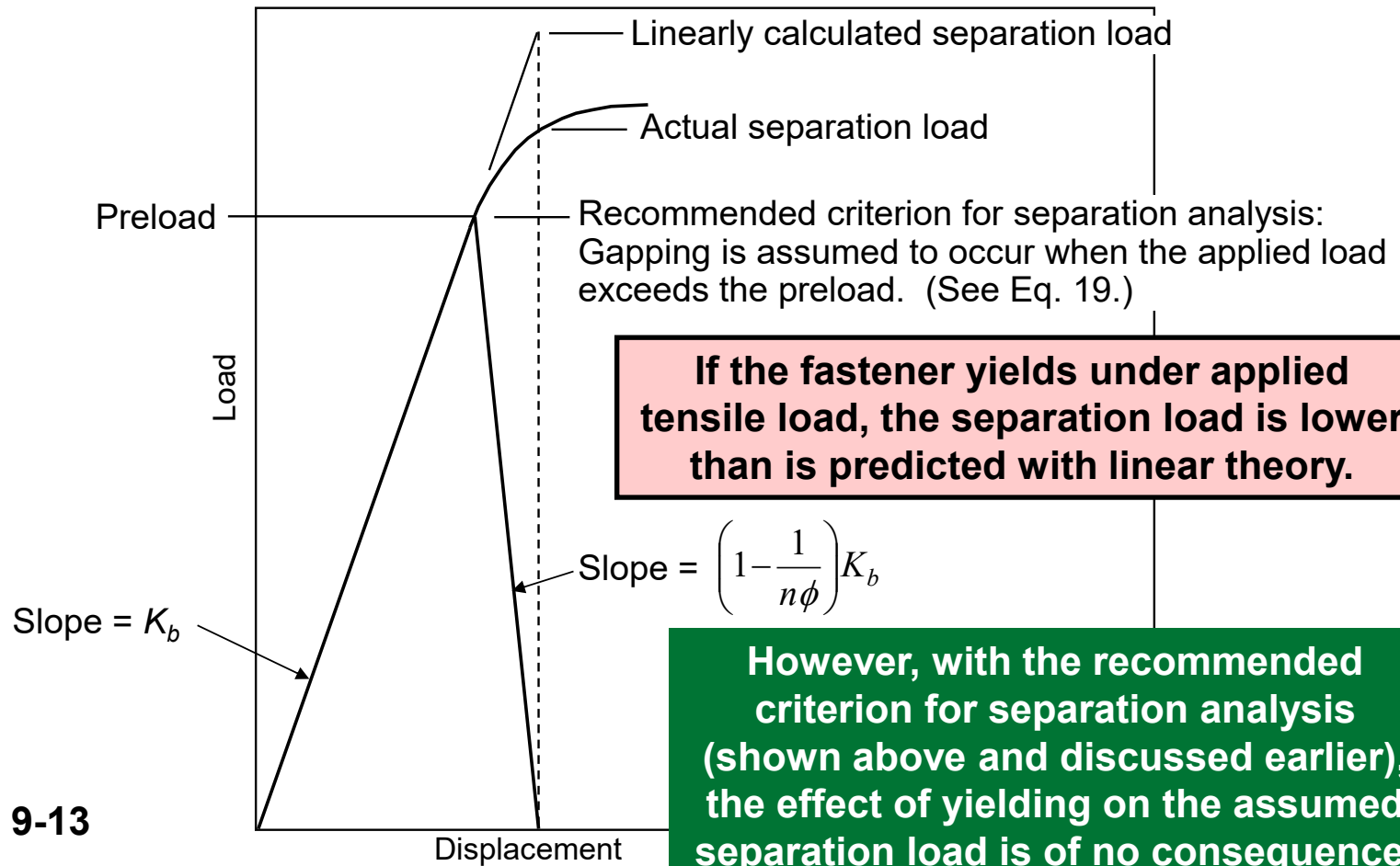

**Fig. 9-13**

(similar to NASA-STD-5020B Fig. 18)

## The Effect of Yielding Prior to Separation

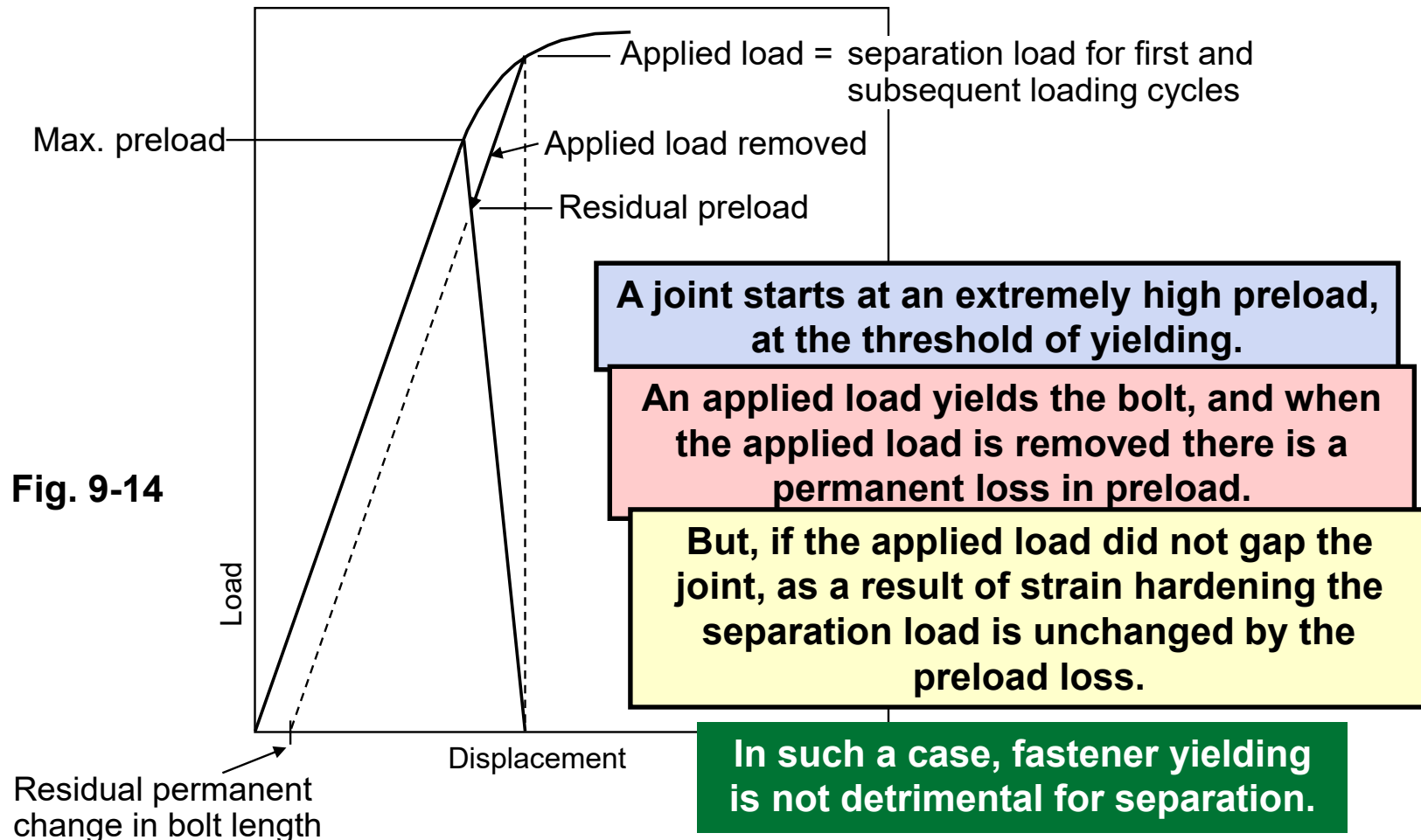

## Even Bolt Yielding that Occurs When the Joint is Separated Is Not Normally Detrimental for Separation when Using Torque Control

Assume the bolt starts at a high maximum preload, and the design yield load causes the joint to separate and the bolt to yield:

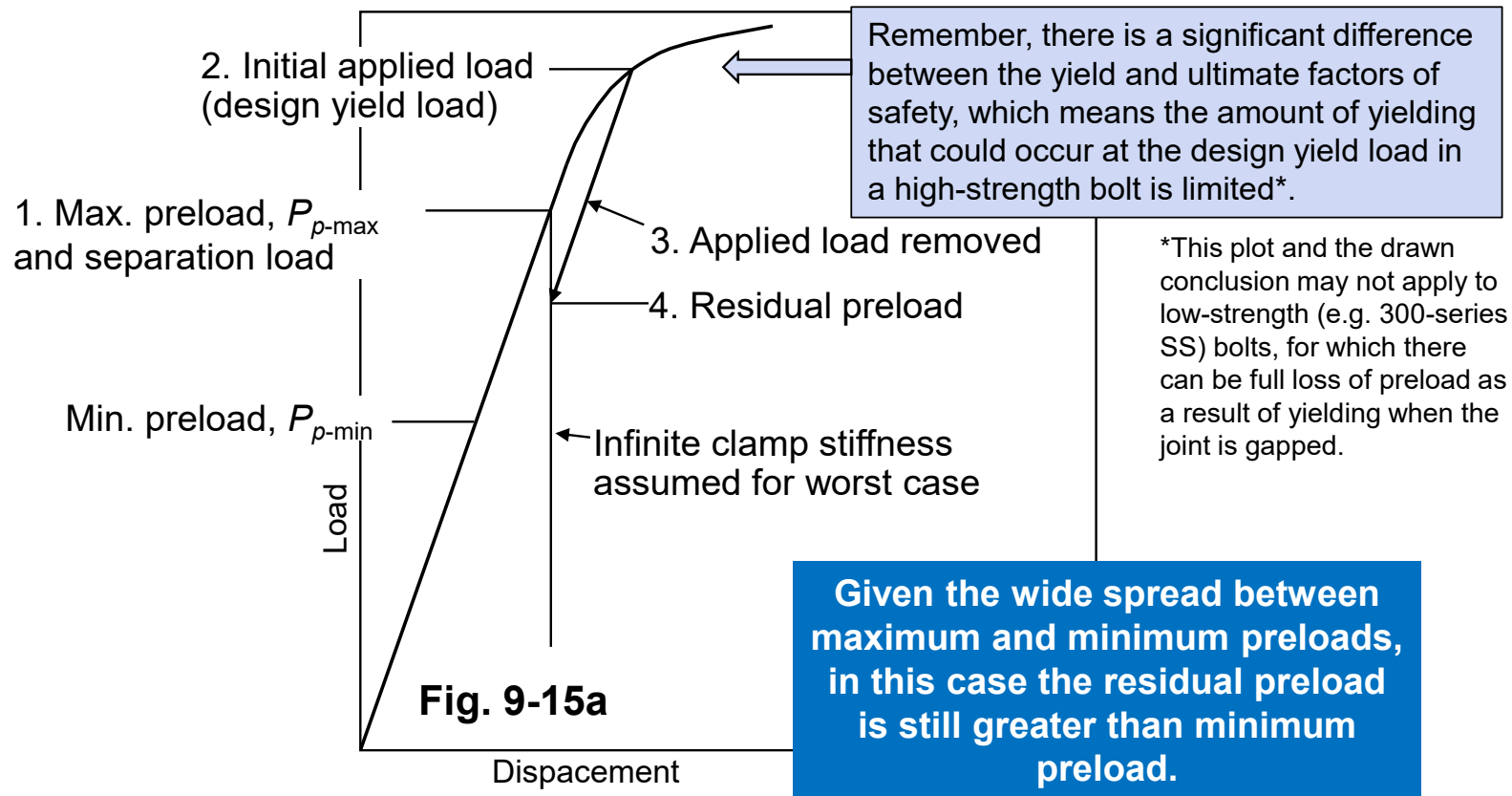
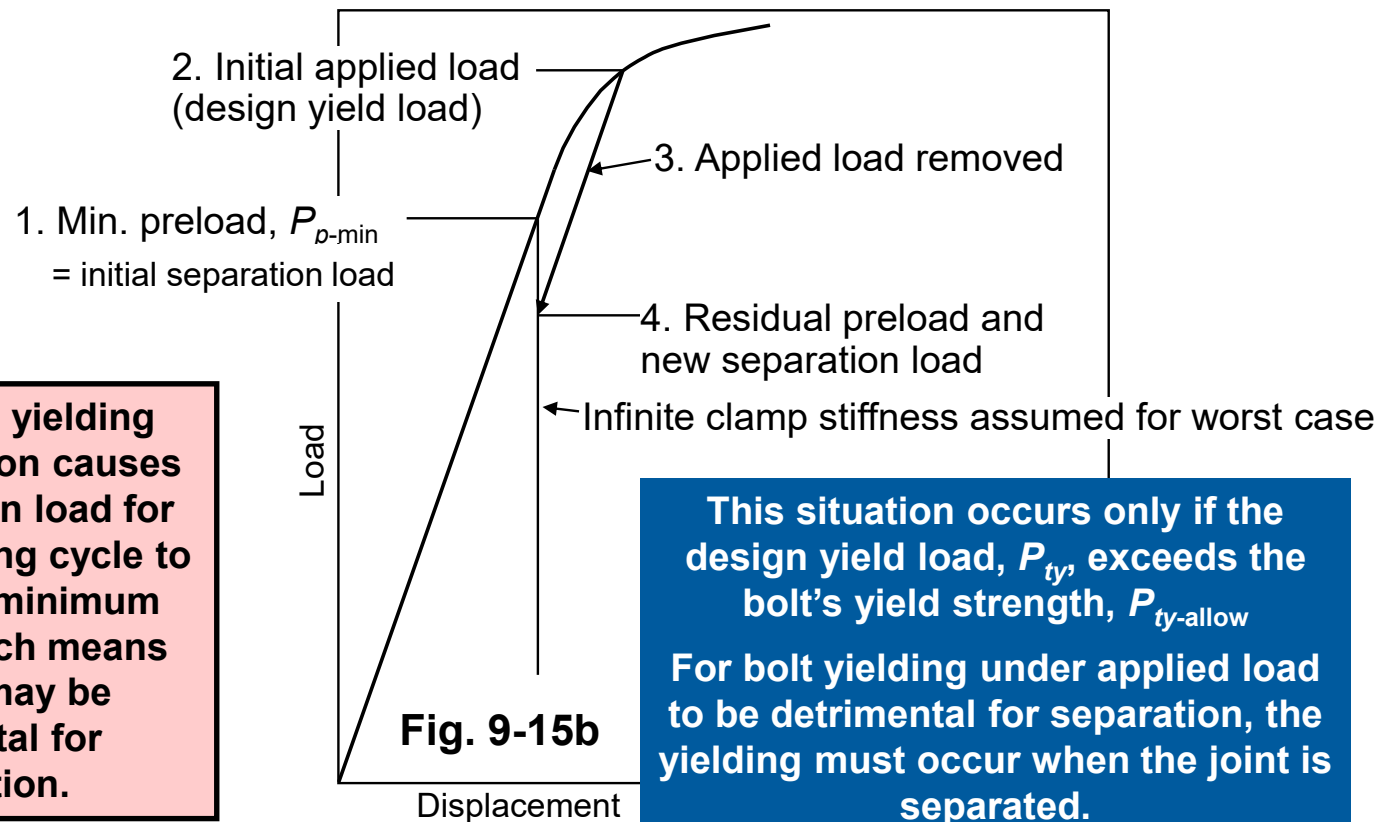

Fig. 9-15a

## Bolt Yielding that Occurs When the Joint is Separated Can Be Detrimental for Separation If Preload Was Controlled Accurately

Assume the bolt starts at a high minimum preload, established with a method more accurate than torque control, and the design yield load causes the joint to separate and the bolt to yield:



In this case, yielding after separation causes the separation load for the next loading cycle to drop below minimum preload, which means yielding may be detrimental for separation.

This situation occurs only if the design yield load,  $P_{ty}$ , exceeds the bolt's yield strength,  $P_{ty-allow}$

For bolt yielding under applied load to be detrimental for separation, the yielding must occur when the joint is separated.

## Let's Repeat the Observation on the Previous Page

**For bolt yielding under applied tensile load to be detrimental for separation, the yielding must occur when the joint is separated.**

Our separation criteria ensure the joint will not separate at the design separation load, but the design yield load may be higher than the design separation load because of different factors of safety and fitting factors.

And, drawing upon an earlier observation:

**Bolt yielding that occurs when the joint is separated is detrimental for separation only if the residual preload is less than the originally calculated minimum preload—which typically would not be the case when using torque control to preload the joint, given preload variation.**

## Is Bolt Yielding Detrimental for Joint Slip?

- The question of whether bolt yielding is detrimental for joint slip arises, of course, only if joint slip is detrimental and you are counting on friction to prevent joint slip.
- Unlike the case for separation concerns, any yielding under applied load that causes the residual preload, once the applied load is removed, to be less than the calculated minimum preload can be detrimental for joint slip.
  - Example: The bolt yields under applied tension, and a later load case of applied shear causes the joint to slip.
- ➔ – But this situation is highly unlikely when using torque control to obtain preload because of the wide spread between maximum preload (when yielding is of potential concern) and minimum preload. (See Fig. 9-14a.)
- Graphical methods can be used to identify the bounds within which bolt yielding under applied load is not detrimental.

**Bottom line: If you can't convince yourself and other stakeholders that bolt yielding is not detrimental, then assume it is detrimental, and calculate a yield margin of safety. (See next page.)**

**But, when weight is truly critical, you should not let a yield margin of safety drive the design if yielding is not detrimental.**

## Calculating a Yield Margin of Safety When Bolt Yielding is Detrimental

If fastener yielding is (or may be) detrimental, NASA-STD-5020B says one way to calculate a yield margin of safety is with the following process:

- a. Calculate the applied tensile load that would cause the bolt load to equal  $P_{ty\text{-allow}}$ , with the assumption of maximum preload,  $P_{p\text{-max}}$ , and no separation:

$$P'_{ty} = \frac{1}{n\phi} (P_{ty\text{-allow}} - P_{p\text{-max}}) \quad (\text{Eq. 17})$$

- b. Compare  $P'_{ty}$  to the calculated separation load,  $P'_{sep}$ , when at maximum preload (Eq. 11):

If  $P'_{ty} < P'_{sep}$ , calculate the yield margin of safety as

$$MS_y = \frac{P'_{ty}}{P_{ty}} - 1 \quad (\text{Eq. 16})$$

where  $P_{ty} = FF_y \cdot FS_y \cdot P_{tL}$

If  $P'_{ty} > P'_{sep}$ , calculate the yield margin of safety as

$$MS_y = \frac{P_{ty\text{-allow}}}{P_{ty}} - 1 \quad (\text{Eq. 15})$$

**Note:** Although not stated in 5020B, if separation is the only potential detriment of bolt yielding, then only Eq. 15 applies because yielding must occur when the joint is separated to be detrimental for separation, as discussed earlier.

## Class Problem 9-4: Assessing Bolt Yield

For the joint used in class problem 9-1, as defined on p. 9-6:

**Address bolt yielding from applied tensile load.**

Given: • The bolt material's allowable tensile yield stress,  $F_{ty}$ , is 120 ksi, and the allowable ultimate tensile stress,  $F_{tu}$ , is 160 ksi.

From class  
problem 9-1

- Maximum preload,  $P_{p-max}$ , is 11,070 lb, minimum preload,  $P_{p-min}$ , is 6470 lb.
- Minimum initial preload,  $P_{pi-min} = 7000$  lb.
- Maximum change in preload for temperature change,  $P_{\Delta t-max} = 180$  lb.
- Design yield tensile load,  $P_{ty} = 6990$  lb (from p. 9-6).
- Design separation load,  $P_{sep} = 5590$  lb (from p. 9-6).

## Shear Loading: Friction as a Load Path

- For the most dependable shear joint with threaded fasteners in clearance holes, load is carried by a dedicated feature such as a shear pin or by friction rather than by shear through the fasteners.
  - This is especially true for joints under cyclic, reversed shear loading.
  - Otherwise, the joint would slip back and forth in the clearance holes,
    - leading to nonlinear structural behavior, potential fretting, loss of preload, and potential shock from impact.
- NASA-STD-5020B Sec. 4.4.6 allows use of beneficial friction in analysis for alignment, yield strength, fatigue, and fracture mechanics,
  - using a conservative, low coefficient of friction in absence of approved test data (addressed in the upcoming topic of joint slip).
- But not for ultimate strength. Rationale:
  - At rupture, there is little or no friction load because local yielding causes preload to relax. Tests show that ultimate shear strength is the same, regardless of whether the joint is preloaded. (See next page.)
  - The consequence of catastrophic failure is too high for us to count on having the preload we've calculated.

## Does Preload Reduce the Strength of a Shear Joint?

- Hypothesis: With fasteners made of ductile materials, preload neither increases nor decreases the ultimate strength of a shear joint.
  - Yielding causes preload to relax prior to rupture.
- Tests at NASA/Goddard in August 2009 (Ref. 50) substantiated this hypothesis:
  - Double shear, steel plates, threads not in shear plane, dry-film molybdenum disulphide between plates to minimize friction
  - 3/8" 180-ksi A286 through-bolts with nuts in holes sized at 0.386 +0.007/-0.002"
  - Tests performed to rupture
    - 5 specimens without preload
    - 5 specimens with extremely high preload (above yield)

See NASA-STD-5020B Appendix A.7

**Preloaded joints carried 1.4% less load on average; statistically insignificant**

- Tests at NASA/Marshall in 2010 (Ref. 42) showed similar results.
  - 3/8" 180-ksi A286 bolts
  - Tests performed with threads in shear plane and with threads not in shear plane

**Conclusion: Preload does not need to be included in fastener shear analysis.**

## Ultimate Margin of Safety for Bolt Shear

From Sec. 5 herein,

If the full-diameter body is in the shear plane and there is no more than one thread or incomplete runout thread in bearing (my recommendation; not in 5020B), the allowable ultimate shear load per shear plane is

$$P_{su\text{-allow}} = F_{su} \left( \frac{\pi D^2}{4} \right) \quad \text{(Eq. 5.2)} \\ \text{NASA-STD-5020B Eq. 12)}$$

$F_{su}$  = allowable ultimate shear stress  
 $D$  = nominal bolt diameter

Otherwise (threads in the shear plane or more than one thread or incomplete runout thread in bearing), the allowable ultimate shear load per shear plane is

$$P_{su\text{-allow}} = F_{su} A_m \quad \text{(Eq. 5.3)} \\ \text{NASA-STD-5020B Eq. 13, based on Ref. 42}$$

$A_m$  = minor-diameter area (see Sec. 2 herein)

$$MS_u = \frac{P_{su\text{-allow}}}{P_{su}} - 1 \quad \text{(Eq. 14)} \\ \text{where } P_{su} = FF_u \cdot FS_u \cdot P_{sL}$$

**Analysis also must account for applied shear interacting with applied tensile load and any significant bending moment. One way to do that is by use of an appropriate interaction criterion. (Our next topic ...)**

## Interaction: Threads Not In Shear Plane

For a fastener whose threads are not in the shear plane, with no more than one thread or runout thread in bearing, the following interaction criterion is substantiated by the Ref. 42 tests for combined shear and applied tension:

$$\left( \frac{P_{su}}{P_{su\text{-allow}}} \right)^{2.5} + \left( \frac{P_{tu}}{P_{tu\text{-allow}}} \right)^{1.5} \leq 1 \quad (\text{Eq. 9.1})$$

(Equivalent to NASA-STD-5020B Eq. 20 when bending stress is omitted)

**Note:** The above criterion is more conservative than the criterion in Ref. 3 (Astronautic Structures Manual), which uses exponents of 3 for shear and 2 for tension. Tests of A-286 bolts at Marshall Space Flight Center in 2010 (Ref. 42) showed ultimate failure at load combinations below those allowed by the traditional criterion. Equation 9.1, above, was derived to match the 2010 test results.

$P_{su}$  = design ultimate shear load =  $FF_u \cdot FS_u \cdot P_{sL}$   
 $P_{su\text{-allow}}$  = allowable ultimate shear load per Eq. 12  
 $P_{tu}$  = design ultimate tensile load =  $FF_u \cdot FS_u \cdot P_{tL}$   
 $P_{tu\text{-allow}}$  = allowable ultimate tensile load based on the tensile stress area

No need to include preload in the interaction check, based on results of the Ref. 42 tests

## Interaction with Bending: Threads Not In Shear Plane

For a fastener whose threads are not in the shear plane, with no more than one thread or runout thread in bearing (my recommendation), either of the following interaction criteria may be used for combined shear, tension, and bending:

$$\left( \frac{P_{su}}{P_{su\text{-allow}}} \right)^{2.5} + \left( \frac{P_{tu}}{P_{tu\text{-allow}}} + \frac{f_{bu}}{F_{tu}} \right)^{1.5} \leq 1 \quad (\text{Eq. 20})$$

$$\left( \frac{P_{su}}{P_{su\text{-allow}}} \right)^{2.5} + \left( \frac{P_{tu}}{P_{tu\text{-allow}}} \right)^{1.5} + \left( \frac{f_{bu}}{F_{bu}} \right) \leq 1 \quad (\text{Eq. 21})$$

No need to include preload in the interaction check

$P_{su}$  = design ultimate shear load  
 $P_{su\text{-allow}}$  = allowable ultimate shear load per Eq. 12  
 $P_{tu}$  = design ultimate tensile load  
 $P_{tu\text{-allow}}$  = allowable ultimate tensile load based on the tensile stress area  
 $f_{bu}$  = design ultimate bending stress  
 $F_{bu}$  = plastic bending allowable ultimate stress (see Chap. 8 of Ref. 16)

Regarding the provided interaction criteria, NASA-STD-5020B says ...

*These interaction equations may be used, but other interaction equations based on test data or test-substantiated analysis methods may be substituted.*

## **Problem: How Do We Calculate Bending Stress in a Bolt?**

- Many different methods are used,
  - and many arguments take place regarding whether the selected method is adequate.
- Linear methods tend to be overly conservative.
  - Local yielding allows new load paths, with the result being the bolt can carry more load than is predicted linearly, even when using a plastic bending allowable.
- Problem: I am aware of no accepted empirical method in the public domain.

However, testing of shimmed single-shear joints at Marshall Space Flight Center in 2018 (Ref. 12) provides an opportunity to derive a simple failure criterion for ultimate strength that accounts for shims.

See next page ...

## Assessing an A-286 Bolt in a Shimmed Single-Shear Joint

Proposed criterion, in the form of an allowable applied load, based on the Ref. 12 test program:

The allowable ultimate load,  $P_{su-a}$ , is

$$P_{su-a} = P_{su-allow} \left[ 1 - 0.5 \left( \frac{t_{shim}}{D} \right) \right] \quad \text{(Eq. 9.4)}$$

Allowable ultimate bolt load for single-shear joint without shims

Shim thickness

Bolt diameter

Applicability and limitations:

- A-286 bolt, aluminum alloy joint members
- Bolt with a standard protruding head, not a flush head for a countersunk hole
- Shear load only; no applied tension
- Shim thickness no greater than bolt diameter
- Threads not in the shear plane, and no more than one incomplete runout thread in bearing
- Bolt-hole diameter no larger than 1.12 times bolt diameter
- For assessing bolt ultimate failure only, not bearing ultimate or yield failure

**For the comparison with test data, see Appendix 9A.2 to this section.**

## Interaction: Threads In Shear Plane

With threads in the shear plane, such as the case of a fastener installed in a threaded insert, or when more than one thread is in bearing, either of the following criteria may be used for combined shear, tension, and bending:

$$\left( \frac{P_{su}}{P_{su\text{-allow}}} \right)^{1.2} + \left( \frac{P_{tu}}{P_{tu\text{-allow}}} + \frac{f_{bu}}{F_{tu}} \right)^2 \leq 1 \quad (\text{Eq. 22})$$

$$\left( \frac{P_{su}}{P_{su\text{-allow}}} \right)^{1.2} + \left( \frac{P_{tu}}{P_{tu\text{-allow}}} \right)^2 + \left( \frac{f_{bu}}{F_{bu}} \right) \leq 1 \quad (\text{Eq. 23})$$

Reference for the above interaction criterion when bending is set to zero: tests conducted at NASA/Marshall in 2010 (Ref. 42)

**Note that  $P_{su\text{-allow}}$  in the above criteria is based on the minor-diameter area per Eq. 13.**

$P_{su}$  = design ultimate shear load  
 $P_{su\text{-allow}}$  = allowable ultimate shear load per Eq. 13  
 $P_{tu}$  = design ultimate tensile load  
 $P_{tu\text{-allow}}$  = allowable ultimate tensile load based on the tensile stress area  
 $f_{bu}$  = design ultimate bending stress  
 $F_{bu}$  = plastic bending allowable ultimate stress

No need to include preload in the interaction check, based on results of the Ref. 42 test

## Margin of Safety for Interaction

Based on the assumption that, if the applied loads (tensile, shear, and bending) were to increase, they would do so proportionally, we can solve for a scaling factor,  $a$ , that causes a zero-margin condition.

Example—threads not in shear plane:

$$\left( \frac{aP_{su}}{P_{su\text{-allow}}} \right)^{2.5} + \left( \frac{aP_{tu}}{P_{tu\text{-allow}}} + \frac{af_{bu}}{F_{tu}} \right)^{1.5} = 1 \quad (\text{Eq. 9.2})$$

The ultimate margin of safety is then

$$MS_u = a - 1 \quad (\text{Eq. 9.3})$$

Note: The team that developed NASA-STD-5020 considered including the above equations in the standard but decided not to require such a calculation.

I recommend calculating a margin of safety, using the above equations, because it provides useful information.

## Class Problem 9-5: Ultimate Margins of Safety for Bolt Shear and Interaction

For the joint used in class problem 9-1, as defined on p. 9-6:

**Calculate ultimate margins of safety for (1) shear by itself and (2) interaction of tension and shear.**

- Given:
- Bolt diameter is 3/8".
  - Allowable ultimate tensile load,  $P_{tu\text{-allow}} = 15,200$  lb
  - The bolt specification does not provide an allowable ultimate shear load,  $P_{su\text{-allow}}$ , but the allowable ultimate shear stress of the bolt material,  $F_{su} = 95$  ksi.
  - Threads are not in the shear plane, and there are no shims or spacers between joint members.
  - Maximum preload is 11,070 lb, minimum preload is 6470 lb (from class problem 9-1).
  - Design ultimate tensile and shear loads:

$$P_{tu} = 9000 \text{ lb}$$

$$P_{su} = 2510 \text{ lb}$$

## Joint-slip Analysis: Applied Shear Only (no applied tension)

Coefficient of friction,  $\mu$ , for joint-slip analysis (in absence of approved test data):

- 0.2 for uncoated, nonlubricated, cleaned metal surfaces
- 0.1 for all other surfaces, including nonmetallic surfaces and metallic surfaces that are coated with any substance, such as paint or conversion coating (e.g., alodine)

Slip margin of safety for joints loaded in shear only:

- Conservative check for slipping at the highest loaded fastener:

$$MS_{\text{slip}} = \frac{\mu P_{p-\text{min}}}{FF \cdot FS \cdot P_{sL}} - 1 \quad (\text{Eq. 9.5})$$

- Less conservative (but acceptable) check for a joint that is concentrically loaded (load passes through bolt-pattern centroid), using bolts of the same type and with the same nominal preload:

$$MS_{\text{slip}} = \frac{\mu n_f P_{p-\text{min}}}{FS \cdot P_{sL-\text{joint}}} - 1 \quad (\text{Eq. 85})$$

$\mu$  = coefficient of friction  
 $P_{p-\text{min}}$  = minimum preload  
 $FS$  = factor of safety applicable to the analysis (e.g., yield)  
 $FF$  = applicable fitting factor  
 $P_{sL}$  = limit shear load for the bolt  
 $n_f$  = number of fasteners  
 $P_{sL-\text{joint}}$  = total limit shear load acting on the joint

Equation 9.5 is not in NASA-STD-5020B; it's a simplifying derivation from Eq. 85.

## Slip Analysis for Joints Loaded in Shear and Tension Simultaneously

Based on the assumption that the clamp stiffness is infinite, so the compressive force between joined parts decreases by an amount equal to the applied tensile load,

$$\text{Friction load that can be developed: } P_f = \mu(n_f P_p - P_{t\text{-joint}}) \quad (\text{Eq. 81})$$

For the case in which shear is concentrically applied and, if the applied tensile and shear loads were to increase, they would do so proportionally, we can solve for a scaling factor,  $a$ , that causes a zero-margin condition:

$$\frac{\mu(n_f P_{p\text{-min}} - a \cdot FS \cdot P_{tL\text{-joint}})}{a \cdot FS \cdot P_{sL\text{-joint}}} - 1 = 0 \quad (\text{Eq. 82})$$

$$a = \frac{\mu n_f P_{p\text{-min}}}{FS \cdot (P_{sL\text{-joint}} + \mu P_{tL\text{-joint}})} \quad (\text{Eq. 83})$$

The margin of safety for joint slip is  $a - 1$ , or

$$(\text{Eq. 84}) \quad MS_{\text{slip}} = \frac{n_f \mu P_{p\text{-min}}}{FS \cdot (P_{sL\text{-joint}} + \mu P_{tL\text{-joint}})} - 1$$

$\mu$  = coefficient of friction  
 $P_p$  = preload  
 $P_{t\text{-joint}}$  = tensile load acting on joint  
 $P_{p\text{-min}}$  = minimum preload  
 $FS$  = factor of safety applicable to the analysis  
 $P_{sL}$  = limit shear load for the bolt  
 $n_f$  = number of fasteners  
 $P_{tL\text{-joint}}$  = total limit tensile load acting on the joint  
 $P_{sL\text{-joint}}$  = total limit shear load acting on the joint

## Class Problem 9-6: Assessing Joint Slip at Limit Loads

For the joint used in class problem 9-1, as defined on p. 9-6:

**Assess joint slip at limit loads.**

- Given:
- The faying surfaces of the joint members are aluminum alloy with Iridite™ conversion coating.
  - Minimum preload is 6470 lb (from class problem 9-1).
  - Limit bolt tensile and shear loads (from class problem 4-2):

$$P_{tL} = 5590 \text{ lb}$$

$$P_{sL} = 1560 \text{ lb}$$

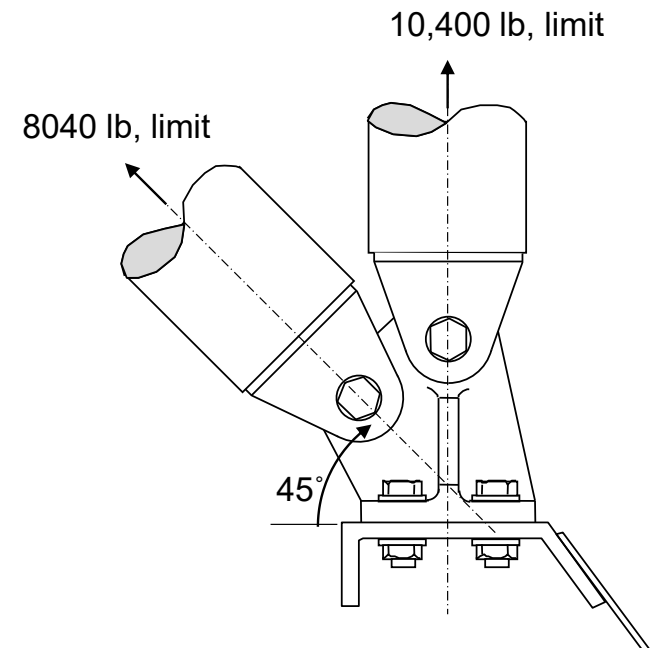

## Is Bolt Fatigue an Issue?

Many space programs do not assess bolt fatigue life.

- Doing so would be very time consuming and thus would drive cost.
- History tells us that bolts in all-metallic tension joints seldom fail in fatigue in the space industry when the preload is sufficient to prevent separation under service loads.
- The common assumption is that, by satisfying the strength criteria and the separation criteria (and, for missions involving humans, the fracture control criteria), bolt fatigue is not an issue.

Still, in some applications, a bolt can fail in fatigue even if the above criteria are met.

Examples:

- A bolt clamping flexible parts, such as rubber gaskets. Such a bolt could see high cyclic stress under cyclic applied loads.
- Hardware used for multiple missions.

**Verification of fatigue life should be expected for all flight fasteners.**

**But NASA does not want to drive unnecessary cost by requiring detailed fatigue analysis for each fastener.**

**If a particular program approves, verification may be as easy as checking off a list of characteristics that make up a “low risk” classification.**

## Fastener Fatigue Requirement in NASA-STD-5020B Sec. 4.5

**All threaded fastening systems shall be designed to withstand the entire service life, including the life scatter factor specified by the program or project, and service environment without fatigue failure.**

The italicized explanatory text in Sec. 4.5 says ...

*Typically, verification of service life may be by either of the following methods:*

- *Fatigue analysis using the fatigue analysis factor and service life factor specified in the applicable structural requirements (e.g., NASA-STD-5001), or*
- *Fatigue testing using the service life factor specified in the applicable structural requirements (e.g., NASA-STD-5001).*

*Alternatively, with the prior approval of the delegated NASA Technical Authority, similarity to the hypothetical fastened joint described ~~below and in~~ Appendix C may be used to verify a fatigue failure is unlikely to occur in lieu of fatigue analysis or testing. This approach does not relieve any fracture control requirements.*

typo in  
5020B

For fracture critical fasteners, the required crack-growth analysis verifies fatigue life.

## NASA-STD-5020B Appendix C: Justification for Low Likelihood of Fatigue Failure

All of the following major bullets must be true for a fastener to be considered similar to the bolt for which the analysis in NASA-STD-5020B Appendix C applies:

- The design service load spectrum is enveloped by the one used for the assessed bolt. (See Appendix 9A.3 herein and NASA-STD-5020B Appendix C, Table 7.)
- The fastener is made of A-286 alloy. (*Why? Because the NASA-STD-5020 team did fatigue testing of A-286 bolts only.*)
- Either
  - the fastener has UNJ or MJ threads rolled after heat treatment\* and the limit tensile load multiplied by any factors applicable to fatigue analysis does not exceed 50% of the fastener's allowable ultimate tensile load,
  - or the fastener has UNR threads rolled after heat treatment\* and the limit tensile load multiplied by any factors applicable to fatigue analysis does not exceed 40% of the fastener's allowable ultimate tensile load.
- $E_c > E_b/3$  for all clamped parts other than washers (elastic modulus comparison)
- $e/D \geq 1.5$  (minimum edge-distance ratio for joint members)
- Requirement TFSR 10 (separation, sec. 4.4.3) is satisfied.\*
- If threads are in the shear plane\*, either a dedicated shear-transfer device such as a shear pin or dowel pin is present or analysis per the requirements of section 4.4.6 demonstrates no slipping occurs.

\*See notes on next page ...

## Some Notes Regarding the Criteria for Low Likelihood of Fatigue Failure

- ...
- Either
  - the fastener has UNJ or MJ threads rolled after heat treatment\* and the limit tensile load multiplied by any factors applicable to fatigue analysis does not exceed 50% of the fastener’s allowable ultimate tensile load,
  - **or the fastener has UNR threads rolled after heat treatment** and the limit tensile load multiplied by any factors applicable to fatigue analysis does not exceed 40% of the fastener’s allowable ultimate tensile load.
- ...
- Requirement TFSR 10 (separation, sec. 4.4.3) is satisfied **with the recommended criterion that the limit tensile load acting on the fastener is no greater than minimum preload.**
- **If threads are in the shear plane**, either a dedicated shear-transfer device such as a shear pin ...

Thread rolling after heat treatment should not have been required in the criteria because the criteria were derived from fatigue tests of NAS1351 socket head cap screws, which have no requirement for threads to be rolled after heat treatment.

The highlighted phrase is not in 5020B, but it should be. When original 5020 team derived these criteria, the gapping criterion recommended herein was a “shall” statement (requirement).

Based on the results of single-shear testing with shims at NASA MSFC (Ref. 12), I would rephrase this statement to say “If threads are in the shear plane or if more than one runout thread is in bearing.”

## NASA-STD-5020B Appendix C: Justification for Low Likelihood of Fatigue Failure (continued)

- The basic release of NASA-STD-5020 referred to a “low-risk fatigue classification”.
  - Verification of fatigue life, if approved, was by meeting the stipulations in the bullet list (two pages ago herein).
- 5020B calls it “low likelihood of fatigue failure”.
  - Verification of fatigue life, if approved, is by similarity to the fastening system assessed for fatigue life, as determined by meeting the same stipulations as before.
- In essence, nothing really changed other than the terminology, which is now more consistent within NASA.

**Appendix 9A.3 at the end of this section is the original report from which Appendix C in NASA-STD-5020 was derived.**

**This original report includes additional detail not provided in any released version of 5020.**

## Appendices to Section 9

- 9A.1 Additional data and requirements from NASA-STD-5020B pertaining to preload calculation
- 9A.2 Accounting for bolt bending in a shimmed single-shear joint
- 9A.3 Justification for low likelihood of fatigue failure: the original report, which was condensed to become the main part of NASA-STD-5020B Appendix C

## Appendix 9A.1: Calculating Maximum and Minimum Initial Preloads

Generic equations for any method of establishing preload:

Maximum initial preload for strength analysis and fatigue analysis

$$\Rightarrow P_{pi-max} = c_{max} (1 + \Gamma) P_{pi-nom} \quad (\text{Eq. 3})$$

Ratio of max (or min) value of the control parameter (e.g., torque) to nominal value of control parameter

Preload variation

Nominal initial preload

Minimum initial preload for use in separation analysis of separation-critical joints and for fatigue analysis (when more fatigue damage results from a low preload than a high preload)

$$\Rightarrow P_{pi-min} = c_{min} (1 - \Gamma) P_{pi-nom} \quad (\text{Eq. 4})$$

Minimum initial preload for use in joint-slip analysis and separation analysis of joints that are not separation critical:

$$\Rightarrow P_{pi-min} = c_{min} \left( 1 - \frac{\Gamma}{\sqrt{n_f}} \right) P_{pi-nom} \quad (\text{Eq. 5})$$

Number of fasteners in the joint

## Appendix 9A.1: Calculation of Nominal Initial Preload

NASA-STD-5020B Sec. 4.3.2:

Calculation of the nominal (mean) initial preload,  $P_{pi-nom}$ , shall be substantiated by tests of a minimum of six sets of the fastening system hardware per Table 2, Nominal Preload Determination, to determine the relationship between initial preload and the parameter controlled during installation (torque, turn-of-nut, turn-angle, or bolt stretch).

NASA-STD-5020B Table 2

	Torque Control <sup>(1,2)</sup>	Turn-of-Nut or Turn-Angle	Bolt Stretch
The fastening system hardware has the same diameter and thread form, the same type and number of washers, same materials, and same nut/nut plate/insert as the flight assembly. The clamped part and washer that are adjacent to a non-rotating bolt head or non-rotating nut are not critical and are allowed to vary from the flight assembly.	R	R	R
Cleaning, lubricants, and lubrication process are the same as flight assembly.	R	R	NR
The fastening system hardware is the same specification (part number) as the flight assembly hardware.	NR	R	R
Installation process is the same as flight assembly.	NR	R	R
R=Required, NR=Desirable but not required			
<sup>(1)</sup> At least three tests (install, torque, and removal) should be performed on each of the six sets of fastening system hardware for a total of eighteen tests, unless reuse is prohibited in the flight assembly.			
<sup>(2)</sup> See NASM 1312-15, Fastener Test Methods, Method 15, Torque-Tension, for guidance for torque-tension testing.			

## Appendix 9A.1: Preload Variation

NASA-STD-5020B Sec. 4.3.3: The preload variation,  $\Gamma$ , used to calculate the minimum and maximum initial preload shall be based on the criteria of Table 3.

NASA-STD-5020B Table 3

Method	Separation Critical	Non-Separation Critical
Torque Control	Envelope of statistical basis <sup>(1)</sup> and variation to satisfy Table 2 <sup>(2)</sup> while using <ul style="list-style-type: none"> <li>a. Lot-specific testing (testing the procurement lot of fastening system hardware that will be used for spaceflight)<sup>(3)</sup> or</li> <li>b. Testing equal numbers of sets of fastening system hardware of the same specification as the flight-assembly hardware, from each of at least three procurement lots<sup>(3)</sup></li> </ul>	a. Statistical basis <sup>(1)</sup> , or b. Greater of <ul style="list-style-type: none"> <li>1) 25% (if lubricated),</li> <li>2) 35% (if non-lubricated or as-received),</li> <li>3) Variation from tests to satisfy Table 2<sup>(2)</sup></li> </ul> <p><i>“... a fastener is considered to be lubricated if a solid-film, grease, or liquid lubricant is applied to the threads and to the turning bearing surfaces of the nut or the bolt head (or to the washer under the nut or the bolt head).”</i></p>
Turn-of-Nut or Turn Angle	Envelope of statistical basis <sup>(1)</sup> and variation to satisfy Table 2 <sup>(2)</sup>	a. Statistical basis <sup>(1)</sup> , or b. Greater of 1) 25% and 2) Variation from tests to satisfy Table 2 <sup>(2)</sup>
Bolt Stretch	Envelope of statistical basis <sup>(1)</sup> and variation to satisfy Table 2 <sup>(2)</sup>	a. Statistical basis <sup>(1)</sup> , or b. Greater of 1) 10% and 2) Variation from tests to satisfy Table 2 <sup>(2)</sup>

$P_{pi-maxa}$   
and  $P_{pi-mina}$   
are the  
actual max  
and min  
initial  
preloads  
from test  
data.

<sup>(1)</sup>90% probability and 95% confidence (two-sided distribution), with tests meeting the configuration requirements of Table 2.

<sup>(2)</sup>The variation from the tests to satisfy Table 2 is given by the minimum and maximum values of preload relative to the nominal preload such that  $\Gamma_{a-max} = P_{pi-maxa} / P_{pi-nom} - 1$  and  $\Gamma_{a-min} = 1 - P_{pi-mina} / P_{pi-nom}$ .

<sup>(3)</sup>Each fastener to be installed, torqued, and removed at least three times unless reuse is prohibited for the flight assembly. When reuse is prohibited, only the data from the first cycle is used.

## Appendix 9A.1: Establishing Nominal Initial Preload and Nominal Nut Factor when Installing Fasteners with Torque Control

The nominal initial preload,  $P_{pi-nom}$ , is the sample mean (average) preload for a given effective torque,  $T$ , as found in test:

$$P_{pi-nom} = \frac{1}{m} \sum_{j=1}^m P_{pi-j} \quad (\text{Eq. 31})$$

where  $j$  = test number  
 $P_{pi-j}$  = initial preload obtained in the  $j$ -th test  
 $m$  = number of tests

The nominal nut factor is then

$$K_{nom} = \frac{T}{DP_{pi-nom}} \quad (\text{Eq. 32})$$

← Not the same as taking the average of  $K$  values obtained by test

$D$  = nominal bolt diameter

Note:  $K_{nom}$  can be different for different effective torque values.

## Appendix 9A.2: Accounting for Bolt Bending in a Shimmed Single-Shear Joint Based on the Tests Documented in Ref. 12

Reference 12, “Aerospace Threaded Fastener Strength with Joint Shims”, documents a 2018 test program at Marshall Space Flight Center.

Using the fixtures shown at right, loads were applied at 0° (pure tension), 45° (tension and shear combined, shown), and 90° (pure shear).

- Some of the shear tests were with 15-5PH H1025 stainless steel pucks; others were with 2219-T87 aluminum pucks. The 45° tests were with steel pucks only.
- ¼” A-286 bolts, NAS1954C, from multiple lots; 180 ksi minimum tensile strength, 108 ksi minimum shear strength
- 0.280” nominal diameter for bolt holes
- Steel shims, thickness: 0”, 0.030”, 0.060”, 0.090”, 0.120”, 0.180”, and 0.240”
- Two nuts: NAS1291 for some tests, NAS1805 for others
- Torqued to 80 in-lb
- 3 bolts tested for each configuration

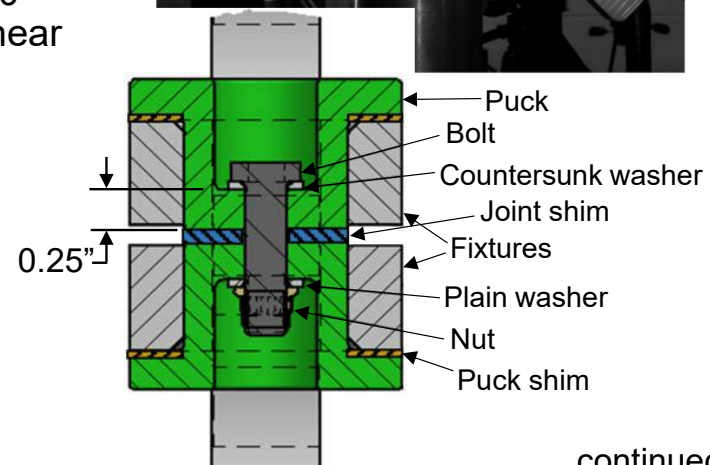
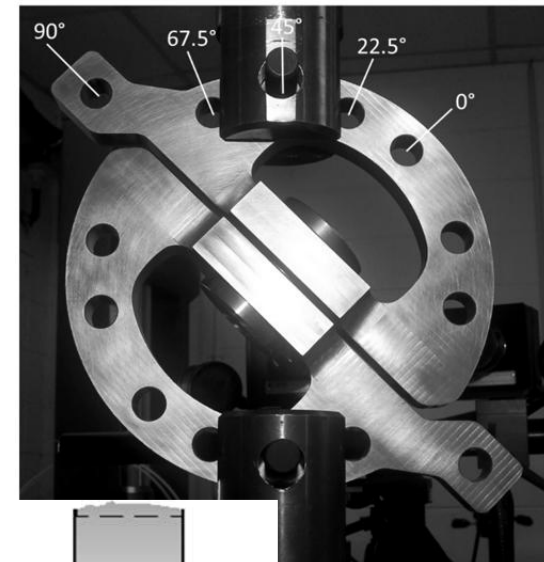

continued

## Appendix 9A.2, continued: My Objective

### Objective:

Derive ultimate-strength failure criteria for use in analysis of shimmed single-shear joints with A286 bolts and aluminum joint members, based on the Ref. 12 test data.

continued

## Appendix 9A.2, continued: Test Results with Aluminum Pucks

The tested ¼”-dia. bolts were of two lengths, NAS1954C9 and NAS1954C12, with length selected based on shim thickness. Three of each length were tested with 0.120” shims. In making the plot below, I discarded the results of testing the short (C9) bolts with 0.120” shims because several threads were in bearing, and failure occurred at the threaded section.

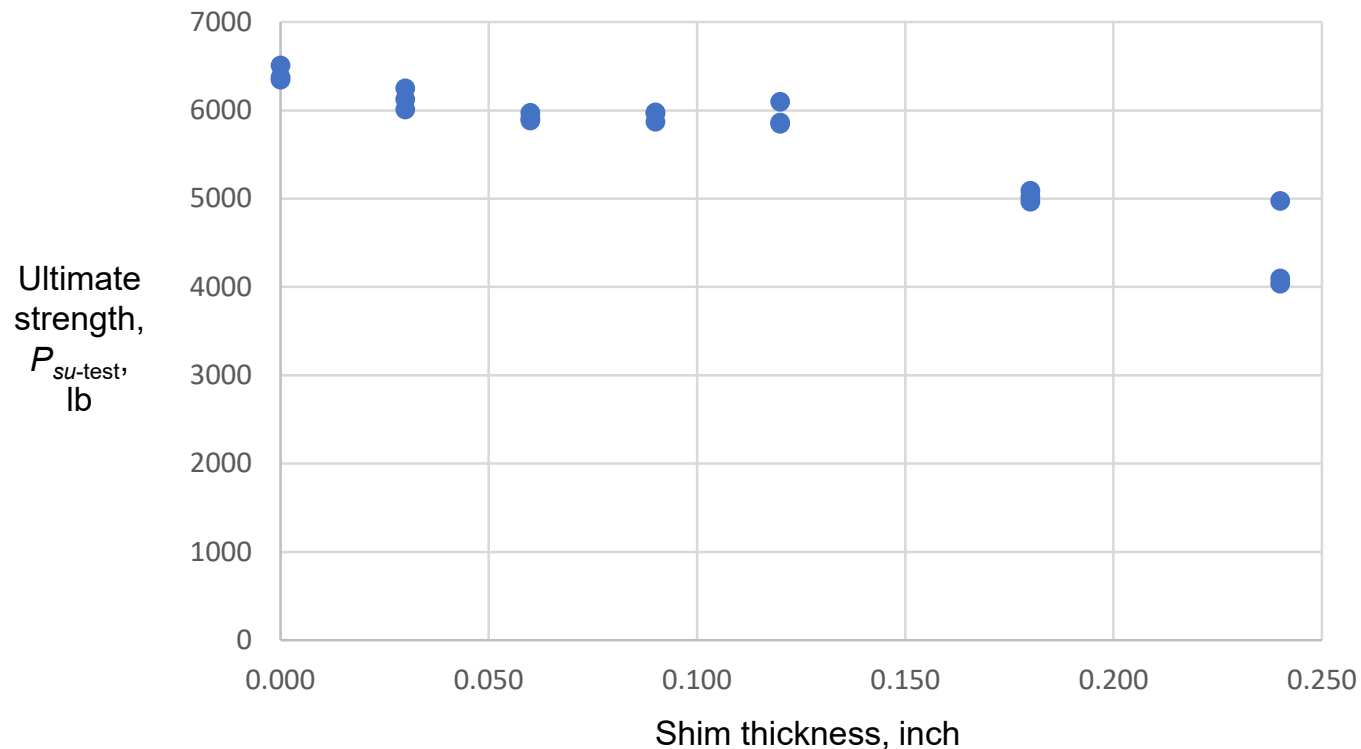

continued

## Appendix 9A.2, continued: Bolt Shear Strength

Average ultimate strength values for the bolts tested:

- Tensile strength = 9040 lb for five bolts tested (failure through threaded cross section)
- Single-shear strength without shims = 6409 lb for three bolts tested with aluminum pucks (failure of full-diameter body)
- If the bolts had been tested in double shear, per the standard test method, I believe the average shear strength used by an engineer for a single-shear joint would have been somewhat higher:

$$9040 \left( \frac{108}{180} \right) \left( \frac{0.0491}{0.0404} \right) = 6590 \text{ lb}$$

Minimum shear strength for the bolt material (points to 108)  
 Full-body shear area,  $A_s$  (points to 0.0491)  
 Minimum ult. tensile strength for the bolt material (points to 180)  
 Tensile stress area,  $A_t$  (points to 0.0404)

For use in deriving failure criteria, we'll use an allowable load for single shear of

$$P_{su\text{-allow}} = 6590 \text{ lb}$$

continued

## Appendix 9A.2, continued: Proposed Failure Criterion

Simple derived failure criterion, in the form of an allowable applied load, for assessing an A-286 bolt in a shimmed single-shear joint (see applicability and limitations below):

Allowable ultimate shear load with  $t_{\text{shim}} \leq D$ ,

$$P_{su-a} = P_{su\text{-allow}} \left[ 1 - 0.5 \left( \frac{t_{\text{shim}}}{D} \right) \right] \quad (\text{Eq. 9.4})$$

Allowable ultimate bolt load for single-shear joint without shims

Shim thickness

Bolt diameter

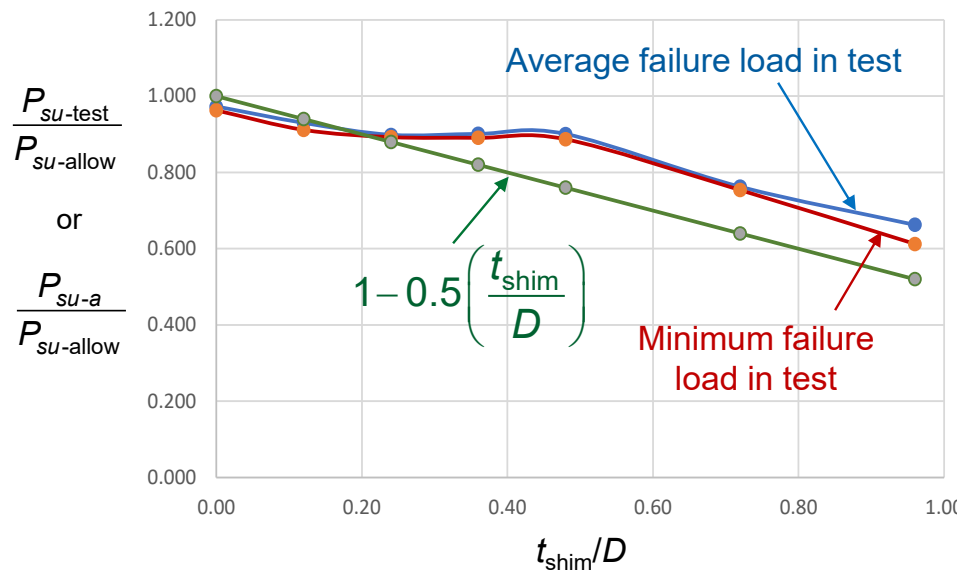

### Applicability and limitations:

- A-286 bolt, aluminum alloy joint members
- Bolt with a standard protruding head, not a flush head for a countersunk hole
- Shear load only; no applied tension
- Shim thickness no greater than bolt diameter
- Threads not in the shear plane, and no more than one incomplete runout thread in bearing
- Bolt-hole diameter no larger than 1.12 times bolt diameter
- For assessing bolt ultimate failure only, not bearing ultimate or yield failure

continued

## Appendix 9A.2, continued: Notes on Proposed Failure Criterion

Note 1: For no shim or thin shim, the failure criterion is on the unsafe side of the test data by about 3%. This is because of the assumption I made that the 6590 lb allowable shear load an engineer would use (half the double-shear strength) is 3% higher than the average failure load in the tests without shims (single-shear strength). Use of a fitting factor in analysis should more than compensate for the difference.

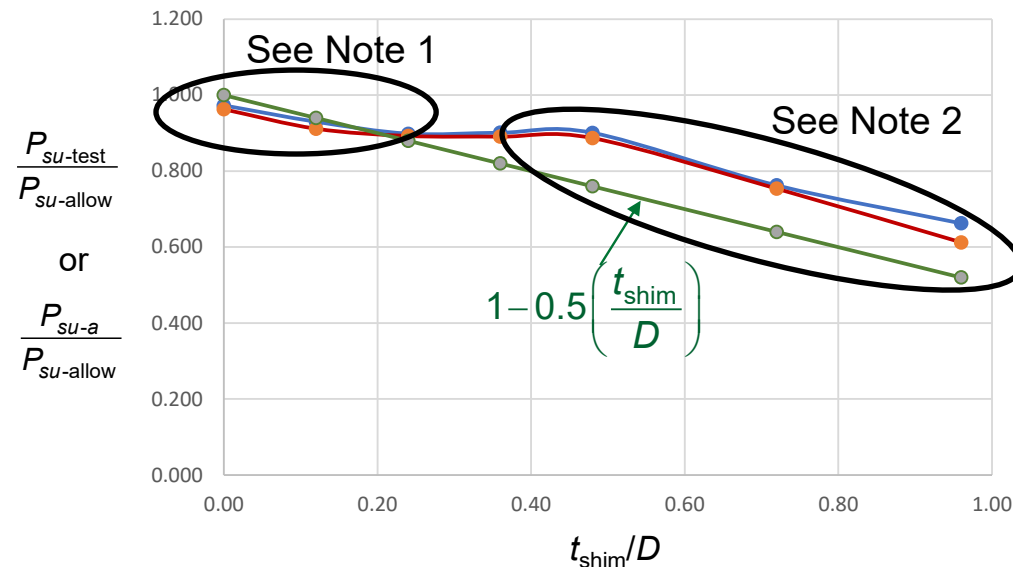

Note 2: For thick shims, the failure criterion appears excessively conservative, but I would not reduce this conservatism, given the limited test data. The test did not explore whether the failure load would be influenced by joint members made of aluminum alloys with different strength or with different thickness or edge distance, and other variables.

**Additional testing should be done to supplement this data.**

continued

## Appendix 9A.2, continued: Recommendations for Future Such Testing

Recommendation	Why
Use bolts from a single procurement lot for each bolt length tested, and test samples from each lot to determine strength.	Provides a better basis for comparison. There is typically little difference in strength between specimens that are from the same lot. With multiple lots, we can't always tell whether strength is different because of a test variable or because of lot-to-lot variation.
Use pucks or joint members from a single lot of material, and test samples from each lot to determine strength.	Strength of the joint-member materials would affect yield strength for such joints and may also affect ultimate strength.
Test with joint members made of a strong aluminum alloy, such as the 2219-T87 material used in this test, and also with a relatively weak alloy, such as 6061-T6.	Strength of the joint-member materials would affect yield strength for such joints and may also affect ultimate strength.
When testing specimens for a given lot to determine bolt or material strength, use standard test methods (e.g., double-shear test to determine bolt strength).	Enables apples-to-apples comparison with how analysis is done.
Test with different thickness of joint member.	To understand the effect of joint-member thickness on strength.
Measure and document actual thickness of joint members and shims for each test.	Allows us to account for actual thicknesses tested, given dimensional tolerances.
Use bolt holes that are only slightly larger in diameter than the bolts (e.g., 0.257" hole rather than a 0.280" hole for a 0.250" bolt).	Hole size may have an affect on strength, and it's good practice in design to keep holes tight when friction won't carry the applied shear load.
Select bolt lengths to ensure no more than one incomplete runout thread is in bearing, as shown in NASA-STD-5020B Fig. 2, when accounting for tolerances.	This is how actual joints in flight hardware should be designed. Allowing multiple full or runout threads in bearing causes the threaded cross section to get too close to the shear plane (faying surface). As evidenced in this test, failure can then occur through the threaded cross section.
Publish load-displacement plots for all tests.	Yield failure is defined mainly as detrimental permanent deformation, which varies with the structure being designed (e.g., launch vehicle primary structure vs. an optical instrument).

continued

## Appendix 9A.2, continued: Representative Load-Displacement Plots

Allowable bearing yield stress in Ref. 2 (MMPDS) is derived from the load that causes a permanent displacement equal to 2% of bolt diameter, with all the yielding taking place in one plate.

For a single-shear joint with both plates (joint members) yielding, this displacement would extend to 4% of bolt diameter.

4% of 0.250" is 0.010".

These plots show derivation of yield load for two configurations tested.

Remember, though, that your joint may not function properly with this much permanent displacement. "Yield failure" should be defined by how much permanent deformation your design can tolerate.

Representative load-displacement plots from Ref. 13 (aluminum pucks), with determination of yield load

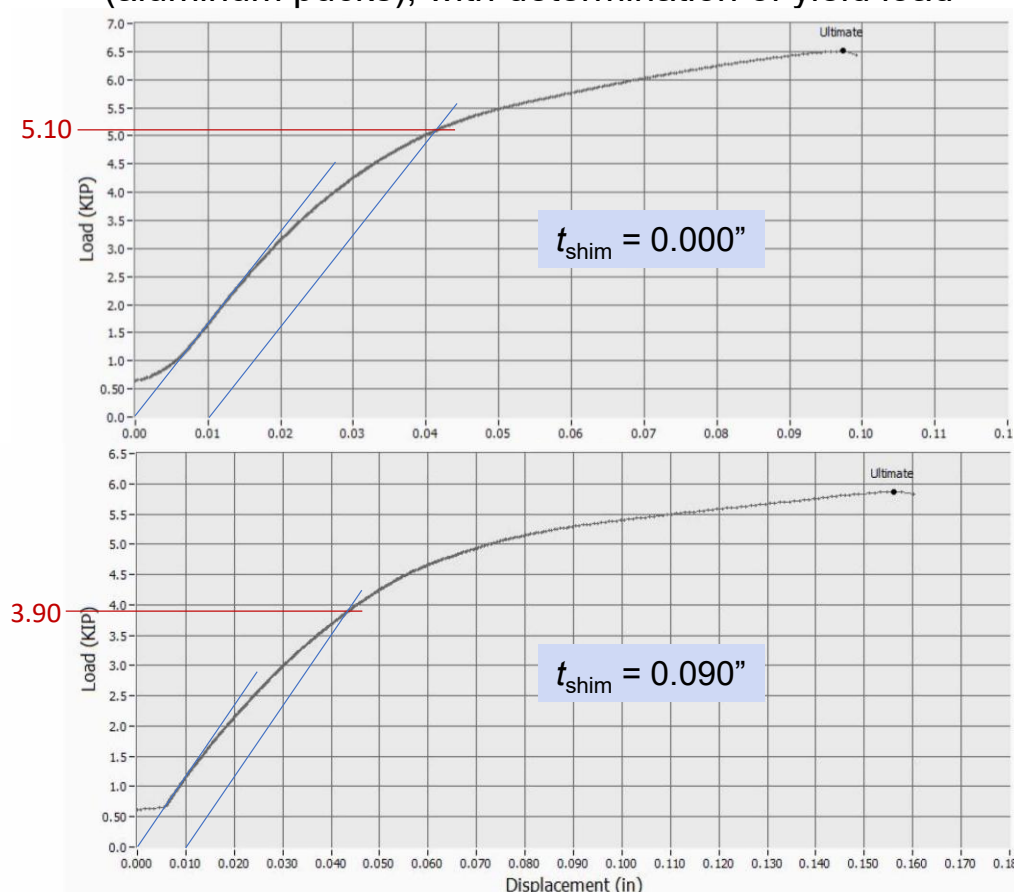

## Appendix 9A.3: Original Report Justifying Low Likelihood of Fatigue Failure (condensed version is in NASA-STD-5020 Appendix C)

The low-risk classification in NASA-STD-5020 section 4.2 is based on fatigue analysis using data acquired in tensile fatigue testing\* in 2011 of 160-ksi, A-286, NAS1351N fasteners and a hypothetical loading spectrum intended to be worst case for single-mission spaceflight hardware. The NAS1351N fastener is a socket-head cap screw with a UNR thread form, which has a specified root radius and is thus more fatigue resistant than the UN and M\*\* thread forms but is not as fatigue resistant as the UNJ and MJ thread forms, which have a larger specified root radius. Thus, any conclusions drawn from fatigue analysis using this test data are conservative for A-286 fasteners with rolled UNJ or MJ threads.

The fatigue tests were conducted on two sizes of fasteners, 0.190" diameter (4.83 mm) and 0.375" diameter (9.53 mm). The smaller fasteners were from three lots, each from a different supplier, whereas the 0.375"-diameter fasteners were from a single lot. Three fasteners were tested from each lot for each of eleven combinations of maximum load and stress ratio,  $R$ , which is defined as the minimum applied load within a loading cycle divided by the maximum applied load within that cycle. Each fastener was cycled within its given load parameters until rupture or until one million cycles was reached, whichever occurred first.

Prior to fatigue testing, ten fasteners from each lot were pull-tested to rupture in order to determine the range in ultimate tensile strength for each lot and compare it with the specified minimum strength for NAS1351N fasteners, which is based on an ultimate tensile strength of 160 ksi (1100 MPa) for the material. Actual material strengths of the fasteners tested, as derived by dividing the ultimate tensile load by the tensile stress area for the threads, varied from 192 – 214 ksi (1320 - 1480 MPa).

\*Tests performed at the Fastening and Joining Research Institute, Oakland University, Rochester, Michigan

\*\*When I wrote this original report, I was not aware that M threads also require a minimum root radius.

continued

## Appendix 9A.3: Original Report Justifying Low Likelihood of Fatigue Failure, continued

Fatigue-life data are typically presented in plots of stress vs. number of cycles (S-N). The S-N plots most often used for fatigue analysis are curves that best fit the scattered data. Traditionally, the scatter is accounted for in fatigue analysis by multiplying the anticipated number of loading cycles by a life factor of 4.

In the case of the NAS1351N fasteners tested, however, with such a wide spread between the actual strengths of the lots tested and the specified minimum strength, the test-derived S-N curves, if plotted with actual maximum stresses applied during the tests, cannot be safely used in fatigue analysis—even with the life factor of 4—for a procured fastener that is at or slightly above the specified minimum strength.

Thus, to allow the test data to be used safely in fatigue analysis, the data are presented in plots of normalized maximum load vs. number of cycles. The normalized maximum load is equal to the actual maximum load for a given test divided by the minimum ultimate tensile strength determined for the ten fasteners pull-tested to rupture within the corresponding fastener lot.

By normalizing the data in this manner, fatigue-life data for all lots can be combined to provide useful fatigue-life plots for design use. Figure 9-18 shows the resulting best-fit S-N curves for the stress ratios tested.

continued

## Appendix 9A.3: Original Report Justifying Low Likelihood of Fatigue Failure, continued

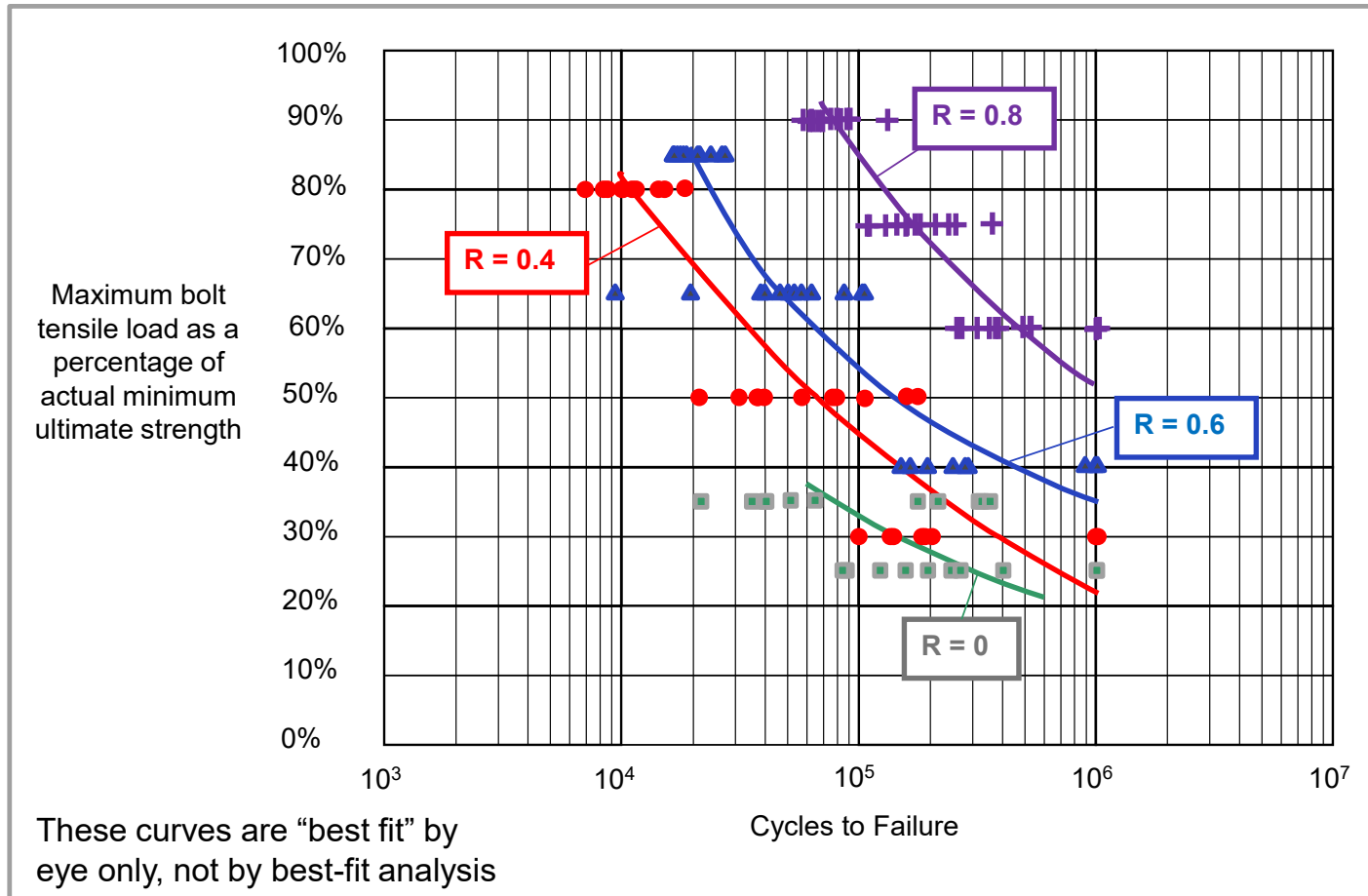

Fig. 9-18. Fatigue Data for NAS 1351N (A-286) Fasteners

continued

## Appendix 9A.3: Original Report Justifying Low Likelihood of Fatigue Failure, continued

These S-N curves were used to assess fastener fatigue life for a joint and a loading spectrum that together are intended to represent a worst-case scenario for single-mission flight hardware. The user should assess whether a particular application is enveloped by this set of conditions before relying on the conclusions of this study. The joint assessed is the joint used in DABJ example problem 8-c (NASA-STD-5020B Fig. 10), for which, prior to separation, the bolt's tensile load increases by a high percentage of applied load relative to most joints. The loading spectrum used in the fatigue analysis is shown in Table 9-1 (next page—same as 5020B Table 7). Each level of applied load is assumed to be fully reversed, tensile and compressive

continued

## Appendix 9A.3: Original Report Justifying Low Likelihood of Fatigue Failure, continued

Table 9-1. Hypothetical Applied Loading Spectrum.

Applied load as a percentage of limit load	Vibration Test	Flight	Total	Design (4x)
10%	4752	259	5011	20045
20%	13038	651	13689	54756
30%	18176	760	18935	75741
40%	19464	624	20088	80351
50%	17507	390	17897	71588
60%	13689	199	13889	55555
70%	9466	81	9547	38189
80%	5845	27	5872	23486
90%	3241	7	3249	12995
100%	2821	2	2822	11290
Total cycles	108000	3000	110999	443996

Basis (assumptions):

- The bolt is loaded highest by random-vibration response of a 200-Hz mode of vibration.
- The flight structural assembly is protoflight tested for 1 minute per axis, 3 dB above maximum predicted environment (MPE), at three levels of assembly, for a total of 3 minutes per axis.
- The 200-Hz mode is excited equally by all three axes of excitation (conservative assumption).
- Random vibration is at or near MPE for 15 seconds during launch.
- The loading spectra for test and launch are based on a Rayleigh distribution.
- Limit load for random vibration is  $3\sigma$  (three times the root-mean-square (RMS) value).
- All loading cycles above  $3\sigma$  from the Rayleigh distribution are included in the cycles at 100% limit load.
- The number of cycles at each load increment is multiplied by a life factor of 4 for fatigue analysis.

continued

## Appendix 9A.3: Original Report Justifying Low Likelihood of Fatigue Failure, continued

To assess the bolt in the subject joint for fatigue life, the applied-loading spectrum is transformed into two bolt-loading spectra, as shown in Table 9-2. One spectrum is based on the assumption of a high preload, equal to  $0.75P_{tu-allow}$ , and the other spectrum is based on the assumption of a low preload, equal to  $0.5P_{tu-allow}$ , which is the lowest the preload could be in order for the separation criteria to be met with a limit load equal to  $0.5P_{tu-allow}$ .

For each level of applied load, the total bolt load is calculated using Eq. 8. For fully reversed applied load, as assumed in this analysis, Eq. 8 is conservatively assumed to apply for compressive loading as well as for tensile loading, such that the mean load is equal to the preload.

For a given joint, the percentage of applied load by which the bolt load increases,  $n\phi$ , is commonly assumed to be a constant, regardless of the applied load magnitude, until separation occurs. In actuality,  $n\phi$  has a nonlinear relationship with applied load; separation is gradual, as an effective diameter of clamped material recedes. A nonlinear finite element analysis (FEA) of the joint used in DABJ example problem 8-c (see Fig. 9-10) was performed to understand the relationship between  $n\phi$  and the ratio of applied load to preload. The  $n\phi$  values shown in Table 9-2 reflect the results of this FEA.

continued

## Appendix 9A.3: Original Report Justifying Low Likelihood of Fatigue Failure, continued

Table 9-2. Derived Bolt-loading Spectra.

All loads are normalized to the allowable ultimate tensile load, $P_{tu-allow}$								
Limit load, $P_{tL} = 0.5$ .								
Stress ratio, $R = (\text{min load})/(\text{max load})$								
<b>Case 1: High preload</b>								
Applied load as a percentage of limit load	Design cycles, $n_i$ (4x)	Mean load (preload)	Applied load divided by preload	$n\phi$	Max load	Min load	Stress ratio, $R$	
10%	20052	0.75	0.07	0.07	0.754	0.747	0.99	
20%	54760	0.75	0.13	0.06	0.756	0.744	0.98	
30%	75744	0.75	0.20	0.06	0.759	0.741	0.98	
40%	80356	0.75	0.27	0.06	0.762	0.738	0.97	
50%	71592	0.75	0.33	0.06	0.765	0.735	0.96	
60%	55560	0.75	0.40	0.07	0.771	0.729	0.95	
70%	38196	0.75	0.47	0.07	0.775	0.726	0.94	
80%	23492	0.75	0.53	0.08	0.782	0.718	0.92	
90%	13000	0.75	0.60	0.09	0.791	0.710	0.90	
100%	11292	0.75	0.67	0.10	0.800	0.700	0.88	
<b>Total</b>	<b>444044</b>							
<b>Case 2: Low preload</b>								
Applied load as a percentage of limit load	Design cycles, $n_i$ (4x)	Mean load (preload)	Applied load divided by preload	$n\phi$	Max load	Min load	Stress ratio, $R$	
10%	20052	0.5	0.10	0.07	0.504	0.497	0.99	
20%	54760	0.5	0.20	0.06	0.506	0.494	0.98	
30%	75744	0.5	0.30	0.06	0.509	0.491	0.96	
40%	80356	0.5	0.40	0.07	0.514	0.486	0.95	
50%	71592	0.5	0.50	0.08	0.520	0.480	0.92	
60%	55560	0.5	0.60	0.09	0.527	0.473	0.90	
70%	38196	0.5	0.70	0.11	0.539	0.462	0.86	
80%	23492	0.5	0.80	0.13	0.552	0.448	0.81	
90%	13000	0.5	0.90	0.15	0.568	0.433	0.76	
100%	11292	0.5	1.00	0.17	0.585	0.415	0.71	
<b>Total</b>	<b>444044</b>							

continued

## Appendix 9A.3: Original Report Justifying Low Likelihood of Fatigue Failure, continued

Miner's rule was used in this study as the failure criterion:

$$D = \sum_{i=1}^j \frac{n_i}{N_i} \leq 1$$

where  $D$  is the cumulative damage,  $n_i$  is the number of loading cycles at a given stress level,  $N_i$  is the number of cycles to failure at that stress level, and  $j$  is the number of different stress levels.

For many of the load levels shown in the Table 9-2 loading spectra, the stress ratio,  $R$ , is higher than 0.8, which is the maximum value tested. Based on the trend seen from the S-N curves in Fig. 9-18, the allowable loading cycles,  $N$ , for any cycle in which  $R \geq 0.9$  is assumed to be 1,000,000. For any cycle in which  $0.8 < R < 0.9$ , the S-N curve for  $R = 0.8$  is conservatively used.

Table 9-3 shows the results of the fatigue analyses. With both loading spectra, the Miner's rule criterion passes.

continued

## Appendix 9A.3: Original Report Justifying Low Likelihood of Fatigue Failure, continued

Table 9-3. Results of Fastener Fatigue Analysis for the Hypothetical Joint and Loading Spectra.

Max load is normalized to the allowable ultimate tensile load, $P_{tu-allow}$ .					
Case 1: High preload					
Design cycles, $n_i$ (4x)	Max load	Stress ratio, $R$	Allowable cycles, $N_i$	$n_i/N_i$	
20052	0.754	0.99	1000000	0.020	
54760	0.756	0.98	1000000	0.055	
75744	0.759	0.98	1000000	0.076	
80356	0.762	0.97	1000000	0.080	
71592	0.765	0.96	1000000	0.072	
55560	0.771	0.95	1000000	0.056	
38196	0.775	0.94	1000000	0.038	
23492	0.782	0.92	1000000	0.023	
13000	0.791	0.90	1000000	0.013	
11292	0.800	0.88	125000	0.090	
444044				0.523	
				PASS	
Case 2: Low preload					
Design cycles, $n_i$ (4x)	Max load	Stress ratio, $R$	Allowable cycles, $N_i$	$n_i/N_i$	
20052	0.504	0.99	1000000	0.020	
54760	0.506	0.98	1000000	0.055	
75744	0.509	0.96	1000000	0.076	
80356	0.514	0.95	1000000	0.080	
71592	0.520	0.92	1000000	0.072	
55560	0.527	0.90	800000	0.069	
38196	0.539	0.86	750000	0.051	
23492	0.552	0.81	700000	0.034	
13000	0.568	0.76	400000	0.033	
11292	0.585	0.71	200000	0.056	
444044				0.545	
				PASS	

continued

## Appendix 9A.3: Original Report Justifying Low Likelihood of Fatigue Failure, Conclusions

The above analysis shows that, for a fastener meeting all of the stipulations for low-risk classification, fatigue under tensile loading is not a concern for the above hypothetical loading spectrum.

The test data used in this study are from testing of NAS1351N fasteners, which have the UNR thread form. Although the study justifies a limit tensile load as high as  $0.5P_{tu-allow}$ , the low-risk classification allows a limit tensile load of only  $0.4P_{tu-allow}$  for fasteners having the UNR thread form. This apparent discrepancy is intentional as a result of uncertainty, given the limited fatigue data used in the analysis and the assumptions made in the analysis.

The UNJ and MJ thread forms have larger root radii than UNR and thus have better fatigue life. Given this fact along with the lack of fatigue data for A-286 fasteners with UNJ or MJ threads, the low-risk classification allows a limit tensile load of  $0.5P_{tu-allow}$  for fasteners having UNJ or MJ threads based on the results of the above analysis.

## Appendix A

# Finite Element Modeling of Bolted Joints with Nastran

Permission is granted by Instar for anyone to freely copy, distribute, and print this material, but only in its unaltered form. This section may be separately copied or printed, but only in its entirety, including this page and with headers and footers intact. Unaltered individual figures and tables and portions of text may be copied or used, but only with text in quotes and with the following statement "Source: Design and Analysis of Bolted Joints (DABJ) course book, Thomas P. Sarafin, Instar Engineering and Consulting, Inc. Reproduced with permission." The date of last revision also should be included in the reference. If you have questions, contact [tom.sarafin@instarengineering.com](mailto:tom.sarafin@instarengineering.com).

## Appendix A: Finite Element Modeling of Bolted Joints

# Objectives

**The modeling techniques herein are for the purpose of reasonably representing stiffness of preloaded joints to predict modes of vibration, dynamic loads, and load distribution.**

Remember what we discussed in Sec. 4, though:

Linear-elastic FEA, with modeling techniques such as those described herein, does not account for how loads can redistribute between bolts once yielding occurs in or near the highest-loaded bolt.

**At times it's appropriate to make detailed models for the purpose of predicting stresses or the total load in a preloaded bolt—or just understanding a problem better—but those objectives are not addressed here.**

## Appendix A: Finite Element Modeling of Bolted Joints

### Opening Thoughts

A bolted joint is one of the most difficult things to represent with a finite element model (FEM).

- When a model inadequately represents a structure's stiffness, modes of vibration, or load distribution, the inaccuracy is usually in the joints.

With Nastran, the CBUSH element is a popular choice for modeling bolts for several reasons:

1. A CBUSH element can (and should, in my opinion) be used between coincident nodes, whereas CBARs cannot.
2. It's historically been easier to get force recovery for CBUSH elements than for rigid elements such as RBARs.
3. Many analysts believe the ability to set stiffness values with CBUSH elements, based on estimated bolt stiffness, makes the model more accurate than representing bolts with RBARs.

**However, reason 3, above, is usually incorrect ...**

continued

## Appendix A: Finite Element Modeling of Bolted Joints Opening Thoughts, continued

Consider the following statement from a popular paper\*:

*“The FEM representation of the fastener should capture the shear and bending stiffness of the fastener and the bearing stiffness at the fastener-joined part interaction.”*

\*Rutman, Alexander, et al. “Fastener Modeling for Joining Parts Modeled by Shell and Solid Elements.” 2007 Americas Virtual Product Development Conference, October 11-12, 2007.

**What’s wrong with this advice for a model meant to predict modes of vibration and load distribution in a structural assembly?**

continued

## Appendix A: Finite Element Modeling of Bolted Joints

### Opening Thoughts, continued

The key thing to remember when modeling a preloaded joint is that the clamp force between fittings (joined parts) creates load paths that are normally much stiffer than the bolt itself

Once a bolt is preloaded, it is no longer the main load path. It's in parallel with a stiffer load path.

In the model (most likely), all the load must go through the bolt element (springs in series rather than in parallel).

Under tensile loading, the clamped material can create a load path that can be an order of magnitude stiffer than the bolt.

And, of course, when load reverses and the joint goes into compression, the bolt itself is not in the load path.

We also don't want to model the bolt's actual stiffness in a shear joint. A clamped shear joint carries load in friction, at least until the friction capability is exceeded, and the stiffness of the friction load path is far greater than the shear and bending stiffness of the bolt.

## Appendix A: Finite Element Modeling of Bolted Joints Modeling a Preloaded Tension Joint

To model a tension joint, start with an understanding of the compression caused by the bolt preload:

Floating Fastener  
(Through Bolt)

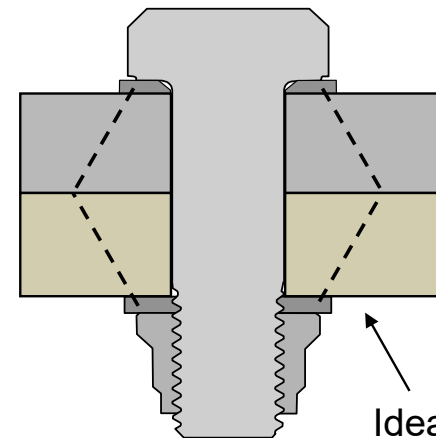
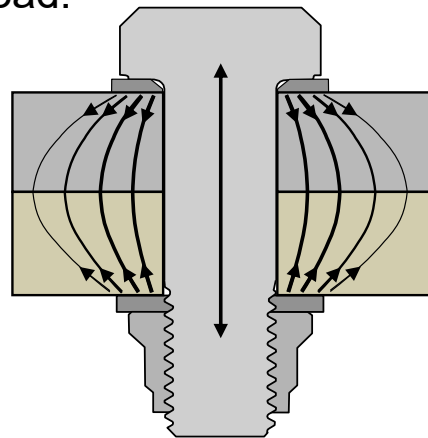

Fixed Fastener (with  
Tapped Hole or  
Threaded Insert)

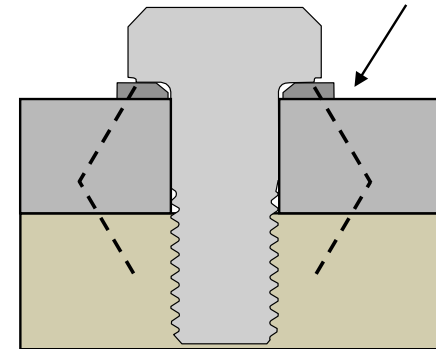
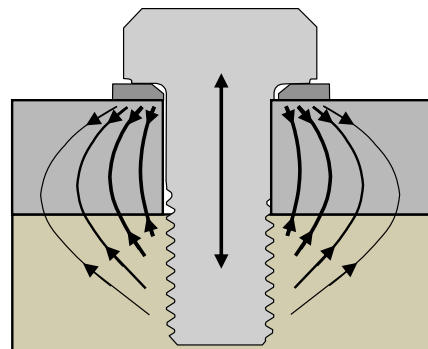

## Appendix A: Finite Element Modeling of Bolted Joints

### Load Paths in a Preloaded Joint under Applied Tension

- When a tensile load is applied to a preloaded joint, the stiffest load path is the relieving of compression between faying surfaces nearest the tension walls (dashed red line at right). That's the first location to gap.
- As the compression “circle” recedes with gradual gapping, the bolt takes a higher percentage of applied load.
- Because we typically design a joint not to gap at limit load or higher, we want to make a model that represents the preloaded (non-gapped) condition.
- For linear-elastic analysis, we want the model to represent average stiffness.

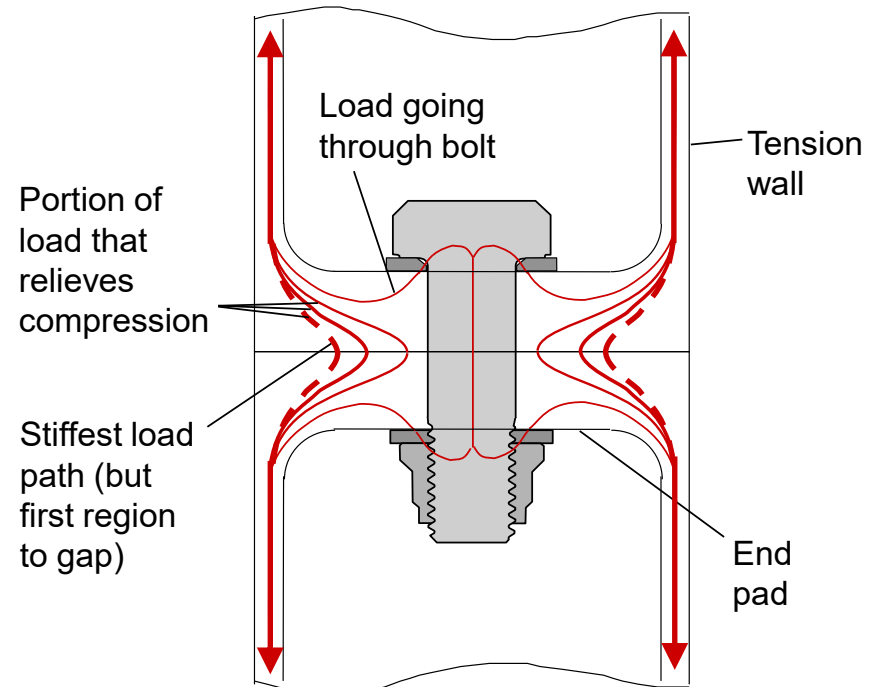

**The bolt load path is in parallel with the stiffer load path of clamped material. Bolt stiffness contributes little to joint stiffness, especially at low levels of applied load relative to preload.**

## Appendix A: Finite Element Modeling of Bolted Joints Simple Model of a Well-Designed Tension Joint

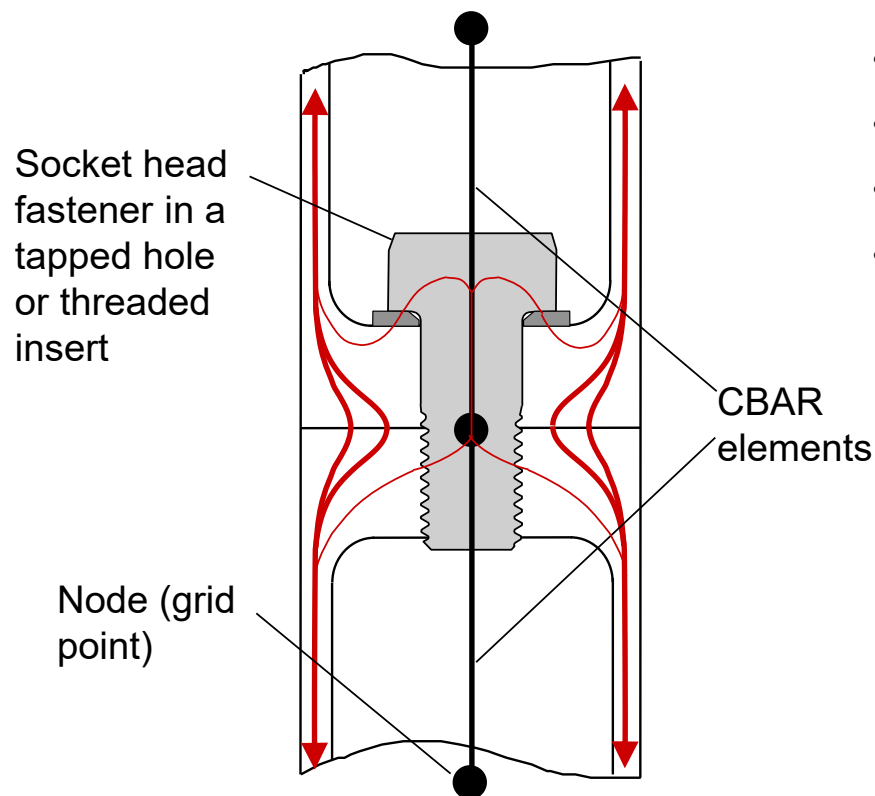

- Bolt close to tension walls
- Thick end pads
- High preload
- Result: negligible loss of stiffness; joint is as stiff as the attached members

**No additional model detail is needed in this case.**

## Appendix A: Finite Element Modeling of Bolted Joints Suggested Method of Modeling a Tension Joint

For a joint with thinner end pads or further spaced tension walls, it becomes more important to represent the shear and bending stiffness of the end pads.

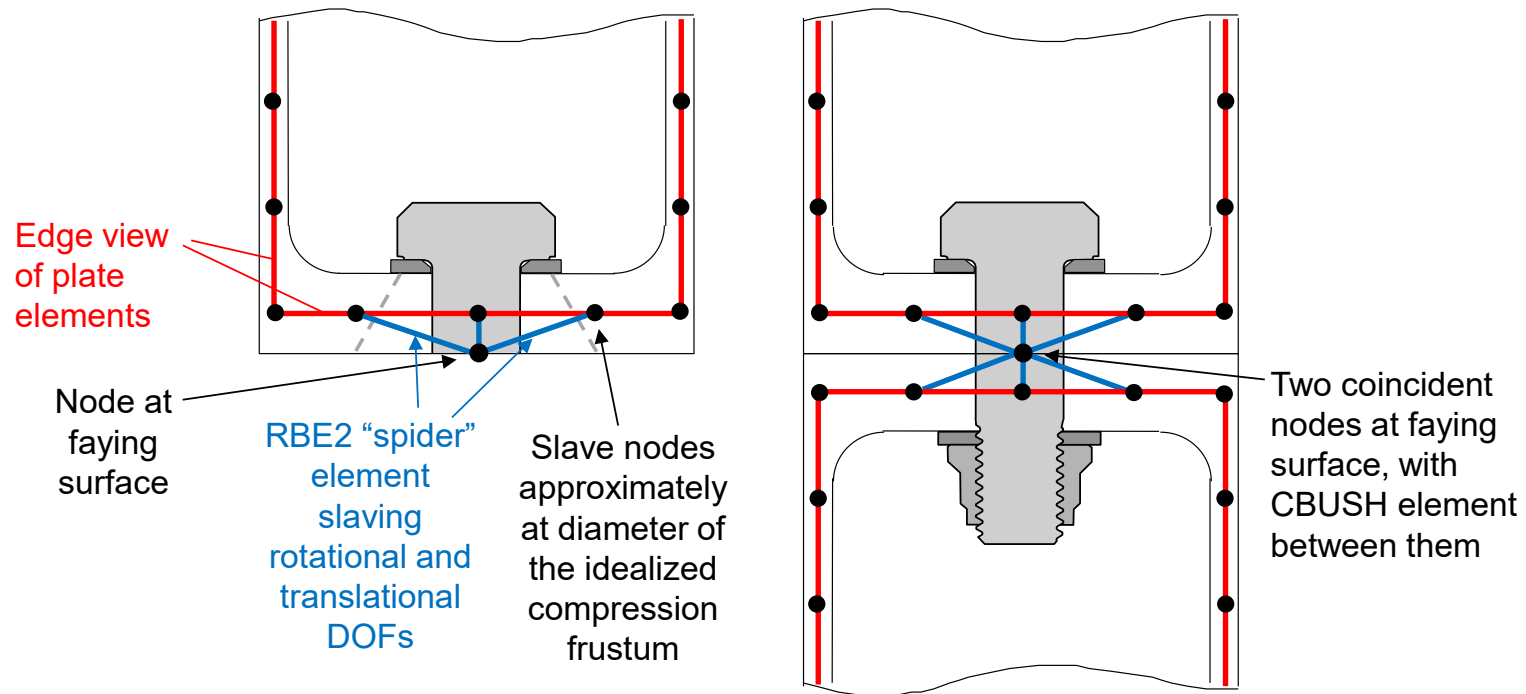

As an alternative to the method shown above, place the nodes for the end-pad plate elements at the faying surface, and then offset the elements to the centers of the end pads. With this approach, the RBE2 elements are in the plane of the faying surface.

## Appendix A: Finite Element Modeling of Bolted Joints What About Dynamic Reversed (Tension-Compression) Loading?

The model shown on the previous page is based on representing stiffness under applied tension.

But, under dynamic loading, most joints cycle between tension and compression.

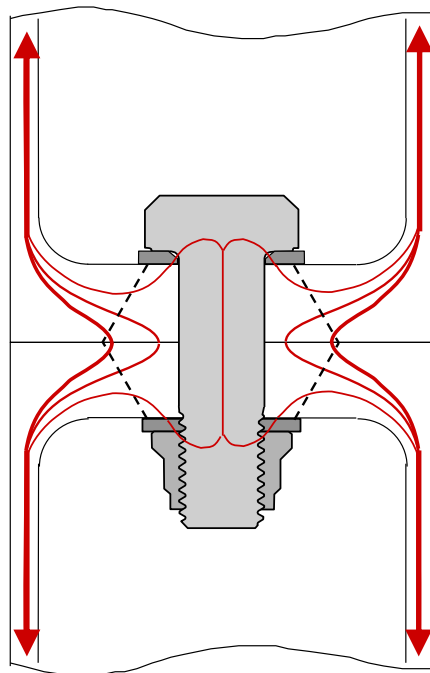

Applied tension

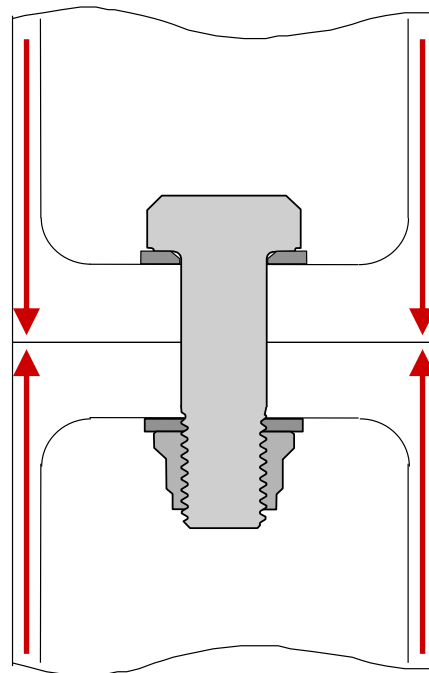

Applied compression (stiffer)

For the best stiffness representation for dynamic loads analysis, we should try to model the average stiffness between tension and compression.

Remember from Sec. 3: One of the goals in structural design is to minimize the difference in stiffness between tension and compression.

## Appendix A: Finite Element Modeling of Bolted Joints Adjusting the Model for Dynamic Loading

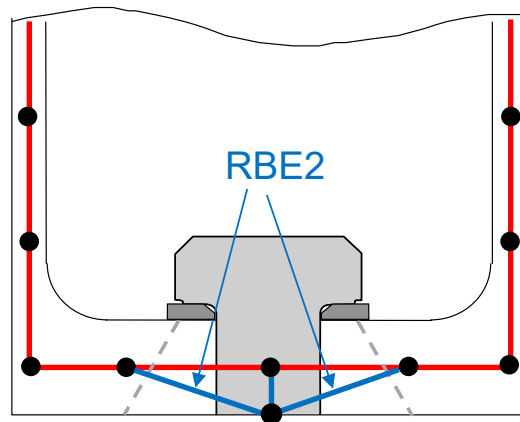

Instead of modeling the tensile load path only, with RBE2 slave nodes based on the assumed frustums, ...

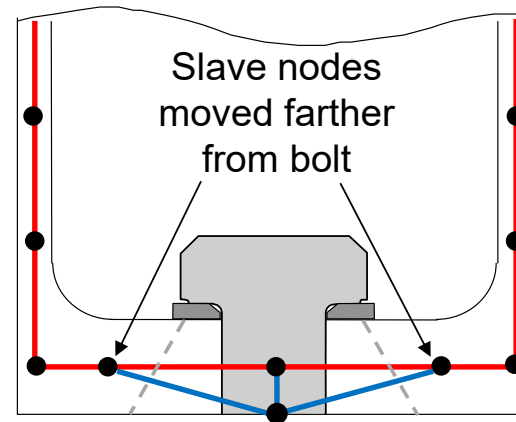

... move the slave nodes outboard somewhat to get a better representation of average tension/compression stiffness.

## Appendix A: Finite Element Modeling of Bolted Joints

### Modeling a Preloaded Shear Joint

For a model that will be used for dynamic analysis or to predict load distribution, we usually want the model to simulate load transfer by friction rather than by shear in the fasteners.

- Even though our analysis criteria may dictate that we calculate strength margins of safety for ultimate strength when discounting friction.

As noted previously, the design team should try to minimize nonlinearity so that linear-elastic models adequately predict loads and load distribution.

- Shear joints with oversized bolt holes (almost always the case, unless holes are match drilled and reamed), should have high preload or features such as shear pins.

For cases in which high preload or use of shear pins is not practical, such as for many lug-and-clevis joints and when clamping nonmetallic parts, bolt holes should be match drilled and reamed, with minimal oversize.

- In such cases, it can become more important to model bolt stiffness for shear loading.
- But such stiffness values should be based on test or on detailed models using solid elements rather than on simple beam approximations with bolt length determined by the distance between centerlines of the load-bearing plates—an approach that overly reduces stiffness.

## Appendix A: Finite Element Modeling of Bolted Joints Modeling a Preloaded Shear Joint (continued)

Same as for tension joints, we can model a shear joint with plate elements, rigid elements, and CBUSH elements.

The same basic modeling approach applies: CBUSH between coincident nodes, and RBE2s to nodes at a circumference representing the clamped material.

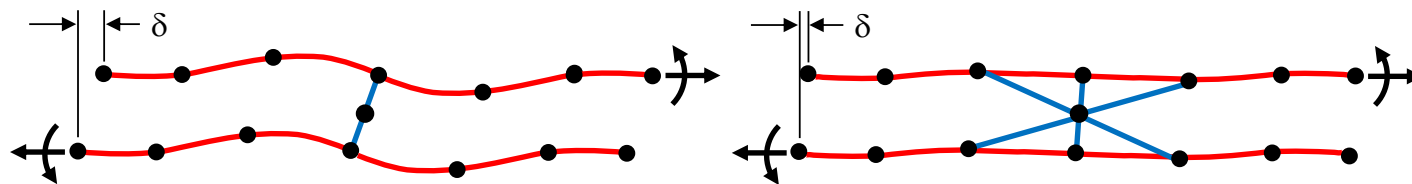
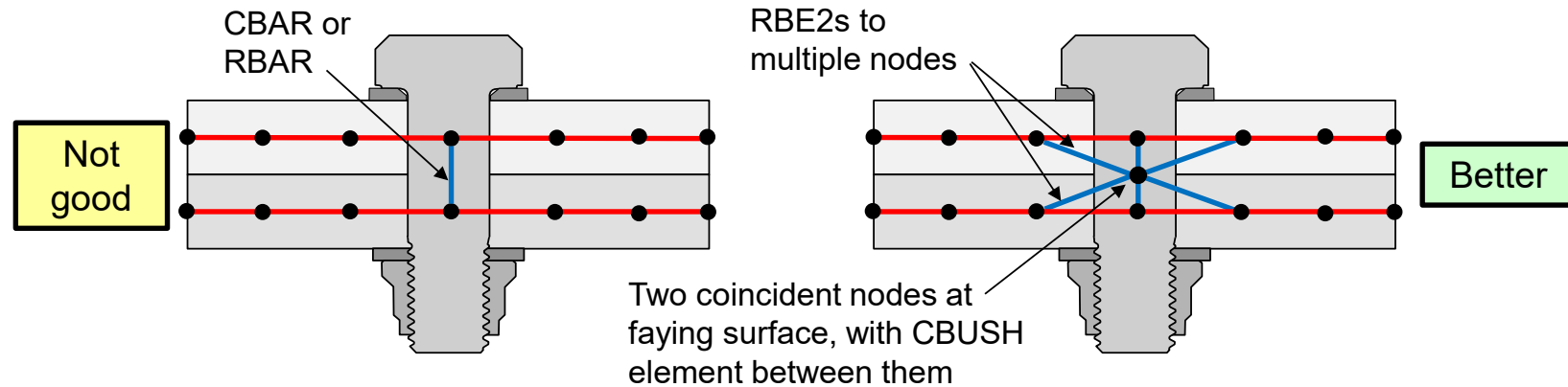

Using a stiff CBAR or an RBAR to a single node in the plate mesh, at the bolt location, leads to an overly flexible model.

More realistic.

## Appendix A: Finite Element Modeling of Bolted Joints

### CBUSH Stiffness for the Bolt Itself

Given that the bolt contributes little to the stiffness of a preloaded joint, the appropriate stiffness for the CBUSH element should be ...

- one that is high enough to have negligible effect on the predicted modes of vibration (negligible strain energy in the CBUSH element)
- but that is not so high that it will ill-condition the model's global stiffness matrix.
  - With double-precision computation, diagonal terms in the FEM's stiffness matrix should be within about  $1 \times 10^{12}$  of each other in order to avoid affecting accuracy to three significant figures.

You might start with something like  $1 \times 10^7$  lb/in for translational spring rates and  $1 \times 10^8$  in-lb/rad for rotational spring rates when representing a bolt. (Remember: One radian is a big angle!)

Calculate modes of vibration, and then increase the above spring rates by an order of magnitude to see how much the modal frequencies change. If the change is less than 1%, you've probably found a good set of spring rates

**Remember: In the actual joint, the bolt is a load path that is in parallel with the clamped material.**

**In your FEM, the bolt is most likely in series with other springs, so low stiffness for the bolt element has a big, unrealistic effect.**

## Appendix A: Finite Element Modeling of Bolted Joints Avoiding Over-Constraint

With multiple fasteners in a joint, we need to be aware that the use of RBE2 elements as described above can overly constrain a model.

For example, consider the C-channel ring shown below. This ring has 24 evenly spaced bolt holes on each flange.

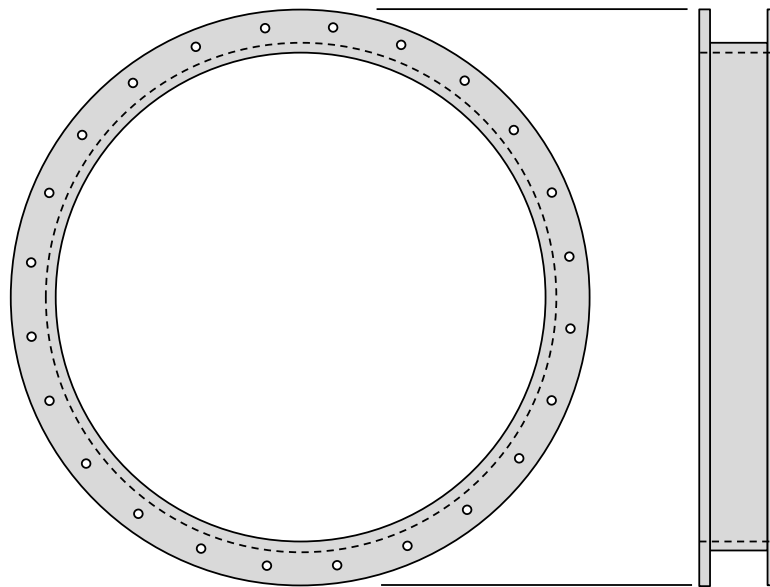

(continued)

## Appendix A: Finite Element Modeling of Bolted Joints Avoiding Over-Constraint, Ring Example (continued)

A reasonable model of the ring shown on the previous page:

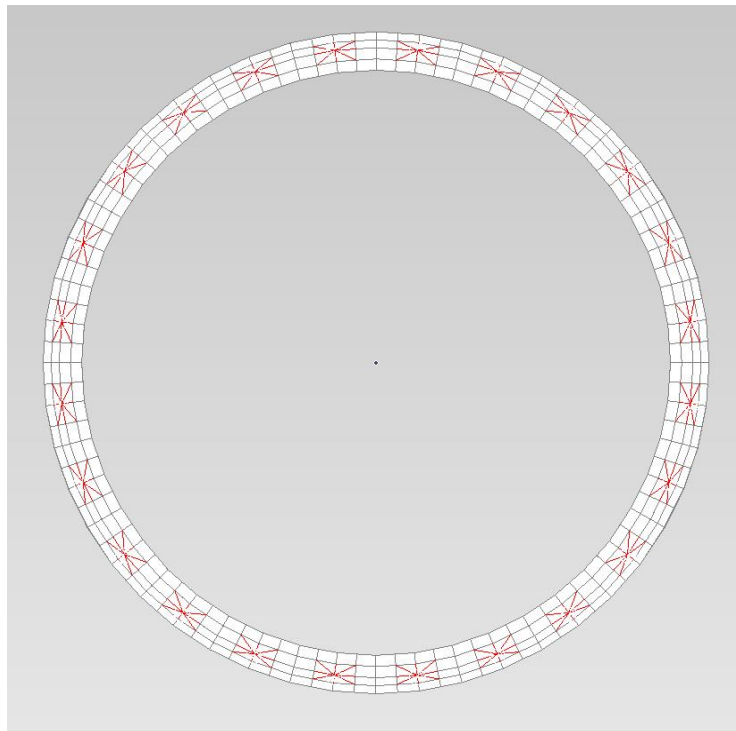

RBE2 spiders at bolt locations shown in red

Problem: If this model interfaces with one or more models that can ovalize or warp out of plane, the RBE2s in the model shown at right can overly rigidize the ring for such distortion.

For example, opposing radial forces, 180° apart, would cause this model to distort significantly less than if the RBE2s were removed.

(continued)

## Appendix A: Finite Element Modeling of Bolted Joints Avoiding Over-Constraint, Ring Example (continued)

Improvement: Free up selected slave DOFs.  
Example:

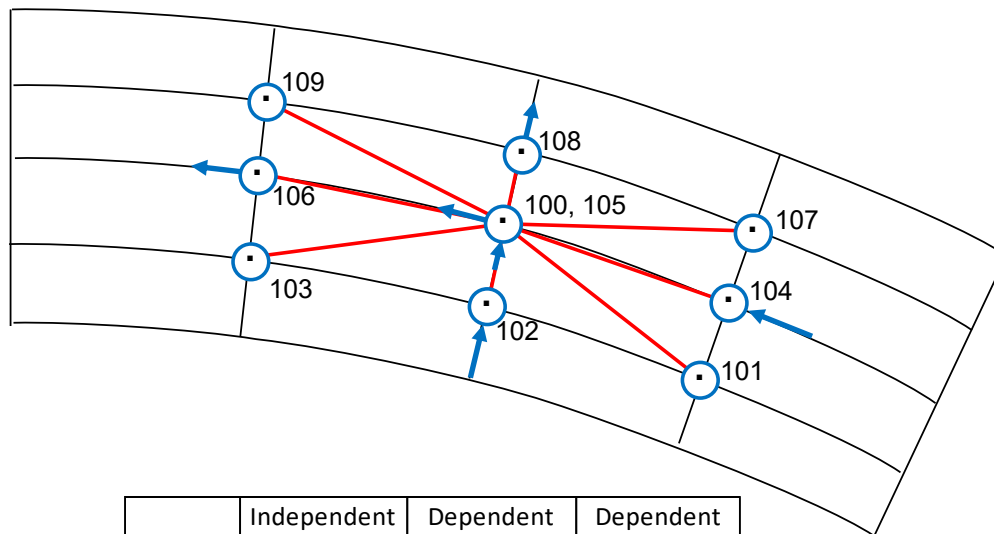

RBE2	Independent Node	Dependent Nodes	Dependent DOFs
1	100	102, 105, 108	1 ( R )
2	100	104 - 106	2 ( $\theta$ )
3	100	101 - 109	3 ( Z ), 4, 5, 6

(cylindrical coordinate system)

The slaved DOFs shown here don't fully prevent overly rigidizing the model for certain types of loading, but they improve accuracy when compared to slaving all DOFs.

Experiment with different schemes, aiming to match overall ring stiffness from a model without any RBE2s.

**Appendix B**

**Design Tables for  
Preliminary Bolt Sizing Based on  
NASA-STD-5020B Analysis  
Criteria**

Permission is granted by Instar for anyone to freely copy, distribute, and print this material, but only in its unaltered form. This section may be separately copied or printed, but only in its entirety, including this page and with headers and footers intact. Unaltered individual figures and tables and portions of text may be copied or used, but only with text in quotes and with the following statement "Source: Design and Analysis of Bolted Joints (DABJ) course book, Thomas P. Sarafin, Instar Engineering and Consulting, Inc. Reproduced with permission." The date of last revision also should be included in the reference. If you have questions, contact [tom.sarafin@instarengineering.com](mailto:tom.sarafin@instarengineering.com).

## Appendix B: Design Tables

# Objectives and Introduction

The goal of this section is to show how to work backwards from the NASA-STD-5020B analysis criteria and generate tables that enable easy selection of bolt size needed for a particular application.

You will need the following in order to select a bolt size with tables such as these:

- Definition of materials for bolts and fittings (joint members)
- Applicable factor of safety for separation analysis
- Target (nominal) or maximum initial preload, or installation torque values along with a test-substantiated nominal nut factor
- Preload variation,  $\Gamma$  (either assumed or derived from test data; see Sec. 9A.1, herein)
- Number of bolts in the joint (when unknown, it's conservative to assume one bolt)
- Limit tensile load and design ultimate shear load acting on the highest-loaded bolt (see Sec. 4)
- Approximate temperature range for the loading event of concern (e.g., launch)

These tables do not substitute for detailed analysis, but bolt sizes selected from these tables will most likely meet the analysis criteria if certain constraints are met.

**Let's start with an explanation of how to generate such design tables.**

## Appendix B: Design Tables Setting Up a Spreadsheet

1. Set up a spreadsheet of the form shown below.
2. For a given type of bolt, start by tabulating the bolt's basic dimensions and cross-sectional areas for different diameters, as shown in Table 2-1.
  - Nominal diameter, full-diameter shear area, minor-diameter area, and tensile stress area
3. Set up the spreadsheet to calculate the remaining variables, based on equations shown on the following pages.

Bolt size	Nominal diameter, $D$	Full-diameter shear area, $A_s$	Minor-diameter area, $A_m$	Tensile stress area, $A_t$	Allowable ultimate tensile load, $P_{tu\text{-allow}}$	Allowable yield tensile load, $P_{ty\text{-allow}}$	Nominal initial preload, $P_{pi\text{-nom}}$	Maximum preload, $P_{p\text{-max}}$	Minimum preload, $P_{p\text{-min}}$	Allowable limit tensile load, $P_{tL\text{-allow}}$	Allowable ultimate shear load, $P_{su\text{-allow}}$	
											Threads not in shear plane (floating fasteners with grip)	Threads in shear plane (fixed fasteners)

## Appendix B: Design Tables

# Assumptions Made to Generate the Equations I Used

- Preload does not reduce ultimate strength,
  - which is the case for most all-metallic joints (as seen in Secs. 8 and 9).
- The nut, threaded insert, or tapped hole is at least as strong as the bolt and thus can fully develop the bolt's tensile strength.
- The bolt is of a type that is intended for tensile loading.
  - Failure would be through the cross section at the threads rather than at the head.
- Temperature during the loading event of concern stays within 30°F of room temperature.
- Bolts are made of A-286, and the joint members are made of an aluminum alloy.
- Preload is controlled by torque, and torque is specified as “above running torque” (see p. 9-10), with a tolerance no greater than +/-5%.
- Bolt bending is negligible and thus does not affect strength.
- The gapping criterion is that the design separation load shall not exceed the minimum preload (the approach I recommended in Sec. 9 for joints that don't have to maintain a seal).

**For any other situations, modify the equations and method accordingly in order to generate similar design tables.**

## Appendix B: Design Tables

# Equations for the Spreadsheets

Allowable ultimate tensile load, $P_{tu\text{-allow}}$	Allowable yield tensile load, $P_{ty\text{-allow}}$	Nominal initial preload, $P_{pi\text{-nom}}$	Maximum preload, $P_{p\text{-max}}$	Minimum preload, $P_{p\text{-min}}$	Allowable limit tensile load, $P_{tL\text{-allow}}$	Allowable ultimate shear load, $P_{su\text{-allow}}$	
						Threads not in shear plane (floating fasteners with grip)	Threads in shear plane (fixed fasteners)

$$P_{tu\text{-allow}} = F_{tu} A_t \quad (\text{Eq. 5.1})$$

$$P_{ty\text{-allow}} = \left( \frac{F_{ty}}{F_{tu}} \right) P_{tu\text{-allow}} \quad (\text{Eq. 18; Sec. 9 herein})$$

$$P_{tL\text{-allow}} = \frac{P_{p\text{-min}}}{FF_{sep} \cdot FS_{sep}} \quad (\text{Eq. B.1, based on Eq. 19})$$

$$P_{su\text{-allow}} = \frac{F_{su} \pi D^2}{4} \quad \text{for threads not in shear plane} \quad (\text{Eq. 12})$$

$$P_{su\text{-allow}} = F_{su} A_m \quad \text{for threads in shear plane} \quad (\text{Eq. 13})$$

$$P_{pi\text{-nom}}, P_{p\text{-max}}, \text{ and } P_{p\text{-min}} \Rightarrow \text{ see next page}$$

where

$F_{tu}$  = allowable ultimate tensile strength for bolt

$F_{ty}$  = allowable tensile yield stress for bolt

$F_{su}$  = allowable ultimate shear stress

$D$  = nominal bolt diameter

$A_t$  = tensile stress area

$A_m$  = minor-diameter area

$FF_{sep}$  = separation fitting factor

$FS_{sep}$  = separation factor of safety

## Appendix B: Design Tables

### Equations for the Spreadsheets, continued

Several NASA centers prefer to set torque values such that the nominal initial preload is 65% of the bolt's allowable yield tensile load. In such a case, ...

$$P_{pi-nom} = 0.65P_{ty-allow} \quad P_{p-max} = 1.05(1.03)(1 + \Gamma)P_{pi-nom} \quad (\text{Eq. B.2})$$

assuming torque is specified as "above running torque," with a +/-5% tolerance

to account for thermal effects (A-286 bolt clamping aluminum when  $\Delta T < 30^\circ \text{ F}$ )\*

Another philosophy, when bolt yielding is not detrimental, is to torque such that the maximum initial preload is 75% of the bolt's allowable ultimate tensile load. In such a case, ...

maximum initial preload,  $P_{pi-max} = 0.75P_{tu-allow}$

$$P_{pi-nom} = \frac{P_{pi-max}}{1.05(1 + \Gamma)} \quad P_{p-max} = 1.05(1.03)(1 + \Gamma)P_{pi-nom} \quad (\text{Eq. B.3})$$

In either case, ...

$$P_{p-min} = 0.95(0.95)(0.95) \left( 1 - \frac{\Gamma}{\sqrt{n_f}} \right) P_{pi-nom} \quad (\text{Eq. B.4})$$

accounting for assumed +/-5% tolerance on torque

Assuming 5% relaxation

to account for thermal effects (A-286 bolt clamping aluminum when  $\Delta T < 30^\circ \text{ F}$ )\*

where  
 $\Gamma$  = preload variation  
 $n_f$  = number of bolts in the joint

\*Effect of temperature change is based on Tables 8-4 and 8-5.

## Appendix B: Design Tables

# Typical Driving Parameters

Allowable ultimate tensile load, $P_{tu\text{-allow}}$	Allowable yield tensile load, $P_{ty\text{-allow}}$	Nominal initial preload, $P_{pi\text{-nom}}$	Maximum preload, $P_{p\text{-max}}$	Minimum preload, $P_{p\text{-min}}$	Allowable limit tensile load, $P_{tL\text{-allow}}$	Allowable ultimate shear load, $P_{su\text{-allow}}$	
						Threads not in shear plane (floating fasteners with grip)	Threads in shear plane (fixed fasteners)

**Bolt size is typically driven by either  $P_{tL\text{-allow}}$  (for tension joints, based on the separation criterion), or by  $P_{su\text{-allow}}$  (for shear joints).**

**For bolts under significant tension and shear acting simultaneously, to account for interaction we may need to move up one size from what  $P_{su\text{-allow}}$  in the table tells us.**

Hypothetical example:	Design loads:	Allowable loads for 1/4"-dia bolt:
	Limit tensile load, $P_{tL} = 2000$ lb	$P_{tL\text{-allow}} = 2200$ lb
	Design ult. tensile load, $P_{tu} = 3220$ lb	$P_{tu\text{-allow}} = 6000$ lb
	Design ult. shear load, $P_{su} = 3000$ lb	$P_{su\text{-allow}} = 3100$ lb

Based solely on the allowable loads, a 1/4" bolt would be acceptable, but we should use a 5/16" bolt to provide margin for the tension-shear interaction criteria, which are not addressed in the tables.

## Appendix B: Design Tables

# Design Tables for Selected Situations

The following pages contain design tables generated with the provided equations. These tables are for joints that meet the assumptions stated on page B-4, and ...

- A-286 bolts, from sizes #4 through ½” diameter
- UNRF threads for #4 - #10 (consistent with NAS 1351 socket head cap screws) and UNJF threads for ¼” – ½” diameter
- Preload variation,  $\Gamma$ , is 0.25 lubricated, 0.35 not lubricated.
- Joints that are subject to a 1.0 factor of safety and a 1.0 fitting factor for separation (typically meaning they are not separation critical)

Eight tables are presented, with the following combinations of variables:

Table No.	Number bolts in joint		Preload philosophy		Lubricated?	
	1	4	$P_{p\ i-nom} = 0.65P_{ty\ -allow}$	$P_{p\ i-max} = 0.75P_{tu\ -allow}$	Yes	No
1	x		x		x	
2	x		x			x
3	x			x	x	
4	x			x		x
5		x	x		x	
6		x	x			x
7		x		x	x	
8		x		x		x



# Design Table 1

A-286 bolts, 160 ksi; retaining device (nut, tapped hole, threaded insert) can fully develop the bolt's ultimate tensile strength Units: lb, in  
 UNRF threads for #4 - #10 (NAS 1351 socket head cap screws), and UNJF threads for 1/4" - 1/2" diameter  
 Not separation critical; separation factor of safety times fitting factor = 1.0 Aluminum joint members  
 Number of bolts in joint,  $n_f = 1$  Temperature stays within 30° F of room temp.  
 Nominal initial preload = 65% of allowable yield tensile load  
 Lubricated;  $\Gamma = 0.25$  Variation for minimum preload,  $\Gamma \div \text{sqrt}(n_f) = 0.25$   
 Allowable stresses for bolt material:  
 $F_{tu} = 160$  ksi Torque is specified as "above running torque," with a tolerance of +/-5%  
 $F_{ty} = 120$  ksi  
 $F_{su} = 95$  ksi

Bolt size	Nominal diameter, $D$	Full-diameter shear area, $A_s$	Minor-diameter area, $A_m$	Tensile stress area, $A_t$	Allowable ultimate tensile load, $P_{tu\text{-allow}}$	Allowable yield tensile load, $P_{ty\text{-allow}}$	Nominal initial preload, $P_{pi\text{-nom}}$	Maximum preload, $P_{p\text{-max}}$	Minimum preload, $P_{p\text{-min}}$	Allowable limit tensile load, $P_{tl\text{-allow}}$	Allowable ultimate shear load, $P_{su\text{-allow}}$	
											Threads not in shear plane (floating fasteners with grip)	Threads in shear plane (fixed fasteners)
#4	0.112	0.00985	0.00566	0.00660	1056	792	515	696	331	331	936	538
#6	0.138	0.0150	0.00874	0.01014	1622	1217	791	1069	509	509	1421	830
#8	0.164	0.0211	0.01285	0.01473	2360	1770	1151	1555	740	740	2010	1221
#10	0.190	0.0284	0.0175	0.0200	3200	2400	1560	2109	1003	1003	2690	1660
1/4	0.250	0.0491	0.0327	0.0404	6460	4850	3150	4258	2026	2026	4660	3110
5/16	0.313	0.0767	0.0527	0.0640	10240	7680	4990	6746	3210	3210	7290	5010
3/8	0.375	0.110	0.0811	0.0951	15200	11400	7410	10017	4760	4760	10490	7700
7/16	0.438	0.150	0.1096	0.1288	20600	15500	10080	13627	6480	6480	14280	10410
1/2	0.500	0.196	0.1493	0.1717	27500	20600	13390	18102	8610	8610	18650	14180



## Design Table 2

A-286 bolts, 160 ksi; retaining device (nut, tapped hole, threaded insert) can fully develop the bolt's ultimate tensile strength											Units: lb, in	
UNRF threads for #4 - #10 (NAS 1351 socket head cap screws), and UNJF threads for 1/4" - 1/2" diameter												
Not separation critical; separation factor of safety times fitting factor = 1.0											Aluminum joint members	
Number of bolts in joint, $n_f = 1$											Temperature stays within 30° F of room temp.	
Nominal initial preload = 65% of allowable yield tensile load												
Not lubricated; $\Gamma = 0.35$				Variation for minimum preload, $\Gamma \div \text{sqrt}(n_f) =$					0.35			
Allowable stresses for bolt material:												
$F_{tu} =$		160 ksi		Torque is specified as "above running torque," with a tolerance of +/-5%								
$F_{ty} =$		120 ksi										
$F_{su} =$		95 ksi										

Bolt size	Nominal diameter, $D$	Full-diameter shear area, $A_s$	Minor-diameter area, $A_m$	Tensile stress area, $A_t$	Allowable ultimate tensile load, $P_{tu\text{-allow}}$	Allowable yield tensile load, $P_{ty\text{-allow}}$	Nominal initial preload, $P_{pi\text{-nom}}$	Maximum preload, $P_{p\text{-max}}$	Minimum preload, $P_{p\text{-min}}$	Allowable limit tensile load, $P_{tL\text{-allow}}$	Allowable ultimate shear load, $P_{su\text{-allow}}$	
											Threads not in shear plane (floating fasteners with grip)	Threads in shear plane (fixed fasteners)
#4	0.112	0.00985	0.00566	0.00660	1056	792	515	752	287	287	936	538
#6	0.138	0.0150	0.00874	0.01014	1622	1217	791	1155	441	441	1421	830
#8	0.164	0.0211	0.01285	0.01473	2360	1770	1151	1680	641	641	2010	1221
#10	0.190	0.0284	0.0175	0.0200	3200	2400	1560	2278	869	869	2690	1660
1/4	0.250	0.0491	0.0327	0.0404	6460	4850	3150	4599	1755	1755	4660	3110
5/16	0.313	0.0767	0.0527	0.0640	10240	7680	4990	7286	2780	2780	7290	5010
3/8	0.375	0.110	0.0811	0.0951	15200	11400	7410	10819	4130	4130	10490	7700
7/16	0.438	0.150	0.1096	0.1288	20600	15500	10080	14717	5620	5620	14280	10410
1/2	0.500	0.196	0.1493	0.1717	27500	20600	13390	19550	7460	7460	18650	14180



## Design Table 3

A-286 bolts, 160 ksi; retaining device (nut, tapped hole, threaded insert) can fully develop the bolt's ultimate tensile strength											Units: lb, in	
UNRF threads for #4 - #10 (NAS 1351 socket head cap screws), and UNJF threads for 1/4" - 1/2" diameter												
Not separation critical; separation factor of safety times fitting factor = 1.0											Aluminum joint members	
Number of bolts in joint, $n_f = 1$											Temperature stays within 30° F of room temp.	
Maximum initial preload = 75% of allowable ultimate tensile load												
Lubricated; $\Gamma = 0.25$											Variation for minimum preload, $\Gamma \div \text{sqrt}(n_f) = 0.25$	
Allowable stresses for bolt material:												
$F_{tu} = 160$ ksi											Torque is specified as "above running torque," with a tolerance of +/-5%	
$F_{ty} = 120$ ksi												
$F_{su} = 95$ ksi												
Bolt size	Nominal diameter, $D$	Full-diameter shear area, $A_s$	Minor-diameter area, $A_m$	Tensile stress area, $A_t$	Allowable ultimate tensile load, $P_{tu\text{-allow}}$	Allowable yield tensile load, $P_{ty\text{-allow}}$	Nominal initial preload, $P_{pi\text{-nom}}$	Maximum preload, $P_{p\text{-max}}$	Minimum preload, $P_{p\text{-min}}$	Allowable limit tensile load, $P_{tL\text{-allow}}$	Allowable ultimate shear load, $P_{su\text{-allow}}$	
											Threads not in shear plane (floating fasteners with grip)	Threads in shear plane (fixed fasteners)
#4	0.112	0.00985	0.00566	0.00660	1056	792	603	816	388	388	936	538
#6	0.138	0.0150	0.00874	0.01014	1622	1217	927	1253	596	596	1421	830
#8	0.164	0.0211	0.01285	0.01473	2360	1770	1349	1823	867	867	2010	1221
#10	0.190	0.0284	0.0175	0.0200	3200	2400	1829	2472	1176	1176	2690	1660
1/4	0.250	0.0491	0.0327	0.0404	6460	4850	3691	4990	2374	2374	4660	3110
5/16	0.313	0.0767	0.0527	0.0640	10240	7680	5851	7910	3760	3760	7290	5010
3/8	0.375	0.110	0.0811	0.0951	15200	11400	8686	11742	5590	5590	10490	7700
7/16	0.438	0.150	0.1096	0.1288	20600	15500	11771	15914	7570	7570	14280	10410
1/2	0.500	0.196	0.1493	0.1717	27500	20600	15714	21244	10100	10100	18650	14180



## Design Table 4

A-286 bolts, 160 ksi; retaining device (nut, tapped hole, threaded insert) can fully develop the bolt's ultimate tensile strength											Units: lb, in	
UNRF threads for #4 - #10 (NAS 1351 socket head cap screws), and UNJF threads for 1/4" - 1/2" diameter												
Not separation critical; separation factor of safety times fitting factor = 1.0											Aluminum joint members	
Number of bolts in joint, $n_f = 1$											Temperature stays within 30° F of room temp.	
Maximum initial preload = 75% of allowable ultimate tensile load												
Not lubricated; $\Gamma = 0.35$											Variation for minimum preload, $\Gamma \div \text{sqrt}(n_f) = 0.35$	
Allowable stresses for bolt material:												
$F_{tu} = 160$ ksi											Torque is specified as "above running torque," with a tolerance of +/-5%	
$F_{ty} = 120$ ksi												
$F_{su} = 95$ ksi												
Bolt size	Nominal diameter, $D$	Full-diameter shear area, $A_s$	Minor-diameter area, $A_m$	Tensile stress area, $A_t$	Allowable ultimate tensile load, $P_{tu\text{-allow}}$	Allowable yield tensile load, $P_{ty\text{-allow}}$	Nominal initial preload, $P_{pi\text{-nom}}$	Maximum preload, $P_{p\text{-max}}$	Minimum preload, $P_{p\text{-min}}$	Allowable limit tensile load, $P_{tL\text{-allow}}$	Allowable ultimate shear load, $P_{su\text{-allow}}$	
											Threads not in shear plane (floating fasteners with grip)	Threads in shear plane (fixed fasteners)
#4	0.112	0.00985	0.00566	0.00660	1056	792	559	816	311	311	936	538
#6	0.138	0.0150	0.00874	0.01014	1622	1217	858	1253	478	478	1421	830
#8	0.164	0.0211	0.01285	0.01473	2360	1770	1249	1823	696	696	2010	1221
#10	0.190	0.0284	0.0175	0.0200	3200	2400	1693	2472	944	944	2690	1660
1/4	0.250	0.0491	0.0327	0.0404	6460	4850	3418	4990	1905	1905	4660	3110
5/16	0.313	0.0767	0.0527	0.0640	10240	7680	5418	7910	3020	3020	7290	5010
3/8	0.375	0.110	0.0811	0.0951	15200	11400	8042	11742	4480	4480	10490	7700
7/16	0.438	0.150	0.1096	0.1288	20600	15500	10899	15914	6070	6070	14280	10410
1/2	0.500	0.196	0.1493	0.1717	27500	20600	14550	21244	8110	8110	18650	14180



## Design Table 5

A-286 bolts, 160 ksi; retaining device (nut, tapped hole, threaded insert) can fully develop the bolt's ultimate tensile strength											Units: lb, in	
UNRF threads for #4 - #10 (NAS 1351 socket head cap screws), and UNJF threads for 1/4" - 1/2" diameter												
Not separation critical; separation factor of safety times fitting factor = 1.0											Aluminum joint members	
Number of bolts in joint, $n_f = 4$											Temperature stays within 30° F of room temp.	
Nominal initial preload = 65% of allowable yield tensile load												
Lubricated; $\Gamma = 0.25$											Variation for minimum preload, $\Gamma \div \text{sqrt}(n_f) = 0.125$	
Allowable stresses for bolt material:												
$F_{tu} = 160$ ksi											Torque is specified as "above running torque," with a tolerance of +/-5%	
$F_{ty} = 120$ ksi												
$F_{su} = 95$ ksi												
Bolt size	Nominal diameter, $D$	Full-diameter shear area, $A_s$	Minor-diameter area, $A_m$	Tensile stress area, $A_t$	Allowable ultimate tensile load, $P_{tu\text{-allow}}$	Allowable yield tensile load, $P_{ty\text{-allow}}$	Nominal initial preload, $P_{pi\text{-nom}}$	Maximum preload, $P_{p\text{-max}}$	Minimum preload, $P_{p\text{-min}}$	Allowable limit tensile load, $P_{tl\text{-allow}}$	Allowable ultimate shear load, $P_{su\text{-allow}}$	
											Threads not in shear plane (floating fasteners with grip)	Threads in shear plane (fixed fasteners)
#4	0.112	0.00985	0.00566	0.00660	1056	792	515	696	386	386	936	538
#6	0.138	0.0150	0.00874	0.01014	1622	1217	791	1069	593	593	1421	830
#8	0.164	0.0211	0.01285	0.01473	2360	1770	1151	1555	863	863	2010	1221
#10	0.190	0.0284	0.0175	0.0200	3200	2400	1560	2109	1170	1170	2690	1660
1/4	0.250	0.0491	0.0327	0.0404	6460	4850	3150	4258	2363	2363	4660	3110
5/16	0.313	0.0767	0.0527	0.0640	10240	7680	4990	6746	3740	3740	7290	5010
3/8	0.375	0.110	0.0811	0.0951	15200	11400	7410	10017	5560	5560	10490	7700
7/16	0.438	0.150	0.1096	0.1288	20600	15500	10080	13627	7560	7560	14280	10410
1/2	0.500	0.196	0.1493	0.1717	27500	20600	13390	18102	10050	10050	18650	14180



## Design Table 6

A-286 bolts, 160 ksi; retaining device (nut, tapped hole, threaded insert) can fully develop the bolt's ultimate tensile strength											Units: lb, in	
UNRF threads for #4 - #10 (NAS 1351 socket head cap screws), and UNJF threads for 1/4" - 1/2" diameter												
Not separation critical; separation factor of safety times fitting factor = 1.0											Aluminum joint members	
Number of bolts in joint, $n_f = 4$											Temperature stays within 30° F of room temp.	
Nominal initial preload = 65% of allowable yield tensile load												
Not lubricated; $\Gamma = 0.35$											Variation for minimum preload, $\Gamma \div \text{sqrt}(n_f) = 0.175$	
Allowable stresses for bolt material:												
$F_{tu} = 160$ ksi											Torque is specified as "above running torque," with a tolerance of +/-5%	
$F_{ty} = 120$ ksi												
$F_{su} = 95$ ksi												
Bolt size	Nominal diameter, $D$	Full-diameter shear area, $A_s$	Minor-diameter area, $A_m$	Tensile stress area, $A_t$	Allowable ultimate tensile load, $P_{tu\text{-allow}}$	Allowable yield tensile load, $P_{ty\text{-allow}}$	Nominal initial preload, $P_{pi\text{-nom}}$	Maximum preload, $P_{p\text{-max}}$	Minimum preload, $P_{p\text{-min}}$	Allowable limit tensile load, $P_{tl\text{-allow}}$	Allowable ultimate shear load, $P_{su\text{-allow}}$	
											Threads not in shear plane (floating fasteners with grip)	Threads in shear plane (fixed fasteners)
#4	0.112	0.00985	0.00566	0.00660	1056	792	515	752	364	364	936	538
#6	0.138	0.0150	0.00874	0.01014	1622	1217	791	1155	559	559	1421	830
#8	0.164	0.0211	0.01285	0.01473	2360	1770	1151	1680	814	814	2010	1221
#10	0.190	0.0284	0.0175	0.0200	3200	2400	1560	2278	1103	1103	2690	1660
1/4	0.250	0.0491	0.0327	0.0404	6460	4850	3150	4599	2228	2228	4660	3110
5/16	0.313	0.0767	0.0527	0.0640	10240	7680	4990	7286	3530	3530	7290	5010
3/8	0.375	0.110	0.0811	0.0951	15200	11400	7410	10819	5240	5240	10490	7700
7/16	0.438	0.150	0.1096	0.1288	20600	15500	10080	14717	7130	7130	14280	10410
1/2	0.500	0.196	0.1493	0.1717	27500	20600	13390	19550	9470	9470	18650	14180



## Design Table 7

A-286 bolts, 160 ksi; retaining device (nut, tapped hole, threaded insert) can fully develop the bolt's ultimate tensile strength											Units: lb, in	
UNRF threads for #4 - #10 (NAS 1351 socket head cap screws), and UNJF threads for 1/4" - 1/2" diameter												
Not separation critical; separation factor of safety times fitting factor =								1.0		Aluminum joint members		
Number of bolts in joint, $n_f = 4$								Temperature stays within 30° F of room temp.				
Maximum initial preload = 75% of allowable ultimate tensile load												
Lubricated; $\Gamma =$		0.25		Variation for minimum preload, $\Gamma \div \text{sqrt}(n_f) =$					0.125			
Allowable stresses for bolt material:												
$F_{tu} =$		160 ksi		Torque is specified as "above running torque," with a tolerance of +/-5%								
$F_{ty} =$		120 ksi										
$F_{su} =$		95 ksi										
Bolt size	Nominal diameter, $D$	Full-diameter shear area, $A_s$	Minor-diameter area, $A_m$	Tensile stress area, $A_t$	Allowable ultimate tensile load, $P_{tu\text{-allow}}$	Allowable yield tensile load, $P_{ty\text{-allow}}$	Nominal initial preload, $P_{pi\text{-nom}}$	Maximum preload, $P_{p\text{-max}}$	Minimum preload, $P_{p\text{-min}}$	Allowable limit tensile load, $P_{tl\text{-allow}}$	Allowable ultimate shear load, $P_{su\text{-allow}}$	
											Threads not in shear plane (floating fasteners with grip)	Threads in shear plane (fixed fasteners)
#4	0.112	0.00985	0.00566	0.00660	1056	792	603	816	453	453	936	538
#6	0.138	0.0150	0.00874	0.01014	1622	1217	927	1253	696	696	1421	830
#8	0.164	0.0211	0.01285	0.01473	2360	1770	1349	1823	1012	1012	2010	1221
#10	0.190	0.0284	0.0175	0.0200	3200	2400	1829	2472	1372	1372	2690	1660
1/4	0.250	0.0491	0.0327	0.0404	6460	4850	3691	4990	2769	2769	4660	3110
5/16	0.313	0.0767	0.0527	0.0640	10240	7680	5851	7910	4390	4390	7290	5010
3/8	0.375	0.110	0.0811	0.0951	15200	11400	8686	11742	6520	6520	10490	7700
7/16	0.438	0.150	0.1096	0.1288	20600	15500	11771	15914	8830	8830	14280	10410
1/2	0.500	0.196	0.1493	0.1717	27500	20600	15714	21244	11790	11790	18650	14180



## Design Table 8

A-286 bolts, 160 ksi; retaining device (nut, tapped hole, threaded insert) can fully develop the bolt's ultimate tensile strength											Units: lb, in	
UNRF threads for #4 - #10 (NAS 1351 socket head cap screws), and UNJF threads for 1/4" - 1/2" diameter												
Not separation critical; separation factor of safety times fitting factor = 1.0											Aluminum joint members	
Number of bolts in joint, $n_f = 4$											Temperature stays within 30° F of room temp.	
Maximum initial preload = 75% of allowable ultimate tensile load												
Not lubricated; $\Gamma = 0.35$											Variation for minimum preload, $\Gamma \div \text{sqrt}(n_f) = 0.175$	
Allowable stresses for bolt material:												
$F_{tu} = 160$ ksi											Torque is specified as "above running torque," with a tolerance of +/-5%	
$F_{ty} = 120$ ksi												
$F_{su} = 95$ ksi												
Bolt size	Nominal diameter, $D$	Full-diameter shear area, $A_s$	Minor-diameter area, $A_m$	Tensile stress area, $A_t$	Allowable ultimate tensile load, $P_{tu\text{-allow}}$	Allowable yield tensile load, $P_{ty\text{-allow}}$	Nominal initial preload, $P_{pi\text{-nom}}$	Maximum preload, $P_{p\text{-max}}$	Minimum preload, $P_{p\text{-min}}$	Allowable limit tensile load, $P_{tL\text{-allow}}$	Allowable ultimate shear load, $P_{su\text{-allow}}$	
											Threads not in shear plane (floating fasteners with grip)	Threads in shear plane (fixed fasteners)
#4	0.112	0.00985	0.00566	0.00660	1056	792	559	816	395	395	936	538
#6	0.138	0.0150	0.00874	0.01014	1622	1217	858	1253	607	607	1421	830
#8	0.164	0.0211	0.01285	0.01473	2360	1770	1249	1823	883	883	2010	1221
#10	0.190	0.0284	0.0175	0.0200	3200	2400	1693	2472	1198	1198	2690	1660
1/4	0.250	0.0491	0.0327	0.0404	6460	4850	3418	4990	2418	2418	4660	3110
5/16	0.313	0.0767	0.0527	0.0640	10240	7680	5418	7910	3830	3830	7290	5010
3/8	0.375	0.110	0.0811	0.0951	15200	11400	8042	11742	5690	5690	10490	7700
7/16	0.438	0.150	0.1096	0.1288	20600	15500	10899	15914	7710	7710	14280	10410
1/2	0.500	0.196	0.1493	0.1717	27500	20600	14550	21244	10290	10290	18650	14180

## Summary

Permission is granted by Instar for anyone to freely copy, distribute, and print this material, but only in its unaltered form. This section may be separately copied or printed, but only in its entirety, including this page and with headers and footers intact. Unaltered individual figures and tables and portions of text may be copied or used, but only with text in quotes and with the following statement "Source: Design and Analysis of Bolted Joints (DABJ) course book, Thomas P. Sarafin, Instar Engineering and Consulting, Inc. Reproduced with permission." The date of last revision also should be included in the reference. If you have questions, contact [tom.sarafin@instarengineering.com](mailto:tom.sarafin@instarengineering.com).

## **Summary: Keys to Dependable Joints and Reduced Cost**

- Identify potentially driving requirements, such as any needed alignment for the structural assembly, before you develop a concept for a joint.
- Design to ensure a high preload.
- Make sure the joint will function properly despite uncertainty in preload.
- Keep load paths direct, aiming for high, linear stiffness up to the limit load.
- Design to ensure ultimate failure would be ductile—sufficient plastic deformation to allow loads to redistribute or absorb energy before rupture.
  - If you can't do so, then make more conservative analysis assumptions or use a higher uncertainty factor or fitting factor.
- Match the strength of the nut or insert to that of the bolt.
- Avoid galling by design.
  - Use mating materials of different hardness for fastening hardware.
  - Or use coatings or a lubricant to separate materials.

(continued)

## **Summary: Keys to Dependable Joints and Reduced Cost** (continued)

- Make sure mating threads are dimensionally compatible.
- Account for dimensional tolerances to ensure adequate thread engagement without interference with runout threads or bottoms of blind holes.
- Make sure there is an effective locking feature.
- Design to ensure joints won't slip back and forth in the bolts' clearance holes.
  - Or, when few potential slip cycles are expected, such as for single-mission spaceflight hardware, minimize oversize within practical constraints and reduce the potential number of slip cycles by cleaning the faying surfaces and preloading highly.
  - If the joint can slip, keep threads out of—and away from—the shear plane.
- Before detailing a design or launching into detailed analysis, ...
  - Take time to draw a free-body diagram.
  - Identify potential failure modes.
  - Improve the design if warranted; don't waste time analyzing a bad design!
  - Identify an appropriate method of assessment.

(continued)

## **Summary: Keys to Dependable Joints and Reduced Cost** (continued)

- Make sure strength analysis has an empirical basis.
  - Learn about the tests that were done to establish the allowables or methods to ensure you're comparing apples to apples.
  - Recognize analysis limitations and the need for testing new designs.
- Show by analysis that the joint can withstand design ultimate loads without the benefit of friction.
- Don't over-complicate the analysis.
  - Why calculate load sharing based on bolt stiffness and clamp stiffness for joints that don't require such knowledge? Unnecessary complexity impedes understanding.
  - Preload does not affect ultimate strength for most all-metallic joints.
- Remember that yielding is not always failure and is often beneficial.
  - It's only considered failure if there's a detrimental consequence.
  - When yielding is not detrimental, don't impact a weight-critical design—such as with larger-diameter bolts or reduced preload—in order to show a positive margin on yield.
  - Bolt yielding under applied tensile loading is not detrimental for most joints. (continued)

## **Summary: Keys to Dependable Joints and Reduced Cost** (continued)

- Establish standards and criteria for bolted joints within your organization.
  - Standardize hardware, materials, installation torques and processes, minimum edge distance, minimum wrench clearance, etc.
  - Standardize methods of analysis.
  - Make sure everyone understands the standards or criteria and the reasons for them.
- Specify all engineering requirements related to bolted joints in the engineering drawings and assembly procedures.
- As a program or a company, make sure the technicians assembling critical hardware understand and master the processes and key issues.
  - But, even then, check to ensure your bolts are installed properly.
- Minimize joints in design!
  - Especially in alignment-critical structures.

**Remember to think!**

## Solutions to Class Problems

Permission is granted by Instar for anyone to freely copy, distribute, and print this material, but only in its unaltered form. This section may be separately copied or printed, but only in its entirety, including this page and with headers and footers intact. Unaltered individual figures and tables and portions of text may be copied or used, but only with text in quotes and with the following statement "Source: Design and Analysis of Bolted Joints (DABJ) course book, Thomas P. Sarafin, Instar Engineering and Consulting, Inc. Reproduced with permission." The date of last revision also should be included in the reference. If you have questions, contact [tom.sarafin@instarengineering.com](mailto:tom.sarafin@instarengineering.com).



## Problem 4-2

Following the process on p. 4-24:

Step 1: The applied loads,  $P_1$  and  $P_2$ , are given.

Step 2: Make a quick estimate of bolt loads:

Tension: The 10,400-lb load is centered on the bolt pattern and should be shared equally, whereas the 8040-lb load is aimed approximately at two of the bolts. So the estimated peak bolt tension is

$$P_{tL} = \frac{10,400}{4} + \frac{8040(0.7)}{2} = 2600 + 2800 = 5400 \text{ lb}$$

← sine of 45°

Shear: Based on the assumption that the joint is bearing critical, divide the applied shear by 4 bolts:

$$P_{sL} = \frac{8040(0.7)}{4} = \frac{5600}{4} = 1400 \text{ lb}$$

← cosine of 45°

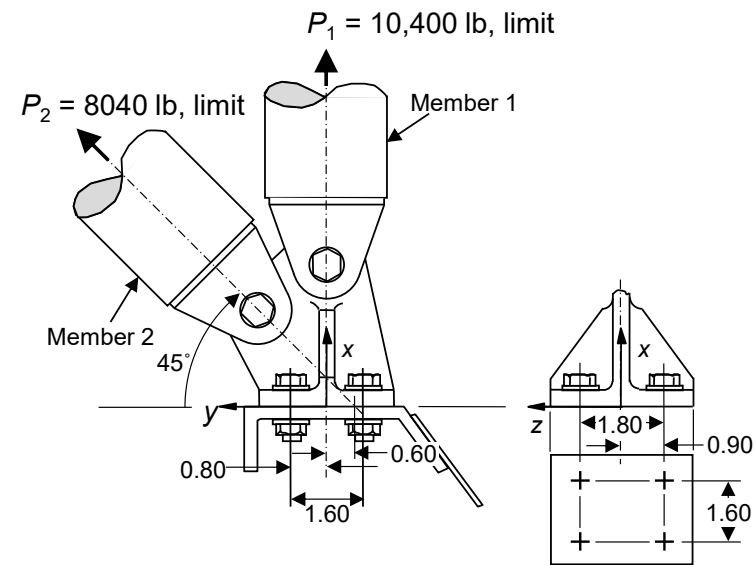

(Continued)

## Problem 4-2 (continued)

Step 3: The centroid has been defined relative to load lines of action.

Step 4: Write equations for transforming loads to the bolt centroid.

$$\text{Tension, } P_x = P_1 + P_2 \sin 45^\circ = P_1 + 0.707P_2$$

$$\text{Shear, } P_y = P_2 \cos 45^\circ = 0.707P_2$$

$$\text{Moment, } M_z = 0.60P_2 \sin 45^\circ = 0.424P_2$$

$$P_z = M_x = M_y = 0$$

Substitute actual given applied loads:

$$\text{Tension, } P_x = 10,400 + 0.707(8040) = 16,100 \text{ lb}$$

$$\text{Shear, } P_y = 0.707(8040) = 5680 \text{ lb}$$

$$\text{Moment, } M_z = 0.424(8040) = 3410 \text{ in-lb}$$

(Continued)

## Problem 4-2 (continued)

Step 5: Develop equations for limit bolt loads in terms of the centroidal loads:

$$\text{Bolt tension, } P_{tL} = 1.1 \left[ \frac{P_x}{4} \pm \frac{M_z}{2(1.60)} \right] = 0.275P_x \pm 0.344M_z$$

$$\text{Bolt shear, } P_{sL} = 1.1 \left[ \frac{P_y}{4} \right] = 0.275P_y$$

1.1 factor to account for potential misalignment

Substitute actual centroidal loads from Step 4:

$$\text{Bolt tension, } P_{tL} = 0.275(16,100) \pm 0.344(3410) = 5600 \text{ lb}$$

$$\text{Bolt shear, } P_{sL} = 0.275(5680) = 1560 \text{ lb}$$

Step 6: Compare with initial quick estimates: 5400 lb and 1400 lb

Looks good

(Continued)

## Problem 4-2 (continued)

Step 7: Combine equations to determine bolt loads in terms of member loads:

$$\text{From Step 4: } P_x = P_1 + 0.707P_2 \quad \text{From Step 5: } P_{tL} = 0.275P_x \pm 0.344M_z$$

$$P_y = 0.707P_2 \quad P_{sL} = 0.275P_y$$

$$M_z = 0.424P_2$$

$$\begin{aligned} \text{Combining: } P_{tL} &= 0.275(P_1 + 0.707P_2) + 0.344(0.424P_2) \\ &= 0.275P_1 + 0.340P_2 \end{aligned}$$

$$P_{sL} = 0.275(0.707P_2) = 0.194P_2$$

Step 8: Substitute given limit applied loads,  $P_1 = 10,400$  lb,  $P_2 = 8040$  lb:

Limit bolt loads:

$$P_{tL} = 0.275(10,400) + 0.340(8040) = 5590 \text{ lb}$$

$$P_{sL} = 0.194(8040) = 1560 \text{ lb}$$

(Same as we got in Step 5 within round-off error, so the Step 7 equations are validated.)

Step 9: Apply factors of safety: We'll leave this step to Sec. 9 of the course.

## Problem 5-1

The lower part failed as shown (combination of tension and shear)

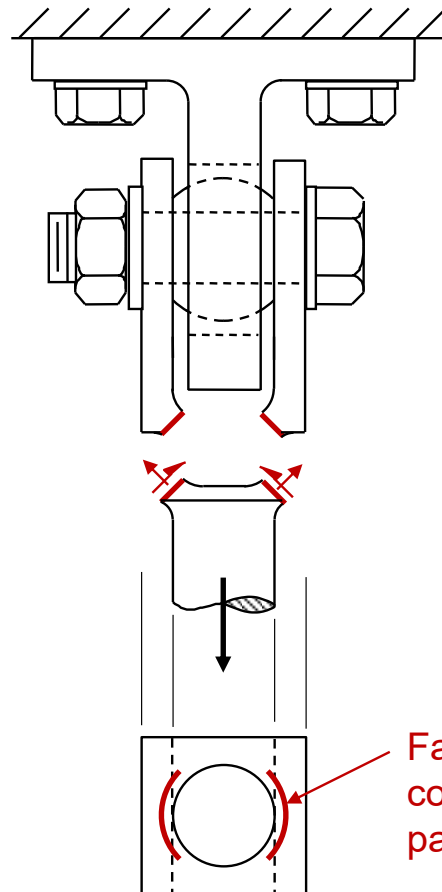

Failure started where stress concentrated, at the stiffest load path, and then propagated.

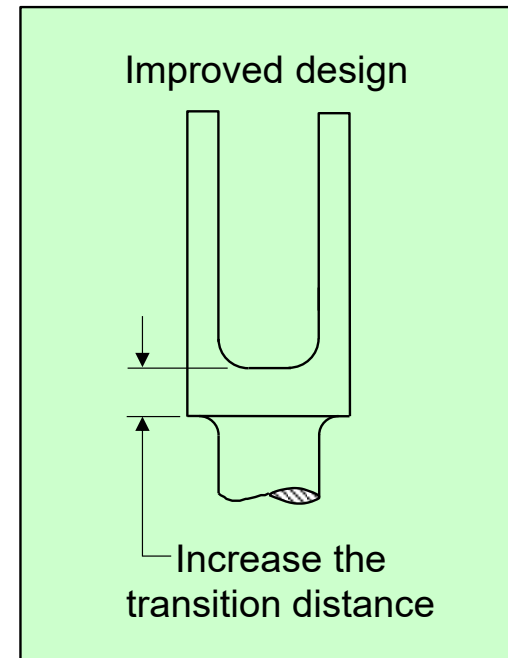

## Problem 5-2

The web of the I-beam failed in shear through the upper line of fasteners. Failure then propagated down.

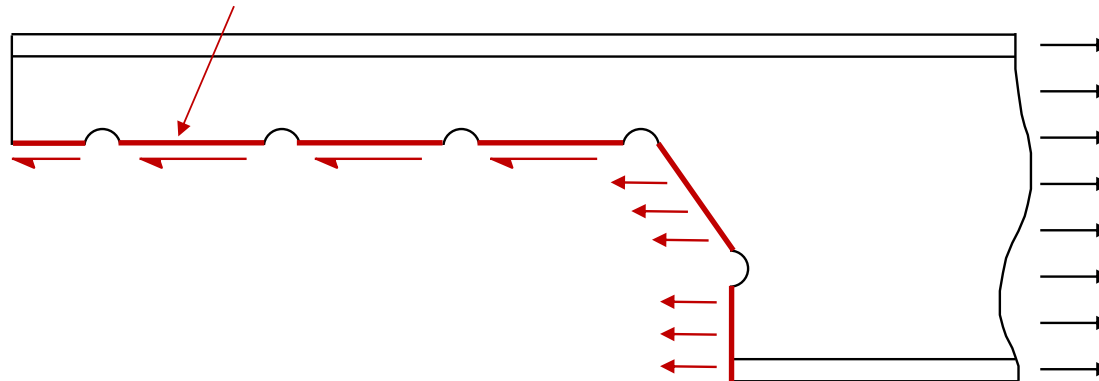

Improved design: All one piece, machined out of bar stock

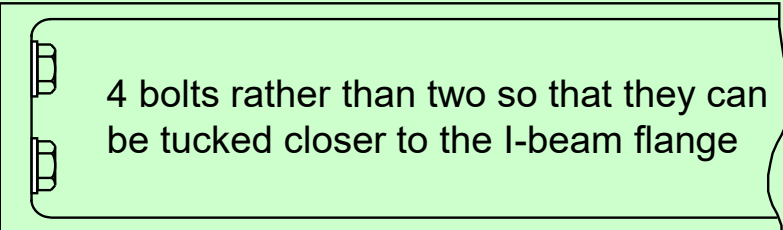

4 bolts rather than two so that they can be tucked closer to the I-beam flange

## Problem 5-3

The ring frame deflects outward radially, causing a large moment through the joint.

Linear-elastic analysis showed  $-0.70$  margin of safety on these Hi-Lok® fasteners.

The fasteners did not fail because they were bearing critical. Plastic deformation allowed other Hi-Loks to carry some of the load.

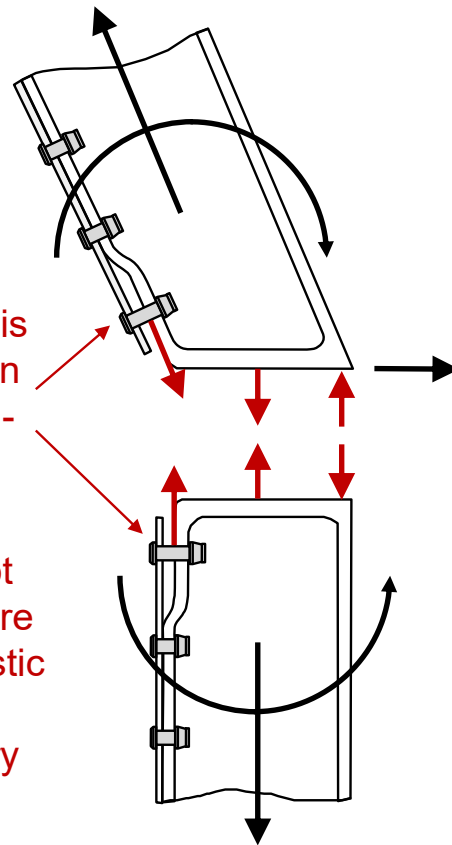

Improved design

Make the ring frame deeper (stiffer in bending) to reduce the joint's bending moment.

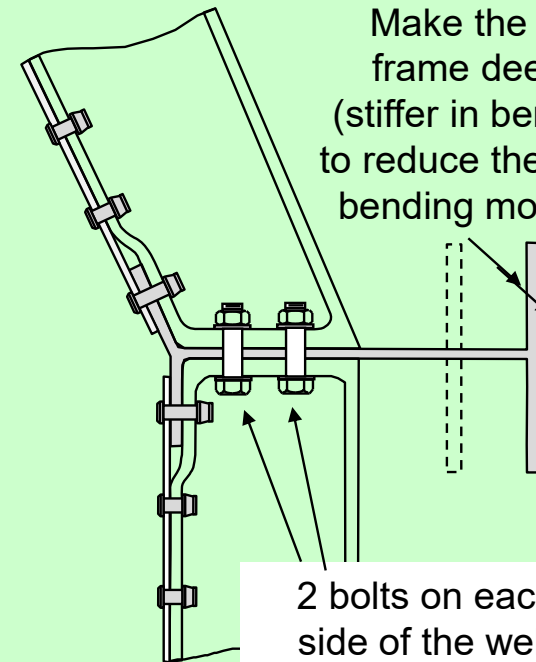

2 bolts on each side of the web rather than one (better load path for moment).

## Problem 9-1: Max/Min Preloads

Given  $n_f = 4$   $T_{s\text{-max}} = 490$  in-lb  
 $D = 0.375$ "  $T_{s\text{-min}} = 450$  in-lb  
 $K_{\text{nom}} = 0.15$  Temperature change,  $\Delta T = \pm 25^\circ$  F

Maximum and minimum effective torques (Eqs. 27 and 28):

$$\begin{aligned} T_{\text{max}} &= T_{s\text{-max}} = 490 \text{ in-lb} && \text{(because torque is specified as} \\ T_{\text{min}} &= T_{s\text{-min}} = 450 \text{ in-lb} && \text{"above running torque")} \end{aligned}$$

Preload uncertainty:  $\Gamma = 0.25$  (given)

## Problem 9-1: Max/Min Preloads (continued)

Maximum initial preload for strength analysis (Eq. 25):

$$P_{pi-max} = \frac{(1+\Gamma)T_{max}}{K_{nom}D} = \frac{(1+0.25)490}{0.15(0.375)} = 10,890 \text{ lb}$$

Minimum initial preload for separation analysis, given that the joint is not separation critical (Eq. 26b):

$$\begin{aligned} P_{pi-min} &= \left(1 - \frac{\Gamma}{\sqrt{n_f}}\right) \frac{T_{min}}{K_{nom}D} \\ &= \left(1 - \frac{0.25}{\sqrt{4}}\right) \left(\frac{450}{0.15(0.375)}\right) = 7000 \text{ lb} \end{aligned}$$

## Problem 9-1: Max/Min Preloads (continued)

Based on Table 8-4 for a 3/8" bolt, assume bolt tensile load increases 7.21 lb for each 1° F increase in temperature.

So the maximum and minimum changes in preload caused by a  $\pm 25^\circ$  temperature change are

$$P_{\Delta T-\max} = P_{\Delta T-\min} = 25(7.21) = 180 \text{ lb}$$

## Problem 9-1: Max/Min Preloads (continued)

Maximum and minimum preloads, accounting for short-term relaxation, creep, and temperature change (Eqs. 1 and 2):

$$P_{p-\max} = P_{pi-\max} + P_{\Delta t-\max} = 10,890 + 180 = 11,070 \text{ lb}$$

For strength analysis

$$P_{p-\min} = 0.95P_{pi-\min} - P_{\Delta t-\min} = 0.95(7000) - 180 = 6470 \text{ lb}$$

For separation analysis

Assuming 5% short-term relaxation

## Problem 9-2: Ultimate Margin of Safety for Bolt Tension

First, let's calculate the load-introduction factor,  $n$ , for this joint:

$$n = \frac{L_{lp}}{L} = 0.5$$

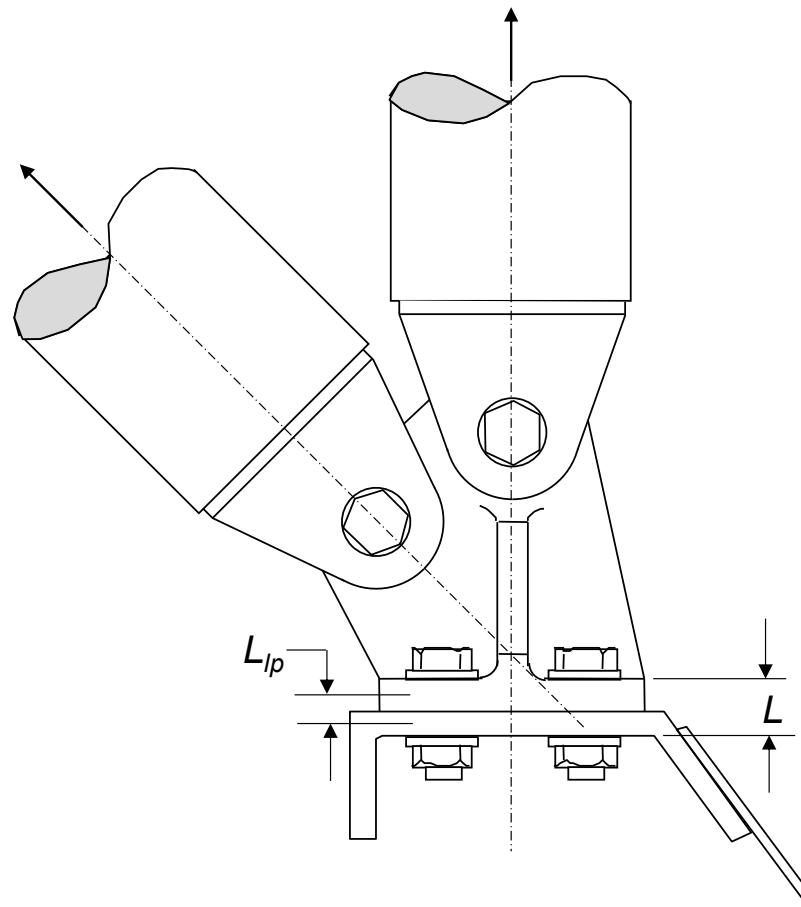

(Continued)

## Problem 9-2 (continued)

Fig. 9-9

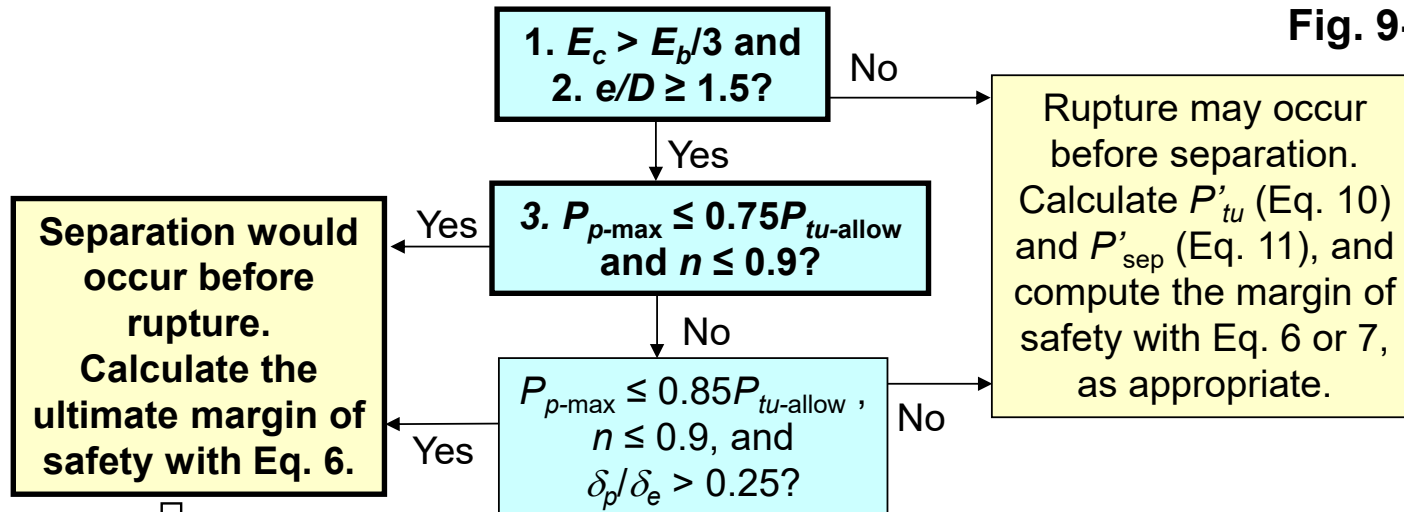

Answers:

1. Yes (steel bolts with aluminum joint members)
2. Yes (given)
3. Yes.  $n = 0.5$  and

$$P_{p\text{-max}} = 11,070 \text{ lb}$$

$$0.75P_{tu\text{-allow}} = 0.75(15,200) = 11,400 \text{ lb}$$

$$(Eq. 6) \quad MS_u = \frac{P_{tu\text{-allow}}}{P_{tu}} - 1$$

$$P_{tu} = FF \cdot FS_u \cdot P_{tL}$$

**Therefore, use Eq. 6 to calculate the ultimate margin of safety.**

(Continued)

## Problem 9-2 (continued)

$$\begin{aligned}MS_u &= \frac{P_{tu-allow}}{P_{tu}} - 1 \\ &= \frac{15,200}{9000} - 1 = +0.69\end{aligned}$$

## Problem 9-3: Separation Margin of Safety

The margin of safety for separation is per Eq. 19:

$$MS_{\text{sep}} = \frac{P_{p\text{-min}}}{P_{\text{sep}}} - 1$$

$$= \frac{6470}{5590} - 1 = +0.16$$

Note that the separation criterion is driving the bolt diameter.

## Problem 9-4: Assessing Bolt Yield

The only potential detriment of bolt yielding is for separation. Alignment is not critical, and friction is already inadequate to prevent joint slip, as we'll see later in this section.

Personally, I would not calculate a yield margin, given the earlier discussion regarding effects on separation and the wide range in preload.

If you're not sure whether bolt yielding is detrimental, first calculate the allowable yield load, then calculate a yield margin with Eq. 15:

$$\text{Per Eq. 18, } P_{ty\text{-allow}} = \left( \frac{F_{ty}}{F_{tu}} \right) P_{tu\text{-allow}} = \left( \frac{120}{160} \right) (15,200) = 11,400 \text{ lb}$$

$$\text{Per Eq. 15, } MS_y = \frac{P_{ty\text{-allow}}}{P_{ty}} - 1 = \frac{11,400}{6990} - 1 = +0.63$$

## Problem 9-5: Bolt Shear and Interaction

### 1. Ultimate margin of safety for shear acting alone:

Threads are not in the shear plane, so the allowable ultimate shear load for a bolt is calculated with Eq. 12:

$$P_{su-allow} = F_{su} \left( \frac{\pi D^2}{4} \right) = 95,000 \left( \frac{\pi (0.375)^2}{4} \right) = 10,490 \text{ lb}$$

The ultimate margin of safety for shear, per Eq. 14, is

$$MS_u = \frac{P_{su-allow}}{P_{su}} - 1 = \frac{10,490}{2510} - 1 = +3.18$$

$P_{su}$  = design ultimate shear load =  $FF \cdot FS_u \cdot P_{sL}$

## Problem 9-5: Shear and Interaction (continued)

### 2. Ultimate margin of safety for interaction

First, assess the applicable NASA-STD-5020B criterion, with the assumption that bolt bending stress is zero because this is a standard single-shear joint with no shims and no gaps across which shear must transfer.

Threads are not in the shear plane, so the criteria in Eqs. 20 and 21 apply. Without bending stress, these criteria are the same.

$$\left(\frac{P_{su}}{P_{su\text{-allow}}}\right)^{2.5} + \left(\frac{P_{tu}}{P_{tu\text{-allow}}}\right)^{1.5} \leq 1$$
$$\left(\frac{2510}{10,490}\right)^{2.5} + \left(\frac{9000}{15,200}\right)^{1.5} = 0.028 + 0.456 = 0.484 \leq 1$$

**Criterion satisfied**

## Problem 9-5: Shear and Interaction (continued)

### 2. Ultimate margin of safety for interaction

Now calculate the margin of safety using Eqs. 9.2 and 9.3:

$$\text{Solve for } a \text{ such that } \left( \frac{aP_{su}}{P_{su\text{-allow}}} \right)^{2.5} + \left( \frac{aP_{tu}}{P_{tu\text{-allow}}} \right)^{1.5} = 1$$
$$\left( \frac{a(2510)}{10,490} \right)^{2.5} + \left( \frac{a(9000)}{15,200} \right)^{1.5} = 1$$

To two decimal places,  $a = 1.59$ , so the margin of safety is ...

$$MS_u = a - 1 = +0.59$$

## Problem 9-6: Assessing Joint Slip at Limit Loads

For the case in which shear is concentrically applied, the margin of safety for joint slip is per Eq. 84:

$$MS_{\text{slip}} = \frac{n_f \mu P_{p-\text{min}}}{FS \cdot (P_{sL-\text{joint}} + \mu P_{tL-\text{joint}})} - 1$$

The total limit tensile load on the joint is

$$P_{tL-\text{joint}} = 10,400 + 8040 \sin(45^\circ) = 16,090 \text{ lb}$$

Two options for how to handle the shear load:

1. Assume the resultant shear is concentrically applied, as it is nominally:

$$P_{sL-\text{joint}} = 8040 \cdot \cos(45^\circ) = 5690 \text{ lb}$$

2. To be more conservative, multiply the resultant shear by the 1.1 factor we used in Class Problem 4.2 to account for potential misalignment:

$$P_{sL-\text{joint}} = 1.1(5690) = 6260 \text{ lb}$$

Given that we're using a conservatively low coefficient of friction and assuming the compressive force is reduced pound-for-pound with the applied tensile load, I choose option 1:

$$P_{sL-\text{joint}} = 5690 \text{ lb}$$

(continued)

## Problem 9-6: Joint Slip at Limit Loads, continued

With  $\mu = 0.1$  coefficient of friction (can't use 0.2 because of the Iridite™),

For slip at limit load ( $FS = 1$ ) →

$$MS_{\text{slip}} = \frac{4(0.1)(6470)}{1.0(5690 + 0.1(16,090))} - 1 = -0.65$$

**Which means we can't count on friction to prevent slip at limit load.**

**This may be okay, depending on the consequence of joint slip.**

**If the expected number of slip cycles is limited, such as for single-mission flight hardware and positional stability is not required for alignment ... tighten the bolt holes to reduce nonlinearity in structural behavior and to reduce potential preload loss associated with cyclic slip.**

**If, on the other hand, these bolts go into threaded inserts, with threads in the shear plane, use shear pins when the margin on joint slip is negative.**

## DABJ Index

Last revised December 2025

- Allowable applied load, 1-20
- Allowable load, 1-20
  - bearing ultimate per bolt, 5-19
  - ultimate shear for a bolt, 5-8; 9-46
  - ultimate tensile for a bolt, 2-13; 5-6
  - yield tensile load for a bolt, 9-34
- Allowable stress, 1-20
  - A-basis, 5-43
  - B-basis, 5-43
  - bearing, 5-19, -20, -21
  - derivation of, 5-3
- Applied load, 1-18
- Assembly
  - guidelines for simplifying, 7-30
- Basic major diameter, 2-5, -15
- Basic minor diameter, 2-5
- Basic pitch diameter, 2-5
- Bearing
  - allowables, 5-19, -20, -21
  - margins of safety, 5-22
  - stress, 5-19
  - ultimate failure, 5-31
  - yield, 5-23, -24
- Bearing-critical joint, 5-32
- Bending, bolt, 3-19; 5-18, -28; 9-48 through -51, -67 through -74
- Bolt (also see “Fastener”)
  - allowable loads
    - shear, ultimate, 5-8; 9-46
    - tensile, ultimate, 5-6
    - tensile, yield, 9-34
  - bending, 3-19; 5-18, -28; 9-48 through -51, -67 through -74
  - design loads, calculation of, 9-5
  - grip, bolt and joint, 7-20
  - length, 7-14
    - selecting, example problem, 7-24
  - loads
    - calculating (applied), Sec. 4
    - calculating total tensile, 8-4, -8
  - margin of safety
    - interaction, 9-52
    - ultimate, shear, 9-46
    - ultimate, tensile, 9-17, -26
    - yield, tensile, bolt 9-42
  - nominal diameter, 2-13, -15
  - reduced-shank, 8-3
  - stiffness, 8-10, -22
  - tensile stress area, 2-13, -14, -15
  - yielding, 9-32 through -42
    - margin of safety, bolt, 9-42
- Brittle failure, 4-2; 5-32, -40; 8-38
  - Avoiding, 5-7; 8-39
- Bushings in sandwich panels, 3-5
- Centroid, bolt pattern, 4-14, -17
- Clamp stiffness, 8-11, -13, -23
  - effective, 8-17
- Class problems:
  - 4-1, calculating bolt loads, 4-11
  - 4-2, compute limit tensile and shear bolt loads, 4-24
  - 9-1, calculating maximum and minimum preloads, 9-11
  - 9-2, ultimate margin of safety for bolt tension, 9-27
  - 9-3, separation margin of safety, 9-31
  - 9-4, assessing bolt yield, 9-43
  - 9-5, ultimate margins of safety for bolt shear and interaction, 9-53
  - 9-6, assessing joint slip, 9-56
- Coefficient of friction per NASA-STD-5020B, 4-7
- Composites, fastening, 5-39 through -43
- Conversion of units, 0-26
- Creep, 1-7; 5-42; 7-38; 9-8
- Criteria matrix, 0-6
- Criteria, typical, 0-5
- DABJ history, 0-11

- Design loads for bolts, calculation of, 9-5
- Design separation load, 1-21
- Design tables, Appendix B
- Design ultimate load (ultimate design load), 1-19
- Design yield load (yield design load), 1-19
- Detrimental yielding, 1-26
- Diameters for threaded fasteners, standard (comparison of inch-based and metric), 0-27
- Dimensional tolerances, accounting for, 4-20, -30, -36; 7-25
- Drill sizes, standard, inch-based, 7-49
- Ductile failure, 4-2, -8, -9; 5-6, -7, -21, -24, -31, -32, -46; 8-31; 9-24
- Ductility, 3-10, 4-10, 5-14
  - for a fastening system, 9-24
- Effective clamp stiffness, 8-17
- Elastic interaction, effect on preload, 7-38
- Elongation, 4-10
- Embedment, 7-38
- End pad
  - bending, 5-10, -11, -14
  - shear failure, 5-10, -11, -13, -14
- Equation numbering, 0-19
- Example problems:
  - 4-a, estimating bolt loads for a joint under tension and shear, 4-15 thru -21
  - 4-b, reworking example problem 4-a with Improved Process, 4-26 thru -29
  - 4-c, accounting for misalignment in example problem 4-b, 4-30 thru -33
  - 4-d, estimating bolt loads for a more complex tension joint, 4-34 thru -42
  - 4-e, same joint as for example problem 4-d, but loaded only my moment  $M_2$ , 4-43 thru -44
  - 4-f, same joint as for example problems 4-d and 4-e: Trying the method used in problem 4-e with both  $P_x$  and  $M_2$  applied, 4-45 thru -47
  - 5-a, allowable load for a shimmed single-shear joint, 5-25 thru -28
  - 5-b, is this a bearing-critical joint or a shear-critical joint?, 5-33
  - 5-c, calculating the design ultimate shear load for a bolt in a joint with eight bolts, 5-35
  - 6-a, deriving an allowable pull-out load, 6-6 thru -8
  - 7-a, matching hardware dimensionally, 7-22, -23
  - 7-b, selecting bolt length, 7-24 thru -29
  - 8-a, estimating  $k_c$  when joint members' geometry does not fully capture the assumed frustums, 8-12
  - 8-b, estimating bolt load for a preloaded joint under applied tensile load, 8-18 thru -21
  - 8-c, estimating  $n\phi$  for a joint with steel or A-286 bolts and aluminum joint members (extreme case), 8-28, -48 thru -59
  - 8-d, could preload reduce the ultimate tensile strength of a joint using the bolt on the preceding page?, 8-32 thru -36
  - 8-e, thermal effects on preload, 8-41, -42
  - 9-a, ultimate margin of safety for tensile loading, 9-20
- Factor of safety, 0-5; 1-19
  - for separation, 1-30
- Failure—see “Brittle failure”, “Ductile failure”, and “Rupture”
- Failure modes
  - for shear joints, 5-18
  - for tension joints, 5-10
  - for threaded fasteners, 5-6, -8, -9
  - identifying (recognizing), 5-5
    - exercise, 5-36, -37, -38
- Fastener (also see “Bolt”), 1-18
  - common types, 3-3, -4
  - fixed, 3-3; 7-51
  - floating, 3-3; 7-51
  - flush-head, 3-20
  - spacing, recommended minimum, 5-29, -41
- Fastening System Control Plan per NASA-STD-5020B, 1-33
- Fatigue, 9-57 thru -61, -75 thru -84
  - life, 1-7
    - effect of high preload on, 8-29
    - verification by similarity to a joint with low likelihood of fatigue failure, 9-58, -59
- Fatigue life requirement per NASA-STD-5020B, 1-27; 9-58
- Faying surface, 3-8
- Finite element modeling of bolted joints, Appendix A
- Fitting factor, 1-19
  - per NASA-STD-5020B, 1-31
  - suggested for shear joints, 5-35
- Fretting, 1-10
- Friction, 1-12; 4-5, -6, -7; 9-54
- Galling
  - avoiding, 7-2, -3, -4
  - definition, 7-2
  - titanium, case history, 7-55

- Grip
  - joint, 7-20
  - bolt, 7-14, -20
- Gussets, 3-8, -13
- Haviland theory, 7-39
- Hi-Lok®, 3-4
- Hole size, fastener,
  - based on true-position tolerance, 7-51
  - recommended for composites, 5-41
  - recommended for metallic parts, 7-52
- Inserts, threaded
  - avoiding shear transfer through, 3-19
  - failure, 5-17; 6-16
  - in sandwich panels, 3-5
  - Heli-Coils®, 5-17; 6-15, -16, -17; 7-8, -9, -46, -53
  - Keenserts®, 5-17; 7-8, -9
  - load rating, 5-16; 7-8
  - pull-out strength, 5-16; 6-16, -17, 7-8
- Interaction of loads on bolt, 9-47 through 9-52
- Jo-Bolt, 3-4
- Joint design (configuration), 3-8 through -19
- Joint diagram, 8-9
  - modified to account for the loading-plane factor, 8-17
- Joint-slip, 1-12, -13
  - analysis, 9-54, -55
- Joint-stiffness factor, 8-4
- Knockdown factor for pull-out strength, suggested, 6-10, -12
- Lead (lead-in) threads, 7-14
- Limit load, 1-18
- Linear stiffness, 3-10
- Liquid thread fillers, 7-42, -44, -45
- Load-introduction factor, 8-4, -15, -16
  - modifying the joint diagram for, 8-17
- Loading-plane factor (see load-introduction factor)
- Lock washers, 7-40
- Lock wire, 7-41
- Locking features, 7-40 through -45
  - adhesive, 7-42, -44, -45
  - liquid thread fillers, 7-42, -44, -45
  - maintaining preload
  - mechanical, 7-41
  - per NASA-STD-5020B, 7-44, -45
  - prevailing-torque, 7-40
  - Spirallock™ threads, 7-43
  - verification of, 7-44, -45
- Lubricant, examples with acceptable outgassing properties, 7-4
- Lubrication during fastener installation, 7-3, -4, -35, -36, -37
  - assumed effect on preload variation, 9-65
- Margin of safety, 1-32; 9-12
  - bearing, 5-22
  - bolt
    - ultimate, interaction, 9-52
    - ultimate, shear, 9-46
    - ultimate, tensile, 9-17, -26
    - yield, tensile, 9-42
  - joint slip, 9-54, -55
  - separation, 9-30
- Materials for fastening hardware, 7-2 thru -5
- Minor diameter for threads, 2-13, -15
- Minor-diameter area, 2-13, -15
- Modulus of elasticity (Young's modulus, elastic modulus), 4-10
- Myths, 0-7 through -9
- NASA-STD-5020, -5020A, and -5020B, 1-14 thru -33; 4-7; 5-8, -8; 7-2, -12, -13, -21, -44, -45; Sec. 9
- Neutral axis for a joint under applied moment, 4-43
- Nominal diameter, bolt, 2-13, -15
- Nut, selecting, 7-6
- Nut factor (torque coefficient), 7-32; 9-9, -66
  - nominal, 7-33
- Nut plates, 7-10
- Pitch, 2-3, -5
- Preload, 1-10, -18
  - benefits of, 1-10; 8-29
  - can preload be too high?, 8-30
  - effect on insert pull-out test, 6-19
  - establishing, 7-32
  - high, effect on fatigue life, 8-29
  - highest practical, 8-32
  - initial, maximum and minimum, 9-8
  - loss of, causes, 7-38, -39

- maintaining, 7-39, -42, -43, -46
- maximum and minimum, calculating, 9-8
- nominal initial, 9-66
- nut factor, 7-33; 9-9, -66
- torque-preload relationship, 7-33
- relaxation, short-term, 7-38; 9-8
- temperature change, effect of, 7-38; 8-40, -43, -44
- uncertainty, accounting for, 9-7, -9, -11
- uncertainty (variation, scatter), 9-9
- Proportional limit, 4-10
- Prying (heel and toe), 3-8, -17; 4-9, -43, -50
- Pull-out load (or strength)
  - definition, 6-3
  - allowable, 6-10
  - allowable, alternate methods, 6-21, -23, -25
- Radius, under-head (head-to-shank), 7-14
- References, list of, 0-20 thru -24
- Root radius, 2-6
- Running (a.k.a. run-in, prevailing, locking) torque, 7-40; 9-10
- Runout threads (transition threads), 7-14
- Rupture
  - before separation, 8-37; 9-15, -17, -18, -26
  - bolt in tension, 5-7
- Sandwich panels, attaching to, 3-5
- Screw threads—see “Threads”
- Seal, 1-7
- Separation (gapping), 1-21
  - analysis suggested by NASA-STD-5020B, 9-30
  - before rupture, 9-16, -17, -19, -26
  - factor of safety, 1-30
  - margin of safety, 9-30
  - nonlinear, 9-28, -29
- Separation requirement per NASA-STD-5020B, 1-28, -29
- Separation-critical joint, 1-21
- Separation load, 1-21; 9-29, -30
  - calculation per linear theory when at maximum preload, 9-16
- Shanking, 7-18
- Shear
  - area for threads based on geometry, 6-4, -5
  - area for threads, design, 6-10, -12, -21, -23, -25
  - clips, 3-16
  - engagement area (see “Shear area for threads”)
  - friction as a load path (also see “Slip analysis”), 4-5; 9-44, -54
    - design for no slip, 7-46
- joints, 3-2
  - design guidelines, 3-8 through 11; 5-29
  - bearing-critical, 4-16; 5-32, -33
  - failure modes for, 5-17
  - shear-critical, 4-16; 5-32
  - slip analysis, 9-54, -55
- load on a bolt, 4-15, -16; 5-7
  - allowable, ultimate, 5-8, -9; 9-46
  - margin of safety for, 9-46
- pins and pinned joints, 3-7
- tear-out, 5-18, -20
- ultimate-strength analysis, 9-46

Shear-critical joint, 4-16; 5-32

Shim, effect on shear strength, 5-25 through -28; 9-50, -67 through -74

Shuttle External Tank, case history, 7-18, -19

Single-shear joint with shim, 5-25 through -28; 9-50, -67 through -74

Skin panels, estimating fastener loads for, 4-51, -52

Slip analysis, 9-54, -55

Spiralock™ threads, 7-43

Spotfacing, 3-8

Stiffness, 1-7

- bolt, 8-10, -22
- clamped material—see “Clamp stiffness”
- linear, 3-10

Strain for uni-axial loading, 4-10

Strength, 1-7

Strength analysis, process for, 5-5

Stress analysis, understanding, 5-3

Stress-corrosion cracking, 8-30

Stress for uni-axial loading, 4-10

Structural life, 1-7

Tapped holes, 3-19, -20; 7-53

Temperature change, effect on preload, 8-40 through -45

Tensile load in bolt—see “Bolt, loads”

Tensile stress area, 2-13, -14, -15

Tension clips, 3-18

Tension joint, 3-2

- failure modes for, 5-10

Tension-shear joint, 3-2

Thread and threads

- cold rolling, 2-6, -7, -9

- cutting, 2-6, -7
- engagement, avoiding problems, 7-20 through -27
- failure, 6-3
- fine vs. coarse, 2-16
- forms, 2-3, -4, -5, -8
  - compatibility of, 2-12
  - metric (M, MJ), 2-4, -5, -6, -8, -11
  - unified (UN, UNR, UNJ), 2-4, -5, -6, -8, -10
- history of, 2-2
- lead, 7-14
- metric(M and MJ), 2-4, -5, -6, -8, -11
- profile, basic, for UN and M threads, 2-5
- pull-out load (or strength), 6-3, -10, -21, -23, -25
- runout (transition), 7-14
- SAE AS8879, 2-6, 6-9
- shear, 6-3
- stripping, 6-3
- tensile stress area, 2-13, -14, -15
- unified (UN, UNR, and UNJ), 2-4, -5, -6, -8, -10
- Threaded fastening system (fastening system), 1-18
- Titanium bolts, 5-7; 7-4, -35; 8-38
- Torque
  - breakaway, 9-10
  - control, 7-32, -33
  - effective, 7-34, -9-10
  - method, 7-32
  - relationship with preload, 7-33
  - running (a.k.a. locking, prevailing, run-in), 7-33
  - specified, 9-10
  - striping, 7-46

- Torque coefficient—see “Nut factor”
- True-position dimensioning for fastener holes, 7-50
- Turn-angle control for fastener installation, 7-32
  
- Units, conversion of, 0-26
- Ultimate design load (design ultimate load), 1-19
- Ultimate failure, 1-7; 5-4
- Ultimate strength, 1-7
  - requirement per NASA-STD-5020B, 1-24
- Ultimate stress, 4-10
  
- Washers
  - benefits, 7-11
  - countersunk, 7-13
  - effect on clamp stiffness, 8-13
  - recommended with high-strength bolts, 7-12, -13
  - use of, 7-11
- Whiskers (e.g., tin whiskers), 7-2
  
- Yield, bolt, 9-32 through -42
- Yield design load (design yield load), 1-20
- Yield failure, 1-7, 5-5
- Yield strength, 1-7
  - requirement per NASA-STD-5020B, 1-26
- Yield stress, tensile, 4-10

## ***Instar's Courses, Taught by Tom Sarafin***

	<u>Page</u>
• SCS—Spacecraft Structures, from Concept to Launch	2
• SDA—Structural Design and Analysis for Aerospace Engineers	4
• DABJ—Design and Analysis of Bolted Joints	6
• STDI—Structural Test Design and Interpretation	8
• VTSS—Vibration Testing of Small Satellites	10
• NFLW—Notching and Force Limiting Workshop	12
• TenP—Ten Principles for Successful Space Programs	13

**We often customize courses to meet client needs**

**We now offer these courses as live, virtual webinars in addition to in-person courses at customer facilities.**

These courses are jointly offered by Instar Engineering and Consulting, Inc., and Applied Technology Institute.

Website: [instarengineering.com](http://instarengineering.com)  
Contact: [tom.sarafin@instarengineering.com](mailto:tom.sarafin@instarengineering.com)

Website: [aticourses.com](http://aticourses.com)  
Contact: [ati@aticourses.com](mailto:ati@aticourses.com)

## SCS—Spacecraft Structures from Concept to Launch

- Presents the structure for a spacecraft as a system
- Objectives: improve your understanding of ...
  - Structural functions, requirements, and environments
  - How structures behave and how they fail
  - How to develop structures that are cost-effective and dependable for space missions
  - Structural verification
- Target audience:
  - Systems engineers
  - Structural and mechanical design engineers
  - Stress analysts
  - Dynamics and loads engineers
  - Anyone else with an engineering degree interested in the subject
- Course length: 3 full days

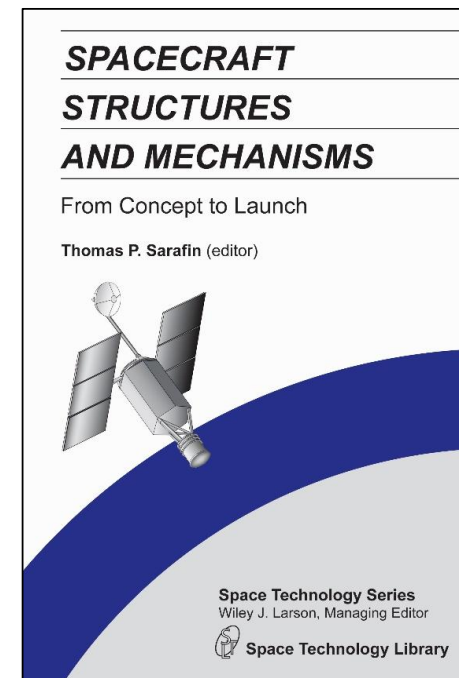

Book upon which the original  
version of this course was based

## SCS Topics

1. Overview of spacecraft structures
2. Launch environments and how structures respond
3. Assessing structural integrity: stress analysis
4. Overview of finite element analysis
5. Configuration development and preliminary structural design
6. Improving the loads-cycle process
7. Verification and quality assurance
8. Final verification and risk assessment

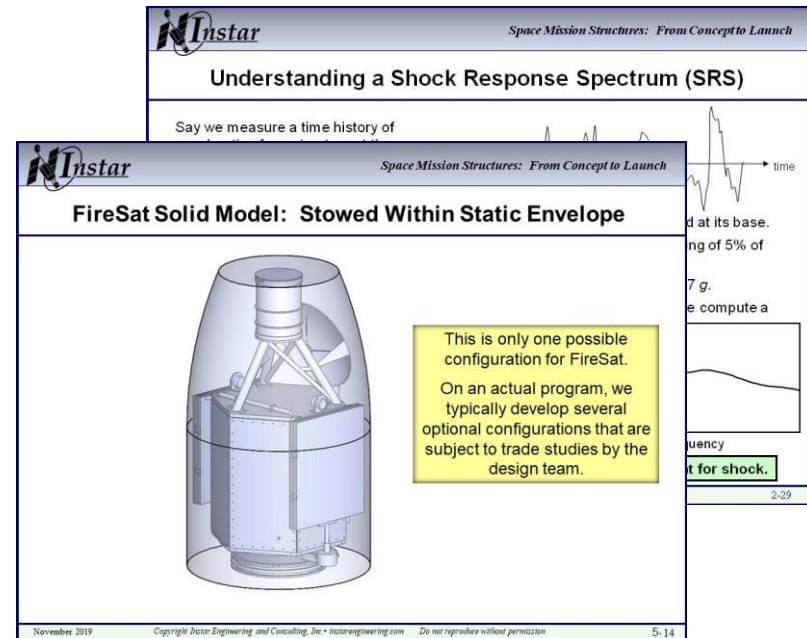

Instar Space Mission Structures: From Concept to Launch

### Understanding a Shock Response Spectrum (SRS)

Say we measure a time history of

Instar Space Mission Structures: From Concept to Launch

### FireSat Solid Model: Stowed Within Static Envelope

This is only one possible configuration for FireSat. On an actual program, we typically develop several optional configurations that are subject to trade studies by the design team.

November 2019 Copyright Instar Engineering and Consulting, Inc. • instarengineering.com Do not reproduce without permission 5-14

“Excellent presentation—a reminder of how much fun engineering can be.”

“This is a great class presented with real-world applications.”

“Many really good examples.”

“Good stuff, and a very clear presentation.”

“I have a much better understanding of structure design issues, especially modeling and its limits. The instructor clearly understands and is effective at communicating this material.”

“Great course!”—former Chief Engineer for USBI

## **SDA—Structural Design and Analysis for Aerospace Engineers**

- This course is a companion or follow-on to Instar's flagship course, SCS—Spacecraft Structures, from Concept to Launch.
  - SCS gives the big picture of spaceflight structures development, with selected details.
  - SDA goes into much more detail on design and analysis of aerospace structures and is not specific to spacecraft. Much of the course applies to aircraft as well.
  - Although we recommend people working in the space industry start with SCS and follow with SDA, SCS is not a prerequisite.
- Target audience:
  - Structural and mechanical design engineers
  - Stress analysts
  - Anyone else with an engineering degree interested in the subject
- Course length: 3 full days

# SDA Topics

1. Structural requirements and design criteria
2. Review of statics and dynamics
3. Mechanics of materials
4. Strength analysis
5. Fatigue of metals
6. Structural design

Structural Design and Analysis for Aerospace Engineers

### Skin-Stringer Example, continued

Step 2. Calculate the panel shear loads needed to generate the stringer loads at the base, recognizing that the stringer loads on the opposite end of the cylinder are zero.

Start at stringer 3 (top): For equilibrium, ...

$$P_3 = 2V_3 ; V_3 = \frac{7.50}{2} = 3.75 \text{ kN}$$

Now move down:

Unwrapped exploded side view of panels and stringers

continued  
 permission 6-70

Structural Design and Analysis for Aerospace Engineers

### Avoid Concentrated Loads on Shells

The key to using any shell or plate efficiently is to introduce loads uniformly rather than concentrated loads.

- Regardless of whether the shell is solid skin, sandwich, isogrid, or orthogrid

Examples:

Monocoque cylinder mated to another monocoque cylinder

Monocoque cylinder mated to a monocoque conical (frustum) shell

Include a bulkhead a deep ring frame to react the radial loads

Or mated to a structure stiff enough to distribute loads

Load from bulkhead or ring frame

Load from frustum

August 2020 Copyright Instar Engineering and Consulting, Inc. • instarengineering.com Do not reproduce without permission 6-55

Structural Design and Analysis for Aerospace Engineers

### Example 4-b, FEA Results

$a = 10''$   
 $b = 2''$   
 $t = 0.1''$   
 $E = 10^6 \text{ psi}$   
 $\nu = 0.33$

Nx Nastran buckling solution:

Buckling stress, $F_{cr}$ :		Displacement plots
2 elements	8 elements	64 elements
11.228 ksi	10.435 ksi	10.064 ksi

vs. 9.38 ksi from the plate buckling equation

Don't rely solely on FEA!

August 2020 Copyright Instar Engineering and Consulting, Inc. • instarengineering.com Do not reproduce without permission 4-66

## DABJ—Design and Analysis of Bolted Joints

***Includes a close look at NASA-STD-5020 (including Revs. A and B),  
“Requirements for Threaded Fastening Systems in Spaceflight Hardware”***

- Objectives:
  - Build an understanding of how bolted joints behave and how they fail
  - Impart effective processes, methods, and standards for design and analysis, drawing on a mix of theory, empirical data, and practical experience
  - Share guidelines, rules of thumb, case histories, and valuable references
- Target audience:
  - Mechanical design engineers
  - Structural analysts
  - Others interested in the subject
- Course length: 3 full days

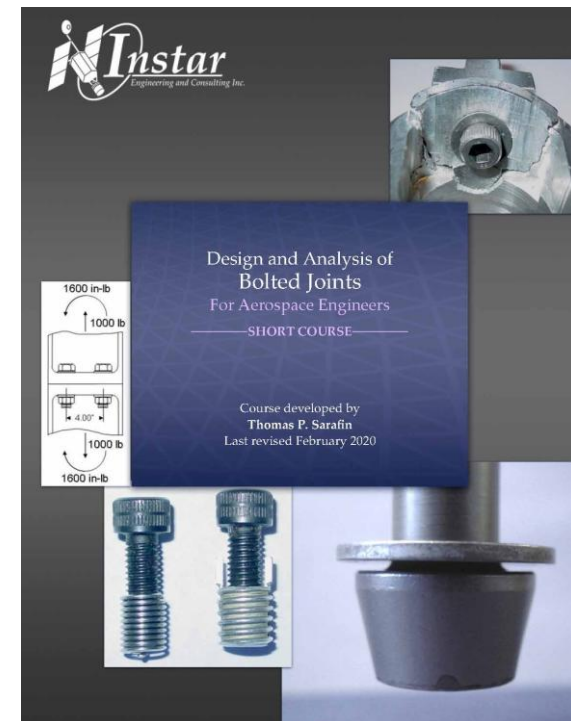

# DABJ Course Topics

1. Overview
2. Screw threads: evolution and important characteristics
3. Developing a concept for the joint
4. Calculating bolt loads when ignoring preload
5. Failure modes and assessment methods
6. Thread stripping and pull-out strength
7. Selecting hardware and detailing the design
8. Mechanics of a preloaded joint under applied tension
9. Fastening system analysis per NASA-STD-5020B
10. Special topics: (a) finite element modeling of bolted joints and (b) deriving design tables for bolt sizing

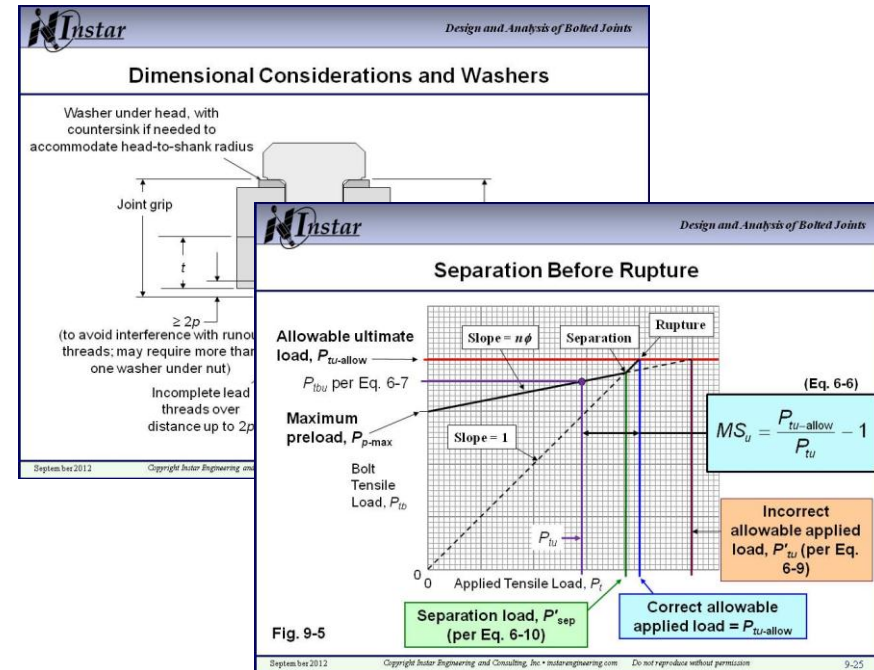

“Well-researched, well-designed course.”  
 “Interaction between instructor and experienced designers (in class) was priceless.”  
 “Best course I have taken.”  
 “Really good course. More people need to take this.”  
 “Great course! Lots of lessons learned. The examples made it that much better.”  
 “Strong emphasis on understanding physical principles vs. blindly applying textbook formulas.”

## STDI—Structural Test Design and Interpretation

- This 3-day course provides a rigorous look at structural testing and its roles in product development and verification for aerospace programs.
- The course starts with a broad view of structural verification throughout product development and the roles of testing, and then covers planning, designing, performing, interpreting, and documenting a test structural requirements and flight environments .
- Objectives are to improve your understanding of how to ...
  - identify and clearly state test objectives
  - design (or recognize) a test that satisfies the identified objectives while minimizing risk
  - establish pass/fail criteria
  - design the instrumentation
  - interpret test data
  - write a good test plan and a good test report
- Target audience: All engineers and managers involved in ensuring that launch vehicles and their payloads are structurally safe and ready to fly
- Course length: 3 full days

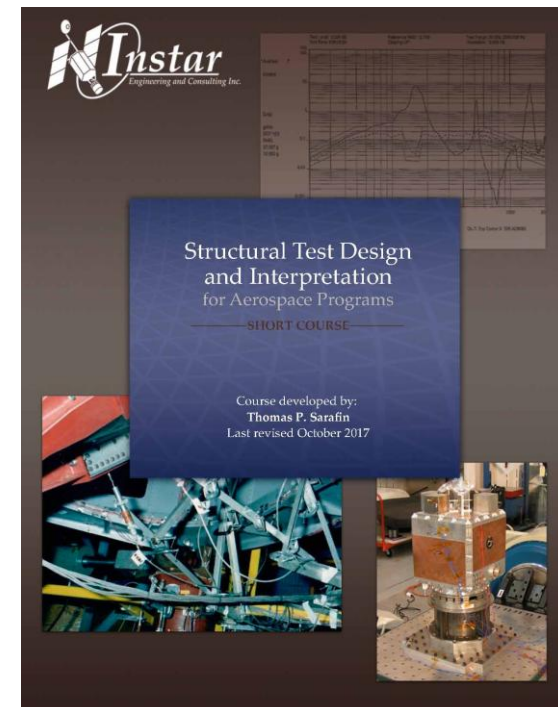

## STDI Course Topics

1. Overview of structural testing
2. Designing and documenting a test
3. Loads testing of small specimens
4. Static loads testing of large assemblies
5. Testing on an electrodynamic shaker
6. Notching and force limiting
7. Overview of other types of structural tests
8. Case history: vibration testing of a large spacecraft telescope

"Good job, Tom. These courses are a big help and give us a lot of great fundamental information."

"Tom Sarafin's courses never disappoint. This class offers a well-balanced blend of fundamentals, examples, and lessons learned that any aerospace engineer involved in structural test design and interpretation would benefit from."

"This is a great course."

**Can be combined with a one-day computer workshop on notching and force limiting (NFLW)**

Structural Test Design and Interpretation

### Computerized Load Control with Hydraulic Jacks

**Advantages**

- Can easily accommodate many load lines, with simultaneous loading
- Near-continuous data acquisition

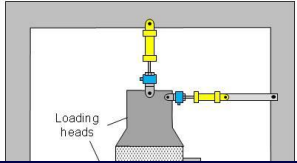

Loading heads

**Disadvantages and Limitations**

- Requires expensive equipment that needs periodic

Structural Test Design and Interpretation

### Example Comparison of Pre- and Post-test Sine-sweep Data

Auxiliary Ch 4  
Fundamental  
Control

Log  
Acceleration  
g (0-pk)

ACF: 1

The test article included a vibration-isolation mounting system with visco-elastic materials.

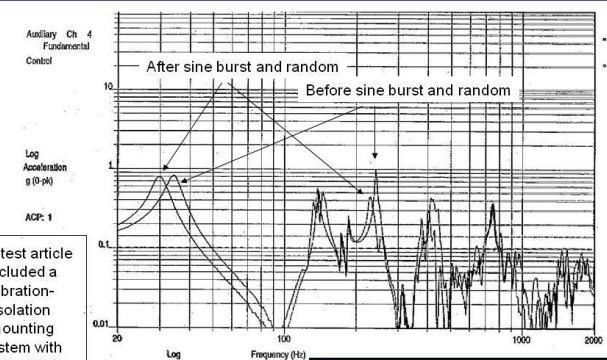

How would you interpret this data?

October 2017
Copyright Instar Engineering and Consulting, Inc • instarengineering.com
Do not reproduce without permission
5-34

## VTSS—Vibration Testing of Small Satellites and NFLW—Notching and Force Limiting Workshop

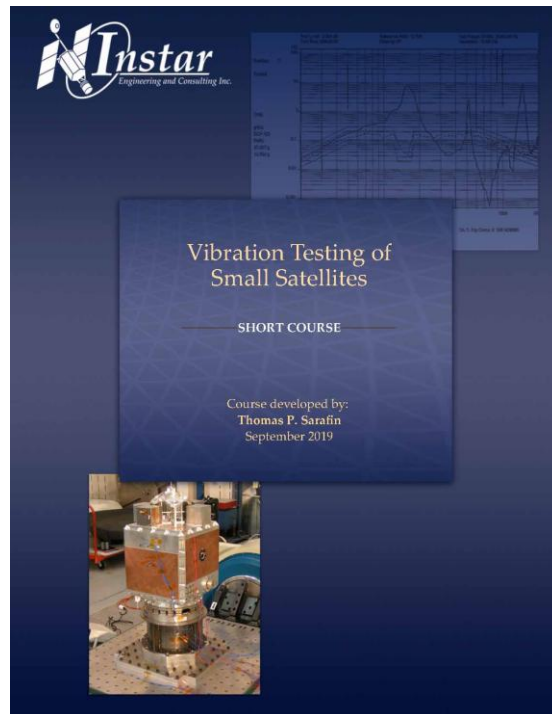

**Can be combined with a one-day computer workshop on notching and force limiting (NFLW)**

- This 2-day course provides a tutorial, practical guidance, examples, and recommendations for testing a small satellite on an electrodynamic shaker. Addressed are sine-burst testing, random vibration testing, and low-level diagnostic sine sweeps. Notching, response limiting, and force limiting are addressed in detail, with examples.
- The course is primarily aimed at satellites in the 50 – 500 lb (23 – 230 kg) range, but most of it also applies to CubeSats. Most of the guidance applies to larger satellites as well if they will be tested on a shaker.
- The objectives are to improve your understanding of how to ...
  - establish an effective vibration test program
  - identify and clearly state test objectives
  - design (or recognize) a test that satisfies the objectives while minimizing risk of an over test
  - establish pass/fail criteria and interpret test data
  - write effective test plans and test reports
- Teacher: Tom Sarafin
- Target audience: All engineers and managers involved in ensuring small spacecraft can withstand launch environments

## VTSS Course Topics

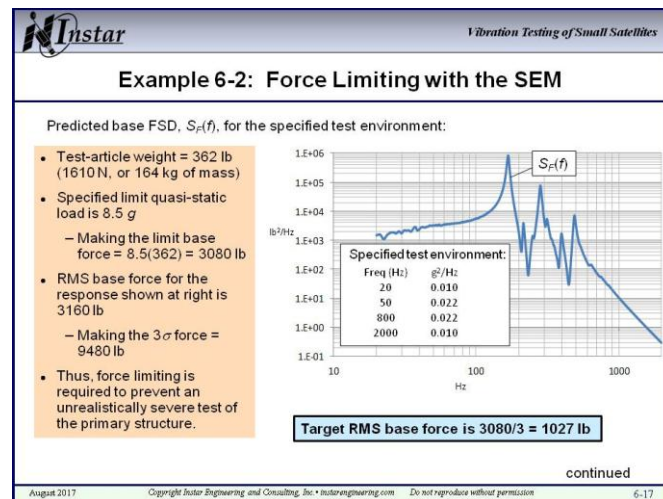

1. Overview
2. Test configuration, fixtures, and instrumentation
3. Low-level sine sweep testing
4. Sine burst testing
5. Random vibration testing
6. Notching and force limiting
7. Test documentation and reviews
8. Designing a SmallSat to Withstand the Vibration Test

“Anyone involved with the mechanical structure of a spacecraft or test engineering of ensuring a spacecraft survives launch should take this course – very well taught!”

“This course was an outstanding look at the way fundamentals of vibration illuminate the execution details of a good vibration test. Tom’s teaching style and many years of experience make for a rich and entertaining course in what is a very complicated topic.”

“Whether you’re a novice engineer with little to no experience in vibration testing or a more experienced engineer with vibration testing history, you’ll walk away from this class feeling you’ve learned a lot.”

## **NFLW—Notching and Force Limiting Workshop**

NFLW is a one-day computer workshop that is available only as an optional follow-on to Instar's STDI (Structural Test Design and Interpretation) or VTSS (Vibration Testing of Small Satellites) course, unless the instructor gives permission otherwise.

- The instructor provides in advance several MicroSoft Excel spreadsheets to be used in class. He then guides the class to complete the first spreadsheet by filling in the applicable equations, as covered in STDI and VTSS. The class then uses that spreadsheet to work an example problem three ways, designing force limits, manual notches, and response limits. The class then similarly works two other examples.
- The objectives of this workshop are for you to “learn by doing”. The goal is for you to be able to design technically justifiable force limits, manual notches, and response limits for future tests.
- Course length: One 6-hour day

## TenP—Ten Principles for Successful Space Programs for Leaders, Managers, and Consultants



1. Invest in knowledge and understanding
2. Adopt the right attitude: Put consistent priority on quality and mission success
3. Instill ownership and responsibility
4. Constantly improve teamwork and communication
5. Follow a sound engineering approach
6. Reduce cost and risk simultaneously with good engineering
7. Keep everything as simple as possible
8. Establish an effective quality system that involves everyone
9. Be willing to accept risks, but only those you and other stakeholders truly understand
10. Make sure you—and everyone else—have enough time, resources, and freedom to follow the above principles

- This course addresses the most challenging problem in the space industry: How do we reduce cost and schedule time while also trying to ensure a successful mission?
- After examining the driving issues in space-system development, the instructor introduces ten principles for successful space programs.
- The course then explores key aspects of leadership, management, and engineering within the framework of those principles.
- Objectives:
  - Provide a fresh focus on quality and mission success
  - Build understanding
  - Spur thought
  - Help your program improve efficiency of its organization and processes—from the top level of management on down to how every engineer or technician approaches his or her job
- Target audience: all leaders, managers, supervisors, systems engineers, and consultants involved in procuring, specifying, designing, producing, or testing space vehicles
- Course length: 2 or 3 full days

# TenP Topics

**Instar** Ten Principles for Successful Space Programs

**Let's Start by Identifying Common Problems in Space Programs**

- Problems with requirements
  - Under specified, over specified, misunderstood, frequently changing
- Problems with designs
  - Difficult to build or test, penalizing to other designs, incompatible materials or fastening hardware, changing after release, mass and power growth
- Process and people problems
  - Decisions based on wrong information, hardware not built to engineering requirements, software not ready on time, test failures that programs can't recover from, not following procedures

**Common elements:**

- Problems that, in hindsight, could have been avoided
- Problems that seem to occur over and over again

*X-33 liquid hydrogen tank test failure, Nov. 1999*

*NOAA-H mishap, Sep. 2003*

1. Why Are Space Missions So Challenging?
2. Finding Solutions: Ten Principles
3. Building a Mission Success Culture and an Effective Team
4. Instilling Ownership and Responsibility in Contractors
5. System Development and Requirements Development (3-day course version includes requirements-writing workshop)
6. Reducing Cost and Risk By Design
7. Verification Planning
8. Managing Risk with a Quality System
9. Responsibly Accepting Risk

**Instar** Ten Principles for Successful Space Programs 1-9

**In the Voyager 2 mission, a cable interference prevented full deployment of the instrument boom**

The mission was degraded because the science boom did not fully deploy and engage its damper. The problem was fixed for Voyager 1, which launched two weeks after Voyager 2 in 1977, based on the test shown below on the test vehicle (spare).

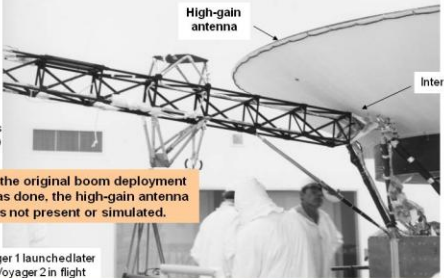

**When the original boom deployment test was done, the high-gain antenna was not present or simulated.**

Note: Voyager 1 launched later but passed Voyager 2 in flight

October 2013 Copyright Instar Engineering and Consulting, Inc. • instarengineering.com Do not reproduce without permission 7-15

“This course does a good job of relaying that no process is going to work unless the people implementing it take pride/ownership in making it work.”

“Great presentation of how the culture of a space program should be developed.”

“All engineers from every field should understand the importance of a quality product as taught by this course.”

“Anyone in the space industry or even thinking of being in the space industry needs this class.”

“My sincere hope is that the fundamental principles here can take hold to move us forward.”